

Uniform deposition of ultrathin polymer films on the surfaces of Al_2O_3 nanoparticles by a plasma treatment

Donglu Shi

Department of Materials Science and Engineering, University of Cincinnati, Cincinnati, Ohio 45221-0012

S. X. Wang

Department of Nuclear Engineering and Radiological Science, University of Michigan, Ann Arbor, Michigan 48109

Wim J. van Ooij

Department of Materials Science and Engineering, University of Cincinnati, Cincinnati, Ohio 45221-0012

L. M. Wang

Department of Nuclear Engineering and Radiological Science, University of Michigan, Ann Arbor, Michigan 48109

Jiangang Zhao and Zhou Yu

Department of Materials Science and Engineering, University of Cincinnati, Cincinnati, Ohio 45221-0012

(Received 13 June 2000; accepted for publication 5 January 2001)

Surface modification of nanoparticles will present great challenges due to their extremely small dimensions, high surface areas, and high surface energies. In this research, we demonstrate the uniform deposition of ultrathin polymer films of 2 nm on the surfaces of alumina nanoparticles. The deposited film can also be tailored to multilayers. Time-of-flight secondary ion mass spectroscopy was used to confirm the pyrrole thin film on the nanoparticle surfaces. Using such a nanocoating, it is possible to alter the intrinsic properties of materials that cannot be achieved by conventional methods and materials. © 2001 American Institute of Physics. [DOI: 10.1063/1.1352700]

The current trend of developing nanophase materials has motivated an increasing need for nanometer-scale structures in a variety of applications.^{1–6} To achieve unique mechanical, physical, chemical, and biomedical properties, one must be able to tailor only the surface structures of a nanoparticle. This requires the deposition of ultrathin films of a few nanometers on the surfaces of nanoparticles. This will ensure that only surface properties, such as surface energy, are modified. Moreover, in the case of multilayer surface coatings, an extremely thin and uniform film on the surface of a nanoparticle is essential.

Surface treatment by plasma polymerization has been used in surface and interface engineering for improving adhesion, hydrophobicity, hydrophilicity, printability, corrosion resistance, selectivity, or for surface etching or cleaning. The main principle of the plasma polymerization technique is that the ionized and excited molecules and radicals created by the electrical field bombard and react with the surface of the substrate. These activated molecules may etch, sputter, or deposit on the substrate surface. As a result, the surface properties of substrates are modified. The plasma technique is a room temperature and environmentally benign process. Due to these characteristics, the plasma technique can be used for surface modification and thin film deposition for almost all substrates, including metal and alloy plates, polymer films, paper, glass, porous materials, and particulate matter.

It has been difficult to deposit thin films on nanoparticles in the plasma polymerization process due to severe aggregation and large surface area per unit mass of the particle.⁷ In the plasma thin film deposition process, it is necessary to expose the surface of the nanoparticles to the plasma. The unexposed regions of the nanoparticles are hardly modified.

The fluidized bed reactor is an ideal tool for gas–particle reactions due to the intensive mass and heat transfer between the two phases, short reaction time, and flat temperature profile.⁸ Therefore, the combination of plasma polymerization and the fluidized bed process represents an innovative approach for low temperature surface modification of nanoparticles.

In this study, ultrathin films of pyrrole have been deposited on the surfaces of alumina nanoparticles using a plasma polymerization treatment. The nanoparticles ranged from 10–150 nm in spherical shapes. High resolution transmission electron microscopy (HRTEM) experiments showed that an extremely thin film of the pyrrole layer (2 nm) was uniformly deposited on the surfaces of the nanoparticles. In particular, the particles of all sizes (10–150 nm) exhibited equally uniform ultrathin films indicating well-dispersed nanoparticles in the fluidized bed during the plasma treatment. Time-of-flight secondary ion mass spectroscopy (TOF-SIMS) experiments confirmed the nanosurface deposition of the pyrrole films on the nanoparticles. This unique nanostructure is developed and will have significant impact in many areas including electronics, functional devices, nanobiomolecular applications, and drug delivery. The deposition mechanism of ultrathin polymer film on nanoparticle surfaces is discussed.

In this experiment, we have selected nanoscale alumina particles ranging from a few to 150 nm. This large distribution of particles is particularly useful for the study of deposition experimental conditions for different sizes. The schematic diagram of the plasma reactor for thin film deposition of nanoparticles is shown in Fig. 1. The vacuum chamber of plasma reactor consists of a Pyrex glass column about 80 cm

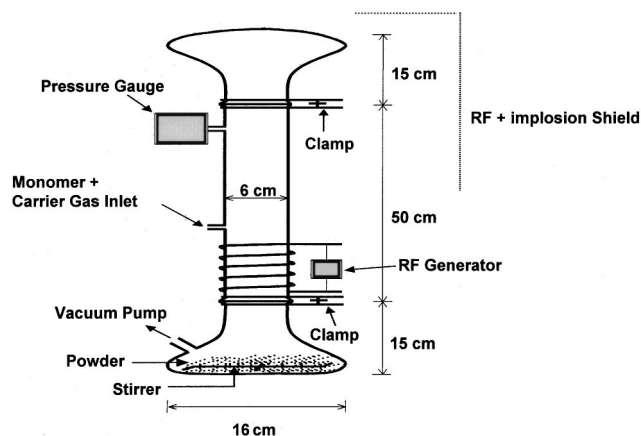

FIG. 1. Schematic diagram of the plasma reactor for thin polymer film coating of the nanoparticles.

in height and 6 cm in internal diameter. The nanoparticles of alumina are vigorously stirred at the bottom of the tube and thus the surface of nanoparticles can be continuously renewed and exposed to the plasma for thin film deposition during the plasma polymerization process. A magnetic bar was used to stir the powders. The gases and monomers were introduced from the gas inlet during the plasma cleaning treatment or plasma polymerization. The system pressure was measured by a pressure gauge. A discharge by rf power of 13.56 MHz was used for the plasma film deposition.

Before the plasma treatment, the basic pressure was pumped down to less than 2 Pa. Then, the plasma gases or monomer vapors were introduced into the reactor chamber. The operating pressure was adjusted by the gas/monomer mass flow rate. Pyrrole was used as monomer for plasma polymerization. During the plasma polymerization process, the input power was 10 W and the system pressure was 25 Pa. The plasma treatment time was 240 min. 40 g per batch of powder was treated.

After the plasma treatment, the nanoparticles of alumina were examined by using transmission electron microscopy (TEM), scanning electron microscopy, x-ray diffraction, and TOFSIMS. The HRTEM experiments were performed on a JEM 4000EX TEM. The TOFSIMS analyses were performed on an ION-TOF Model IV instrument.

The original and nanocoated Al_2O_3 nanoparticles were dispersed onto the carbon film supported by Cu grids for TEM operated at 400 kV. Figure 2(a) shows the bright-field

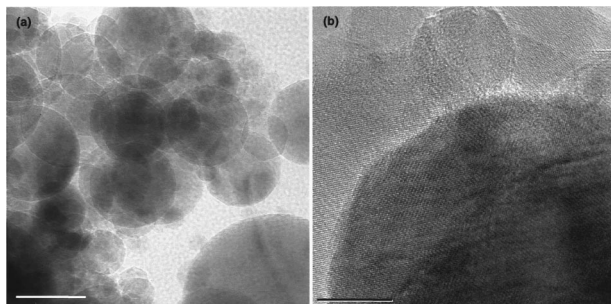

FIG. 2. (a) Bright-field image of the original, uncoated alumina nanoparticles. A particle size distribution ranging from 10–150 nm can be seen (scale bar=50 nm). (b) HRTEM images of the original particles showing crystal lattice and the uncoated nature of the nanoparticle surfaces (scale bar=10 nm).

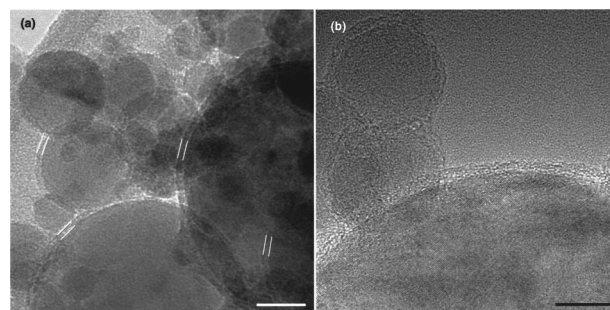

FIG. 3. (a) Bright-field TEM image of the coated alumina nanoparticles (scale bar=20 nm). The coated layers are marked by the double lines. (b) HRTEM image showing the amorphous, pyrrole-coated nanoparticle surfaces (scale bar=10 nm).

TEM image of the original, uncoated alumina nanoparticles. As can be seen in Fig. 2(a), the particle size ranges between 10 and 150 nm. The particles exhibit a spherical shape for all sizes. Figure 2(b) is the high-resolution image of the original nanoparticles. The lattice image clearly shows the naked particle surface of alumina. Figure 3(a) is the bright field image of the coated nanoparticles. An ultrathin film (~ 2 nm) of pyrrole can be clearly seen over nanoparticles of different sizes. The ultrathin film is marked by the double lines in Fig. 3(a). The thickness of ultrathin film is approximately 2 nm all the way surrounding the particle surfaces. Particularly important, although these particles have different diameters, the film remains the same thickness indicating a uniform distribution of active radicals in the plasma chamber. Figure 3(b) is the high-resolution image of a particle with a uniform nanocoating. The ultrathin film is tightly bound to the particles. The film was identified as typical amorphous structure by HRTEM observation over different particles.

To confirm the TEM observations shown in Figs. 2 and 3, TOFSIMS was carried out to study the surface films of the nanoparticles. Figure 4(a) shows part of the TOFSIMS spectra of untreated nanoparticles of alumina. The spectrum of the untreated powder showed an appreciable intensity of magnesium in the surface layers. There were also traces of sulfur, iodine, and organic material. In Fig. 4(b), one can see that the treated alumina has strong pyrrole cluster peaks indicating the surface coating of the nanoparticles and consistent with the HRTEM data presented in Figs. 2 and 3. The treated aluminum oxide shows the characteristic cluster pattern of plasma-polymerized pyrrole [Fig. 4(b)].⁹ The intensity peak at -26 m/z (CN^-) in Fig. 4(b) is typical of all nitrogen-containing functionalities. The intensity peak of Al^+ at $+27$ m/z is *not* the result of an incomplete coverage of the particles by the plasma polymer, but is caused by the intense sputtering of aluminum atoms from the particle surface during the initial phase of the plasma film deposition.¹⁰ Consistent with this view is the absence of magnesium in the spectrum of the treated powder. The aluminum atoms or ions are incorporated in the first five nanometers of the plasma polymer film.

Nanoparticles are known to have extremely high surface areas. As a result of the high surface area, the surface energy can reach the order of 100 kJ/mol for a variety of materials. McHale and co-workers have reported experimental data on the surface energies for alumina nanoparticles.¹¹ They have

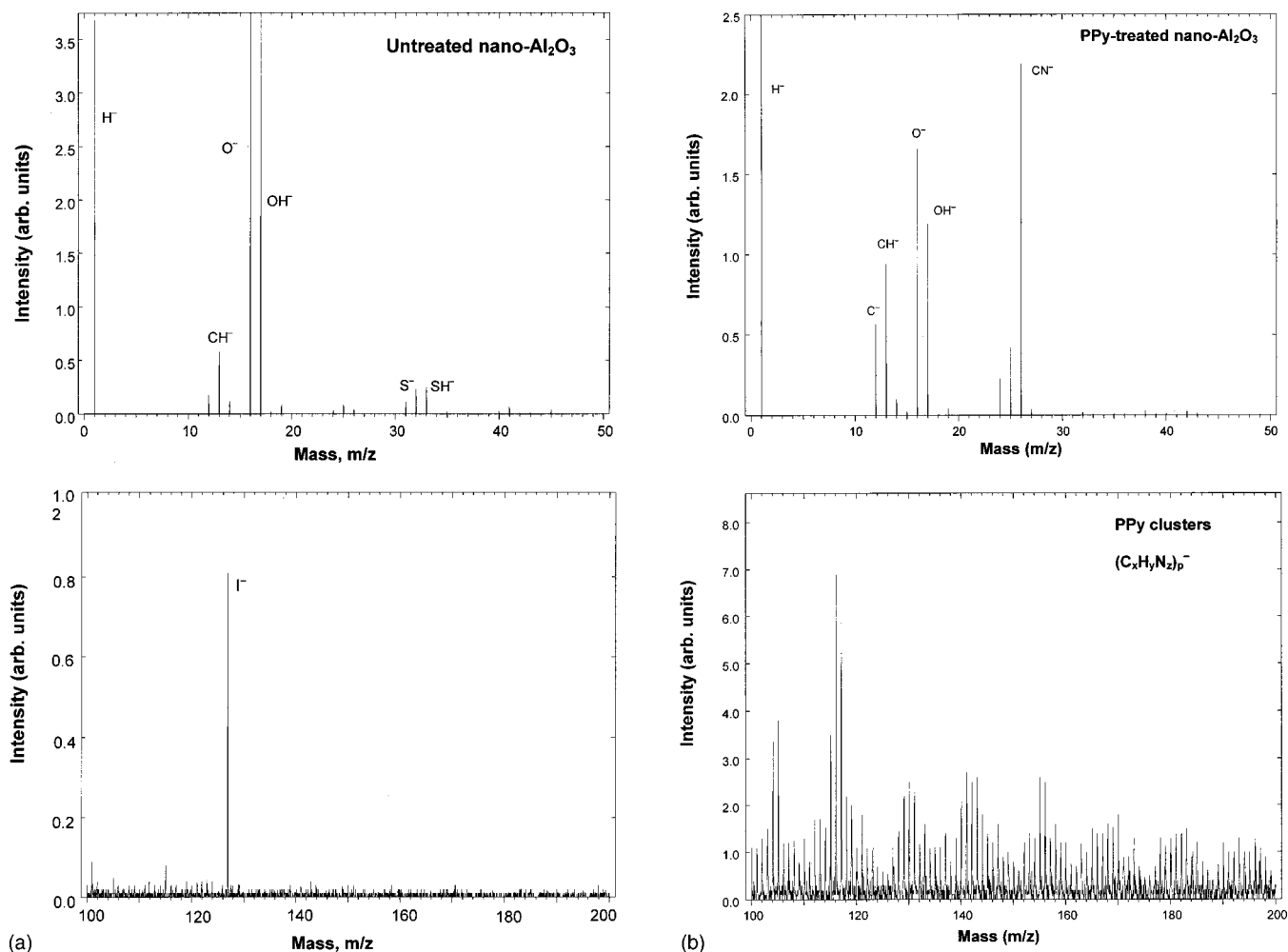

FIG. 4. TOFSIMS spectra of (a) untreated and (b) pyrrole-coated nanoparticles of alumina.

found that γ - Al_2O_3 can maintain surface areas of $150 \text{ m}^2 \text{ g}^{-1}$ at 1073 K. However, α - Al_2O_3 coarsens to values $< 50 \text{ m}^2 \text{ g}^{-1}$ at the same temperature. Based on these findings, they concluded that γ - Al_2O_3 should be energetically stable polymorph as specific surface area exceeds $\sim 125 \text{ m}^2 \text{ g}^{-1}$. During film deposition, the polymer is introduced as a vapor and the collision frequency increases with the gas pressure. Due to the high surface energy of the nanoparticles, condensation of the polymer vapor on the nanoparticles naturally lowers the surface energy by forming an extremely thin film. On a large two-dimensional flat substrate, however, the deposition of the film may cluster severely and form small islands initially, due to its surface tension. A smooth film will require continued deposition at an appreciable thickness. In our deposition process, both energy terms (surface energy of the nanoparticle and the surface tension of the polymer) were balanced by controlling the plasma coating parameters including electron density, temperature, and energy density. The gas pressure must be moderate for a low collision rate on the nanoparticle surfaces. In addition, polymerization should take place relatively fast after the condensation on the particle surfaces. These will ensure a uniform coating on the order of 2 nm for all particle sizes.

In summary, we have deposited an ultrathin film of pyrrole on the surface of alumina nanoparticles by means of a plasma polymerization treatment. The polymer layer is not

only uniform on all particle sizes, but also deposited in an extremely thin thickness of 2 nm. Such ultrathin film deposition characteristics are essential in establishing multilayer nanostructures, tailoring unique physical properties, and pioneering synthesis route.

The TEM analyses were conducted at the Electron Microbeam Analysis Laboratory at the University of Michigan, Ann Arbor, Michigan. This research was supported in part by a Grant from NSF, DMII division, No. DMI-9713715.

¹R. W. Siegel, *Nanostruct. Mater.* **3**, 1 (1993).

²G. C. Hadjipanayis and R. W. Siegel, *Nanophase Materials, Synthesis-Properties-Applications* (Kluwer, Dordrecht, 1994).

³G. M. Whitesides, J. P. Mathias, and C. T. Seto, *Science* **254**, 1312 (1991).

⁴C. D. Stucky and J. E. MacDougall, *Science* **247**, 669 (1990).

⁵H. Gleiter, *Nanostruct. Mater.* **6**, 3 (1995).

⁶*Nanotechnology*, edited by A. T. Wolde (STT Netherlands Study Center for Technology Trends, The Hague, The Netherlands, 1998).

⁷N. Inagaki, S. Tasaka, and K. Ishii, *J. Appl. Polym. Sci.* **48**, 1433 (1993).

⁸C. Bayer, M. Karches, A. Matthews, and P. R. Von Rohr, *Chem. Eng. Technol.* **21**, 427 (1998).

⁹S. Eufinger, W. J. van Ooij, and T. H. Ridgway, *J. Appl. Polym. Sci.* **61**, 1503 (1996).

¹⁰W. J. van Ooij, S. Eufinger, and T. H. Ridgway, *Plasma Polymers* **1**, 231 (1996).

¹¹J. M. McHale, A. Auroux, A. J. Perrotta, and A. Navrotsky, *Science* **277**, 188 (1997).