

**GEOLOGICAL SURVEY OF OHIO**

**J. A. BOWNOCKER, State Geologist**

---

**FOURTH SERIES, BULLETIN 19  
FOR USE IN SCHOOLS**

**GEOLOGY OF CINCINNATI AND  
VICINITY**

By **NEVIN M. FENNEMAN, Ph. D.**  
Professor of Geology, University of Cincinnati

**OHIO DIV. OF GEOLOGICAL SURVEY  
P. O. BOX 650  
SANDUSKY, OHIO**

**OHIO GEOLOGICAL SURVEY  
LAKE ERIE SECTION**

**LIBRARY CARD NO. 6**

**COLUMBUS  
1916**



**HEER PRINTING CO.**  
Columbus, Ohio  
1948

**Bound at the State Bindery**

**GOVERNOR FRANK B. WILLIS:**

**MY DEAR SIR:**—I transmit herewith the manuscript for a Bulletin on the Geology of Cincinnati and vicinity by Professor Nevin M. Fennerman of the University of Cincinnati. This Bulletin was prepared for use in public schools and is therefore comparatively free from technical terms, but scientific accuracy has not been sacrificed for simplicity of statement. In my judgment the Bulletin is an admirable presentation of the subject and I forecast for it extensive use by the people for whom it was prepared.

The field work on which this Bulletin is based was done in the main for the United States Geological Survey, but that organization has kindly permitted the data obtained to be used for this Bulletin and has therefore materially reduced the expense to the State of Ohio.

Respectfully submitted,

**J. A. BOWNOCKER,**  
*State Geologist.*

**April 1, 1916.**

**Blank Page**

# CONTENTS

## INTRODUCTION

	Page.
The aim.....	15
Educational use.....	16
Scope.....	16
Technical Physiography.....	17
Plan.....	17
Field Work.....	18
Acknowledgments.....	18

## CHAPTER I.—DESCRIPTION OF THE AREA

Location and General Relations.....	19
Quadrangles.....	19
Physiographic provinces.....	20
Geologic relations.....	21
Topography.....	23
Technical statement.....	23
Non-technical description.....	23
Plain and plateau distinguished.....	23
Drainage.....	24
Uplands.....	24
Trough of Ohio River.....	24
Dimensions and bluffs.....	24
Gradient of the Ohio.....	26
The valley floor.....	26
Trough of Licking River.....	29
Trough of Little Miami River.....	29
Dimensions and bluffs.....	29
The valley floor.....	30
Trough of Miami River.....	30
Dimensions.....	30
Character of bluffs.....	31
Valley floor.....	31
The Norwood trough.....	32
Mill Creek Valley.....	32
The New Haven trough.....	33
The Union Village trough.....	34
Smaller valleys.....	35

## CHAPTER II.—HOW BED ROCKS ARE MADE

Some General Principles.....	36
Bed rock and mantle rock distinguished.....	36
Igneous and sedimentary rocks.....	36
Source of sediments.....	36
Deposition in the sea.....	37

## CHAPTER II—HOW BED ROCKS ARE MADE—Concluded

	Page.
History of sandstone and conglomerate.....	37
Origin of sand and gravel beds.....	37
Derivation of the quartz.....	37
How grains are formed and carried to the sea.....	37
Experience of sand on the beach.....	38
Sand carried out by the undertow.....	38
Deposits of gravel.....	39
Where the Ohio and Miami derive their sand.....	39
Cementation forming sandstone and conglomerate.....	39
Calcareous cement.....	39
Iron oxide as cement.....	40
Siliceous cement.....	40
History of clay and shale.....	40
Minerals which decompose.....	40
Kaolin or pure clay.....	41
Mud in streams.....	41
Deposition of mud in the sea.....	41
Change of clay to shale.....	42
History of limestone.....	42
Source of lime for marine shells.....	42
Ooze and marl.....	43
Consolidation forming limestone.....	43
How the circumstances during sedimentation are recorded.....	44
Distribution of land and water.....	44
Arrangement of coarse and fine sediments.....	45
What conglomerate and sandstone indicate as to nearness of shore.....	45
What shale indicates as to nearness of shore.....	45
What limestone indicates as to nearness of shore.....	46
Gradation among different kinds of sedimentary rock.....	46
Structural features of sediments interpreted.....	47
Features of sandstone.....	47
Features of shale.....	48
Features of limestone.....	48
Alternation of sediments.....	48
Fossils and their use.....	49
What constitutes a fossil.....	49
Petrifaction.....	50
Scientific value of fossils.....	50
Practical use of fossils.....	50
How sedimentary rocks are grouped.....	51
Various units defined.....	51
Terms denoting divisions of time.....	52
Unconformity.....	52
Geologic maps.....	54

## CHAPTER III.—BED ROCKS OF THIS AREA

General character.....	55
Limestone and shale.....	55
Impurities and gradation.....	55
Structure.....	55
Total thickness.....	56

## CHAPTER III.—BED ROCKS OF THIS AREA—Concluded

	Page.
General Character—Concluded.	56
Division into formations.....	56
Local variation.....	56
General conditions during deposition.....	57
Epicontinental seas.....	57
Evidences of shallow water.....	57
Evidences of low land.....	58
Local rising and sinking.....	58
Table of formations.....	59
Column of rocks.....	59
Cynthiana limestone.....	60
General description.....	60
Fragmental limestone at top.....	60
Break in the record of life.....	61
Dips.....	61
The Eden group.....	61
Utica shale.....	61
How the epoch was inaugurated.....	61
Thickness and geographic relations.....	62
Latonia shale.....	63
Character.....	63
Proportion of limestone.....	63
Thickness and geographic relations.....	64
Topographic relations of outcrop.....	64
Good exposures located.....	64
Falls and rapids.....	65
Soil cover.....	65
The Maysville group.....	65
General character.....	65
Fairview formation.....	66
The basal limestone.....	66
Thickness and geographic relations.....	66
Topographic relations of outcrop.....	67
Good exposures located.....	67
McMillan formation.....	68
Bellevue limestone member.....	68
Corryville shale member.....	69
Mount Auburn shale member.....	69
The Richmond group.....	69
General character.....	69
Formations.....	70

## CHAPTER IV.—PRINCIPLES PERTAINING TO CHANGES NOW IN PROGRESS

Weathering or the breaking down of rock.....	71
Solution and chemical changes.....	71
Passages made by solution.....	71
Caves and limestone sinks.....	72
Other chemical changes.....	73
Mechanical changes.....	74
Frost.....	74
Heat and cold.....	74

**CHAPTER IV.—PRINCIPLES PERTAINING TO CHANGES NOW IN  
PROGRESS—Concluded**

	Page.
Weathering or the breaking down of rock—Concluded	
Mechanical changes—Concluded.	
Plants.....	75
Sapping.....	75
Movements of rock waste.....	75
Creep.....	76
Unconcentrated wash.....	77
Transportation in solution.....	77
Transportation in suspension.....	78
Sand boils.....	78
Contrast of streams.....	78
Transportation on the bottom.....	79
Effect of velocity.....	79
The scouring of channels.....	80
Vertical corrasion.....	80
Lateral corrasion.....	81
Deposition of sediments.....	81
Terminal deposits.....	82
Alluvial fans.....	82
Deltas.....	82
Deposits inside of meander curves.....	83
Deposits made during subsidence of floods.....	83
From suspension.....	83
At bottom of channels.....	83
The making of valleys.....	84
Consequent streams and valleys.....	84
Subsequent streams and valleys.....	84
Origin.....	84
Down-cutting.....	85
Widening.....	85
Headward growth.....	86
Branching.....	87
Cross sections of valleys.....	88
Meandering and flood plains.....	89
Cause.....	89
Change in form of curves.....	90
Change in position of curves.....	90
Planation.....	90
Alluviation.....	92
Flood plain making.....	92
Slopes of flood plains.....	93
Alluvial terraces.....	93
Grading.....	94
Progressive changes in topography.....	96
Beginnings of dissection.....	96
Mature dissection.....	96
Wearing down of hills.....	98
Peneplain in this area.....	98
Renewed uplift.....	99
Cycles.....	99
Rejuvenated streams.....	99
Stream courses of the second cycle.....	100



## CHAPTER V.—THE WORK OF GLACIERS

	Page.
Formation of glaciers.....	101
Valley glaciers and ice caps.....	101
Névé.....	101
Glacier ice.....	101
Movement and crevasses.....	102
The behavior of ice sheets.....	102
Former ice sheets of North America.....	102
Thickness.....	104
Movement over an uneven surface.....	104
Advance and retreat of front.....	104
Lobes.....	105
Load carried by the ice.....	105
Glacial erosion.....	105
Debris on the ice.....	106
Debris in the ice.....	106
Deposits made by the ice.....	106
Ground moraine.....	106
How deposited.....	106
Local character.....	107
Topography of ground moraine.....	108
Terminal moraine.....	108
Ridge at the ice front.....	108
Modes of deposit.....	108
Topography of terminal moraine.....	109
Drift sheets without terminal moraines.....	109
Water-laid drift deposits beyond the glacier.....	110
Outwash plains.....	110
Lake deposits.....	110
Valley trains.....	110

## CHAPTER VI.—HISTORY OF THE PRESENT SURFACE

Preglacial time.....	112
Final rise above the sea.....	112
The making of the peneplain.....	112
Age of the peneplain.....	112
Uplift and erosion.....	112
Preglacial drainage described.....	113
Miami River.....	113
East Fork of Little Miami River.....	114
Licking River.....	114
Ohio River.....	114
Todd's Fork.....	114
Tributary streams.....	115
How this former drainage system is known.....	116
Narrows at Andersons Ferry.....	116
Narrows of the Little Miami.....	117
Direction of tributaries.....	118
Character of the old valleys.....	118
Slope of the bed rock surface.....	118

## CHAPTER VI.—HISTORY OF THE PRESENT SURFACE—Continued

	Page.
The Illinoian glacial stage.....	119
Drainage changes due to glaciation.....	120
Effect of outwash before the glacier arrived.....	120
Changes in Todd's Fork and Little Miami.....	120
The cut-off at Andersons Ferry.....	121
Changes in the Miami.....	122
Other cut-offs by the Ohio.....	123
Changes in Dry Fork.....	123
The older glaciation on the uplands.....	124
Thickness of the till.....	124
Character of the till.....	124
Southern limit of the drift.....	125
Topographic effect.....	125
Inferences as to behavior of the ice sheet.....	126
Thickness of the ice.....	126
Derivation of its load.....	126
The older glaciation in the great valleys.....	127
Topography of the valley drift.....	127
Interstratified materials.....	127
Glacial lobe in Mill Creek Valley.....	128
Behavior inferred from typical sections.....	129
Cumminsville branch of Mill Creek Valley lobe.....	131
Lobe in the Norwood trough.....	131
Lobe in the Little Miami Valley.....	132
Lobe in the Ohio Valley.....	134
Behavior of the ice in the Miami Valley.....	135
The Sangamon Interglacial stage.....	135
Topography left by the Illinoian glacier.....	135
Erosion and soil making.....	136
Relative amounts of erosion on the older and newer drifts.....	136
The Loess stage.....	137
The typical loess.....	137
Character.....	137
Distribution in the United States.....	138
Distribution in this area.....	138
Origin of the loess.....	138
The surface silt elsewhere.....	140
Relation to the loess and drift.....	140
The phase called "white clay.".....	140
Other phases of the surface silt.....	141
Origin of the surface silt.....	141
The Post-loessian stage.....	142
The Wisconsin glacial stage.....	143
Work of the ice.....	143
Early and late Wisconsin stages.....	143
Limits of advance.....	143
Thickness of the drift.....	145
Topography.....	145
Character of the till.....	146
Contact of the two drift sheets.....	146
Behavior of the ice.....	147

## CHAPTER VI.—HISTORY OF THE PRESENT SURFACE—Concluded

The Wisconsin glacial stage—Concluded.	Page.
Work of water in the Wisconsin stage.....	148
Evidences of abundant water.....	148
Outwash deposits of different ages.....	148
The "Forest beds".....	148
Character of the outwashed material.....	149
Miami Valley train.....	150
Little Miami Valley train.....	150
Mill Creek Valley train.....	151
Ohio Valley train.....	153
Silt-filled valleys.....	154
Kames.....	155
Local drainage changes.....	156
Narrows.....	156
Lakes.....	157
The recent epoch.....	159
Changes on the uplands.....	159
Development of drainage.....	159
Revived streams.....	159
Changes in the great valleys.....	160
Work of wind.....	161

## CHAPTER VII.—WATER RESOURCES

Streams.....	163
Navigation.....	163
Ohio River.....	163
Miami River.....	164
Other streams.....	164
Water supply from streams.....	164
Ohio River.....	164
Miami River.....	165
Water power.....	165
Floods.....	166
In the Ohio.....	166
In the Miami.....	166
Causes of floods.....	166
Flood problems.....	167
Increase of percolation.....	167
Reservoirs.....	168
Control of channels.....	169
Underground waters.....	169
General principles.....	169
How water is contained in the ground.....	169
The water table.....	170
Wells.....	172
Water-bearing formations.....	172
Alluvium.....	172
Surface silt and till.....	173
Maysville and Richmond groups.....	174
Eden shales.....	174
Trenton and underlying limestone.....	174
St. Peter sandstone.....	175
Artesian conditions.....	175

## CHAPTER VIII.—MINERAL RESOURCES

	Page.
Building stone.....	177
Quarries in the Fairview formation.....	177
Character of the stone.....	177
Uses.....	178
Road metal.....	178
Clays.....	178
Brick from alluvial clays.....	178
Brick from the surface silt.....	179
Shale brick.....	179
Cupola lining.....	180
Builders' sand and gravel.....	180
From deposits of the Illinoian glacial stage.....	180
From deposits of the Wisconsin glacial stage.....	181
From recent alluvium.....	181
Molders' sand.....	181
Characteristics of molders' sand.....	181
Sand from the loess.....	182
Sand beneath the surface silt.....	182
Sand from the Wisconsin outwash.....	183
Soils.....	183
Soils in general.....	183
Surface and subsoil distinguished.....	183
Constituents of soils.....	183
Functions of subsoil.....	184
Soils classified as to origin.....	184
Soils of this region.....	185
Residual soils.....	186
Surface silt and loess soils.....	186
Soils on the bowlder clay.....	187
Alluvial soils.....	187

## CHAPTER IX.—HABITATION

The Location of Cincinnati.....	189
Order of settlement in the Mississippi Valley.....	189
Importance of navigation of the Mississippi.....	190
Resources advertised by John Cleves Symmes.....	190
Factors controlling the location of Cincinnati.....	191
Character of the site and its influences.....	192
Independent communities.....	192
Local sentiment.....	193
The laying out of private grounds.....	193
City Parks.....	193
Building in the basin.....	193

# LIST OF ILLUSTRATIONS

## FIGURES

	Page.
1. Index map, showing location of the area.....	19
2. Physiographic divisions of a portion of eastern United States.....	21
3. Geologic map of the region surrounding Cincinnati.....	22
4. Sketch map of valleys in vicinity of Cincinnati.....	25
5. Profile of Ohio River from New Palestine to North Bend.....	27
6-12. Cross sections of large valleys.....	28
13. Breaking waves.....	38
14. Diagram showing incoming breakers and outgoing undertow.....	39
15. Diagram showing continental shelf and edge of ocean basin.....	43
16. Modern shell limestone (coquina from Florida).....	44
17. Ripple-marked sandstone.....	47
18. Cross-bedded sandstone.....	47
19. Diagram of large ripple marks on limestone.....	48
20. Diagrams showing unconformity.....	52
21-26. Diagrams to illustrate the nature of geologic maps.....	53
27. Photograph of Jones model of The Earth.....	57
28. Fossiliferous limestone.....	63
29. Diagram showing topographic effects of the several formations outcropping at Cincinnati.....	67
30. Diagram showing passages for ground water in interbedded limestone and shale.....	72
31. Cross sections of valleys.....	85
32a. The deepening, widening and lengthening of valleys.....	86
32b. Later stage of the same.....	87
32c. Still later stage of the same.....	88
33. Diagram illustrating an early stage in the development of meanders.....	89
34. A later stage in the development of meanders.....	89
35. Making a flood plain by planation and lateral accretion of alluvium.....	91
36. Building up of flood plains by material deposited by floods.....	93
37. Making of alluvial terraces during uninterrupted downcutting and meandering.....	94
38. Grading of a stream channel.....	95
39. Diagram illustrating progressive dissection of a plain surface.....	97
40. Plateau in youth, maturity, and old age.....	98
41. Cross section of old valley, and same valley rejuvenated.....	100
42. Longitudinal section of Alpine glacier.....	102
43. Map showing the glaciated area of North America.....	103
44. Glacial erosion on surface of limestone, Kelleys Island, Lake Erie.....	105
45. Diagram showing thinning of glacier and effect on deposition.....	107
46. Kames near Oconomowoc, Wisconsin.....	109
47. Yahtse River, Alaska.....	111
48. Preglacial drainage in the Cincinnati-Hamilton area.....	113
49. Map showing direction of tributaries to the Ohio, east and west of Andersons Ferry.....	117

## LIST OF ILLUSTRATIONS—Concluded

## FIGURES—Concluded

	Page.
50. Diagrammatic representation of terraces in Mill Creek and Little Miami Valleys .....	128
51. Pleistocene formations in southwestern Ohio and southeastern Indiana .....	144
52. Loess on till of Wisconsin age at Reading .....	161
53. Ground water in pores of sandstone .....	170
54. Diagram showing relation of water table to surface slopes .....	171
55. Conditions favorable for artesian wells .....	175
56. Section of an unglaciated hilly country showing gradual transition from solid rock to soil .....	184
57. Section of a glaciated hilly country showing abrupt transition from solid rock to glacial drift .....	185
58. The same, where glacial drift is so thick as to obscure the preglacial valleys .....	185
59. Site of Cincinnati .....	192

## PLATES

	Facing page.
I. A.—Gorge of the Ohio at Andersons Ferry .....	24
B.—Glacial gravel cemented to conglomerate .....	24
II. A.—Waterfall in Eden shale, on West Fork .....	62
B.—Fairview formation near Bellevue Incline, Cincinnati .....	62
III. Fold and thrust fault in Eden shale, West Fork .....	66
IV. A.—Limestone sinks, Covington, Ky., City Park .....	72
B.—Solution grooves in limestone .....	72
V. A.—Revived valleys, Covington, Ky., City Park .....	96
B.—Distorted kame gravels, Camp Hageman .....	96
VI. A.—Interbedded gravel and till, near Coney Island .....	106
B.—Section on Two-Mile Creek, Hamilton .....	106
VII. A.—Glacial terraces west of Spring Grove Cemetery, Cincinnati .....	130
B.—Art Museum and Art School. Built in large part of Cincinnati limestone .....	130
VIII. A.—Erosion topography northwest of New Burlington .....	154
B.—Uneroded kames near Camp Hageman .....	154
IX. Valley of revived stream west of Cumminsville .....	158
X. A.—Flood at Hamilton, March 26, 1913 .....	168
B.—Quarry, Observatory Road, Cincinnati .....	168
XI. A.—Gullied slope south of Bellevue, Ky. ....	176
B.—Badlands west of Spring Grove Cemetery, Cincinnati .....	176
XII. A.—Digging loess for molders' sand, Bellevue, Ky. ....	186
B.—Surface clay near Delhi .....	186

## MAPS

Topographic map .....	In pocket
Physiographic map .....	In pocket

## INTRODUCTION

### *Aim*

This bulletin is intended for the benefit of schools. It is expected at the same time to meet the wants of the general reader in Cincinnati and vicinity who does not know the technique of Geology or Physiography, but is interested to know the plain facts disclosed by those sciences concerning his own home. Scientific researches require technical knowledge and skill in the person making them, but it frequently happens that the results of highly technical researches have a broad human interest and may be stated in plain language. Not only the conclusions but even the evidences may frequently be made plain to intelligent people who would not themselves have been able to assemble and sift the evidence, or who lack the experience necessary to weigh it properly.

These statements are especially true in the domain of Geology where much of the evidence is found in familiar phenomena, the results of processes which are observed daily and not considered mysterious. The chief difficulty to the uninstructed or inexperienced is that the evidences of a geological event are widely scattered in the field and occur in fragmentary form as very homely facts, a bit here and a bit there which the untrained person would not think interesting or significant and never think of putting together. A ledge of very ordinary rock exposed in grading, a gravel bank with no unusual features, a chance exposure of the subsoil, flat fields here and steep hills there, some peculiar feature of a stream which no one would think peculiar unless he had studied the normal habits of streams; it is from such commonplace things as these that the evidences of past history are picked up.

Reconstructing geologic history from such bits of evidence is not unlike the work of a detective. There is even a similarity in the preparation necessary. The successful detective must study the ways of men who commit crime. He must know their ways of thinking and their habits. In other words he must know the *whole process* as well as its *results*. Then from a few chance bits of the result he can tell what the procedure in a given case must have been. Just so, the geologist spends much time studying very familiar processes, the behavior of running water, how it picks up, carries, sorts, and lays down material, how wind does the same things, the decay of rocks, solution, and precipitation, the behavior of glaciers and of waves on the seashore. Then when a complicated story of such activities gets some thousands or

millions of years old it is the geologist's business to gather the bits of evidence remaining and tell not only how it could have happened but how it did happen. To do this with skill and on a large scale is a profession, but the public may understand the story when told, just as a detective story is understood by a layman.

### *Educational Use*

In writing this bulletin the needs of high school students have been kept constantly in mind. It has been the aim to keep both the language and the subject-matter well within the limits of their understanding. Their interests and capacities have been estimated from a considerable knowledge of freshmen in the university. While it cannot be expected that all of them, or even the majority, will study geology, it is greatly to be desired that such as are interested in their surroundings should have some opportunity to study or at least to read about such subjects.

It is not to be expected, however, that the benefits of such a treatise shall be confined to those who are sufficiently advanced to read and comprehend it without help. The writer of a book cannot do in it the work of the classroom, but it is hard to conceive of a teacher of any grade of Geography or Nature Study as knowing what is in this book and then keeping entirely away from these subjects in his daily work. Perhaps this is more true of the general chapters which lend themselves to Nature Study than of the chapters treating specifically of this area.

For the last five years, classes of teachers from Cincinnati and nearby cities have spent their Saturday forenoons at the University or in the field, studying this subject. In the amount of previous information with which they approached the subject, and in the nature of the instruction required, these people have doubtless been good representatives of the intelligent teacher and the intelligent business man. Much that follows was written not only with this class of people in mind but with these very individuals in mind, not so much as they are now since studying the subject, but as they came with very little but the interest.

### *Scope*

The title of this bulletin is given as *Geology*, but it by no means covers that subject fully or symmetrically. Its subject-matter is more largely Physiography than anything else, and the final chapter is neither one of these. It is not believed that the book could be made equally useful by restricting it entirely to Physiography. The unity of the material here brought together is found in the association of earth features assembled by nature in this locality, not in the conventional scope of a science. It is believed also to represent a group of interests which are commonly found together in the same mind. The book is



written in the belief that there is a large class of intelligent people who want to know the explanation of the natural features of the earth's surface about them but who are not concerned with boundary lines between the several sciences.

This is not stated as an apology but as an educational principle. The claim is not made that the best possible selection of material has been made, but it is maintained that any selection for an *educational bulletin* should aim primarily to bring together things which are associated in a common interest at a given stage of intellectual advancement. The criterion by which material is admitted or excluded should not be found in the philosophical definition of a science. The sharper distinctions among the sciences belong to the more technical phases and to a different stage of education.

### *Technical Physiography*

In presenting a physiographic treatise written in language which requires no previous study to understand, it is but just to speak of the advantages of technical knowledge in this line. All the descriptions of the area here treated could be put into a mere fraction of the space if addressed to persons technically educated and commanding the technical vocabulary of the science. Economy demands that such education be made as general as possible. Knowledge of the earth's surface cannot be generally disseminated so long as it is necessary to read thousands upon thousands of pages to get an adequate mental picture of a single country. Very little of the earth's surface is as yet described in brief technical language, and the few descriptions which exist can be read by only a few people. A vast amount of such knowledge is already portrayed in good topographic maps, each map being equivalent in this respect to dozens of pages of description, but few people can interpret the maps. It is surely not too much to say that if the vast literature in which the earth's physical features are described were all in concise technical form, a man previously trained in the general principles could gain in a single year all the knowledge of the earth's surface which he can now acquire in a lifetime.

### *Plan*

It has been deemed best to include in this bulletin several chapters of a general nature, describing the processes at work on the earth's surface. Without such preliminary explanations the chapters pertaining directly to the area would either have been unintelligible to many who should read them, or it would have been necessary to encumber those chapters with an excessive amount of explanatory matter. The principles discussed in the general chapters have been illustrated so far as possible by examples from the area concerned. While nominally

of a general nature, it is believed that these chapters will be quite as effective as the others in turning attention to the study of the immediate locality.

### *Field Work*

The field work which forms the basis of this bulletin was done chiefly under the auspices of the United States Geological Survey. In the summer of 1909 the writer was commissioned to prepare a map of the Pleistocene and recent formations of the two (east and west), Cincinnati quadrangles and to prepare a report on the Pleistocene and Economic Geology of the area. This field work occupied the summers of 1909 and 1911. The map and report thus prepared will form a part of the Cincinnati folio. In the summer of 1913 under similar instructions the writer prepared a similar map of the Hamilton and Mason quadrangles. This map and the accompanying report on the Pleistocene and Economic Geology of that area will be published as a part of the Hamilton-Mason folio.

Aside from the work under the direction of the United States Geological Survey the writer has made various trips and excursions on his own account and in connection with his departmental work in the University of Cincinnati. A limited amount of field work was also done under the auspices of the Geological Survey of Ohio in the summer of 1914.

### *Acknowledgments*

It is due to the Director of the United States Geological Survey and his associates in folio work, to make special acknowledgment of the fact that the three seasons of field work which preceded the preparation of this report were under the auspices and at the expense of the United States Geological Survey.

When this bulletin was begun it was expected that the results of this work would be published by the United States Geological Survey in folio form before the publication of this bulletin. The issue of the folio has, however, been delayed and the Director of the United States Geological Survey has given his permission for the publication of the results in this educational bulletin.

Chapter IV, describing processes at work on the earth's surface, is to a large extent a revision of the corresponding chapter in the writer's similar bulletin on the vicinity of St. Louis. That bulletin was prepared under the auspices of the State of Illinois, and published as Bulletin No. 12 of the Illinois Geological Survey. The principles there discussed were illustrated by examples from the vicinity of St. Louis. In this revision, among other changes, examples have been substituted from the area here described. This acknowledgment is due to the Illinois Geological Survey at whose expense the former report was prepared.

CHAPTER I  
DESCRIPTION OF THE AREA  
LOCATION AND GENERAL RELATIONS

**Quadrangles.**—The area here described lies mainly in southwestern Ohio but extends south a few miles into Kentucky. It is bounded by meridians and parallels, extending from latitude 39° north to latitude

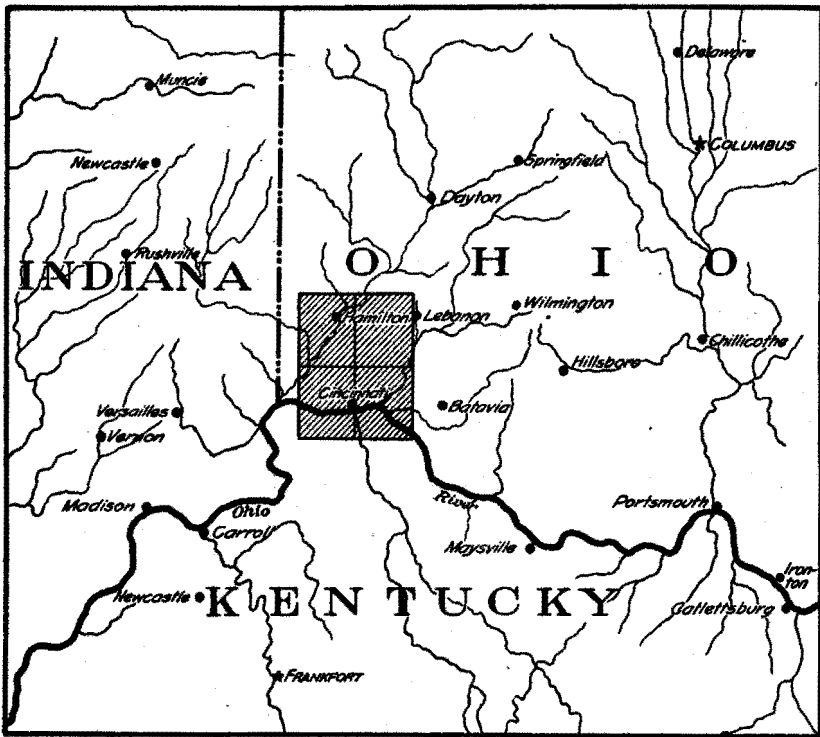

Fig. 1.—Index map, showing location of the area.

39°, 30', and from longitude 84°, 15' west to 84°, 45'. Its length is therefore one-half degree of latitude or about 34½ miles and its width one-half degree of longitude, which is here a little less than 27 miles. The area is about 930 square miles. As defined by the United States Geological Survey it consists of four quadrangles, named respectively,

the Hamilton, the Mason, the East Cincinnati and the West Cincinnati<sup>1</sup>. (See index map, p. 19.) A quadrangle is the unit area for detailed maps and is one-fourth degree each way. It is evident that these quadrangles throughout the United States have substantially the same length north and south (a degree of latitude being about 69 miles), but are broader in the southern part of the country where a degree of latitude is about 60 miles (at New Orleans) and narrower in the northern part where the meridians converge. A degree on the 49th parallel, the Canadian boundary, is 45.47 miles. Quadrangles are therefore not exact rectangles but trapezoids. The area here considered is about one-third of a mile broader on the southern boundary than on the northern.

**Physiographic Provinces.**—This area lies at the foot of a long northwesterly slope leading down from the mountains of Eastern United States to the Central Lowland. A large section of this lowland in Illinois, Indiana, and Ohio is called the Till Plains, for reasons explained in chapters V and VI. The slope which rises eastward toward the Appalachian Mountains is the Allegheny Plateau and is much dissected by stream erosion. Southward from Cincinnati is a large unglaciated area which may be called the Interior Low Plateau.<sup>2</sup> Its northern edge is neither lower nor higher than the Till Plains which it borders, but as seen later (p. 23), the distinction between plain and plateau is not based on elevation but on style of topography. The large natural divisions of the United States are known as physiographic provinces and their subdivisions as sections.

---

<sup>1</sup>In the work of the United States Geological Survey in each quadrangle a topographic map is first made. (Consult maps in pocket). Elevations above sea level are determined throughout the area and at suitable intervals contour lines are drawn by connecting all points of equal altitude. In addition to the forms of the surface, these government contour maps show all streams, roads, towns, and (outside the cities and villages), most of the houses. They are by far the most detailed and accurate maps available. The most common scale is about an inch to the mile. Such maps are now available for about one-half of eastern United States including most of Ohio. In this work Ohio, like some other states, has co-operated with the United States, bearing a share of the expense. Index maps showing the areas thus surveyed may be procured free by addressing a request to *The Director, U. S. Geol. Survey, Washington, D. C.* The several sheets may be purchased at 10 cents each. Enclose money (not stamps) and address *The Director* as above. Usually in the largest villages or city of each quadrangle there is one bookstore or stationery store where the local maps are sold. The Davis L. James bookstore in Cincinnati keeps all the sheets covered by this report.

An exceedingly detailed and accurate contour map on the scale of 13.2 inches to one mile or 400 feet to the inch has been prepared by the Sewer Commission of Cincinnati. It covers an irregular area of more than 100 square miles and is divided into forty-eight sheets which may be purchased at one dollar each from the City Engineer. The entire set costs forty dollars.

<sup>2</sup>Called by C. Willard Hayes in his *Physiography of the Chattanooga District*, the "Interior Lowlands," though in the same paper also "The Interior Lowlands and Highland Rim." See U. S. Geol. Survey XIX, Ann. Rept. Pt. 11. The same region is treated by Powell as a part of the Allegheny Plateau.

Located in terms of these natural divisions this area lies mainly in the Till Plains, but its southern end lies partly within the Interior Low Plateau (see Fig. 2). The boundary between these two is the edge of the glacial drift and is not very sharp at this place. The southern or driftless end of this area is, however, fairly representative of the topography of many thousand square miles in Kentucky and Tennessee. The northern part is less typical of the Till Plains in Ohio and Indiana because of its proximity to important drainage lines where

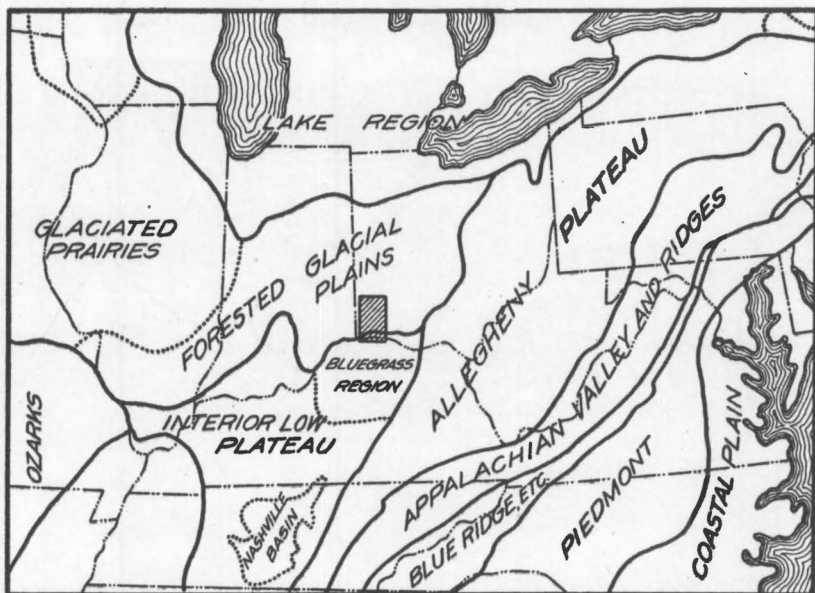

Fig. 2.—Physiographic divisions of a portion of eastern United States. The Till Plains mentioned in the text include the Forested Glacial Plains and the Glaciated Prairies east of the Mississippi. The names of provinces and sections recently adopted by the Association of American Geographers differ in several cases from those here given.

small tributary valleys are numerous and deep. On this account it will be seen to partake more of the plateau character than is the case with the broad interstream plains of central Ohio, Indiana, and Illinois.

**Geologic Relations.**—Located geologically this area is on the northern slope of the Cincinnati uplift, a slight upward bulge of the otherwise horizontal rocks. This upward bulge no longer appears as a rise in the surface, for erosion has planed it all down to a common level. But in doing so, the older and lower rocks were exposed at the surface near the center of the dome. These now appear on the geologic map (Fig. 3), in the Blue Grass Region of Kentucky. Around this center are found successively younger and younger rocks arranged in very ragged and irregular belts.



Fig. 3.—Geologic map of the region surrounding Cincinnati.

## TOPOGRAPHY

*Technical Statement*

The trained geographer will get a satisfactory mental picture of the surface from the following summary statement in technical language: A structure of nearly horizontal thin-bedded limestone and shale, reduced to an almost perfect peneplain, uplifted to about 900 feet above the sea and trenched at least 400 feet by large through-flowing streams (Ohio, Miami, and Little Miami), dissected by tributaries in dendritic fashion almost to maturity near the major valleys but elsewhere young in the cycle following uplift; glaciated (except the southern border), without glacial erosion and with deposition sufficient to obliterate only the smallest valleys; the master streams displaced in parts by the ice, taking new courses which they have since retained. The larger valleys partly filled by till and glacial outwash, which have since been in part removed.<sup>1</sup>

*Non-technical Description*

**Plain and Plateau Distinguished.**—Taken as a whole, the area is part of a widely extended plain. The essential characteristic of a plain is *plainness*, that is, it must be a nearly horizontal surface of small relief. It may be either high (like our western High Plains) or low. The essential characteristic of a plateau is a general level at a considerable altitude, sufficient to admit of deep valley cutting. It may be flat (like our western High Plains) or completely dissected by deep valleys (like most of West Virginia). Hence it follows that a plateau may also be a plain, or the uneroded parts of it may be plains. Again, a widely extended plain like much of Ohio and Indiana may have insufficient altitude to admit of deep valley cutting in the interior, but near its edge, or where trenched by great streams, its margin may be deeply cut by tributaries, that is, dissected in true plateau style. There is therefore no inconsistency in speaking of this area as the edge of a great plain and at the same time speaking of it as a low plateau. No other use of terms could be even approximately consistent with customary usage.

In accordance with the above explanation, this area is part of the

---

<sup>1</sup>By reading this brief summary and carefully inspecting the various maps, the trained geographer will get almost as complete a mental picture of the essential character of the area as from the pages of description which follow, including much of the history given in a later chapter. One of the great aims of physiographic science is to develop and bring into use an exact, concise, technical language which will give to the geographer in a few words all that can be imparted by pages of description. The use of such language (and maps) necessarily involves previous study of physiographic processes and type forms.

southern border of an extensive plain rising 900 feet (locally 50 or 100 feet more or less than that) above the sea; as described below, its edges are eroded in plateau fashion.

**Drainage.**—The area is drained by the Ohio and its tributaries. The master stream crosses in a deep valley near the southern boundary and is joined by the two Miamis from the north and the Licking from the south. The courses of these streams and their tributaries are all shown on the accompanying maps.

The valleys of these large streams, and several similar valleys not now occupied by streams, are 200 to 400 feet deep and one-half mile to 3 miles wide between abrupt bluffs.

### *Uplands*

Near these larger streams and certain large valleys which were former stream courses, the country is very hilly, made so by numerous tributary streams from 10 or more miles in length down to mere ravines and gullies which have cut deep into the bluffs. As a rule there is little or no flat upland between these smaller valleys. There are local exceptions (to be described later) due to the peculiar history of the drainage of the region. Even where no flat upland is found, numerous hills and ridges rise to a uniform height so that when viewed from one of the heights the horizon is nearly flat.

In the broader interstream spaces, back a few miles from the great valleys named, the tributary valleys are fewer and less deep, and there are broad nearly flat uplands such as the ones surrounding Mount Healthy, Mason, and St. Charles (9 miles west of Hamilton).

### *Trough of Ohio River<sup>1</sup>*

**Dimensions and Bluffs.**—The Ohio where it enters the area near New Palestine flows in a trench or trough 400 feet deep and less than

<sup>1</sup>There is no word in general use to describe that portion of a river's valley which is bounded by its bluffs. The word *valley* is the most convenient term after the sense in which it is to be used is once made clear, but it is used in other senses beside the one here specified. Frequently it refers to the entire drainage basin as in the common use of "Mississippi Valley" and "Ohio Valley," generally also "Miami Valley." The valley between bluffs, where the latter are abrupt, is often referred to as a *gorge*, but this word would better be reserved for narrow cuts which are practically without flood plains. The word *trough* was suggested by the writer in discussing the Mississippi<sup>1</sup>. (See Illinois Geol. Survey Bull. 12, page 13.) Probably the word *trench* would correspond better in most minds to the conception of a deep cut with a nearly flat bottom. The word *entrenched* is already in general use to describe such a cut in a special case (entrenched meanders). The word *trench* has been used descriptively in exactly the sense here intended by a number of good writers. There is little choice between the words *trench* and *trough*. Sometimes the words "immediate valley" are used in the narrower sense to distinguish such a trough from the entire drainage basin.



PLATE I.



A.—Gorge of the Ohio at Andersons Ferry as seen from the hill east of Ludlow, Ky.  
The lagoon is artificial. (See p. 26.)



B.—Gravel in the outwash of the Wisconsin glacial stage, cemented to conglomerate by carbonate of lime. Note the huge mass at the right. Langdon's gravel pit, Linwood.

a mile wide between its abrupt though eroded bluffs. The trough continues with approximately these dimensions to the mouth of the Little Miami where the flood plain of the former stream merges with that of the latter in the extensive "Turkey Bottoms" so frequently mentioned in the history of the first settlement of Cincinnati.

Westward from Turkey Bottoms and opposite Dayton, Ky., the bluffs approach each other within three-fourths of a mile or a little

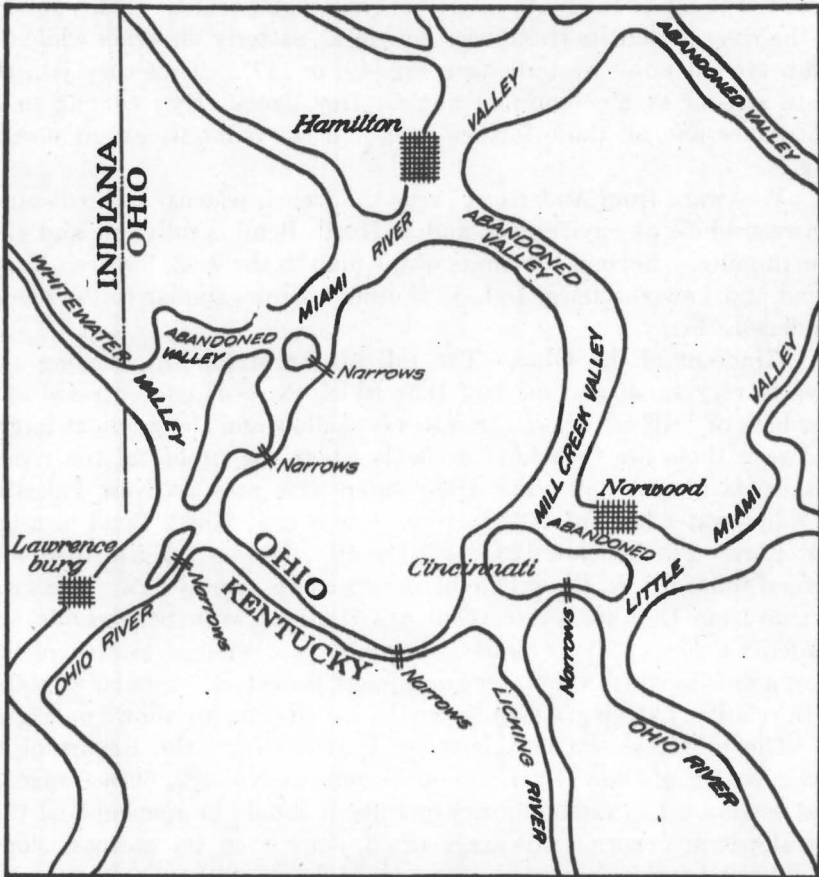

Fig. 4.—Sketch map of valleys in the vicinity of Cincinnati. Compare Fig. 59, p. 192.

more. Beyond that the trough widens into a great rectangular flat which contains the cities of Covington and Newport, Ky., and the business section of Cincinnati. This remarkable expansion is about 4 miles long from northwest to southeast and more than two miles wide. The Ohio crosses it from its eastern to its western corner. Licking River enters at the southern corner and Mill Creek at the northern. This pan-shaped depression may be called the Cincinnati basin (Fig. 4).

Westward from the Cincinnati basin, the trench again narrows, this time to one-half mile at a point just east of Andersons Ferry (Pl. IA,

opp. p. 24, also Fig. 59, p. 192). The depth of the valley, which elsewhere differs little from 400 feet, is here fully 450 feet. This locality is also remarkable for the flat undissected character of the uplands immediately behind the bluffs. The south bluff for a distance of three miles east of Andersons Ferry is almost free from gullies. Both north and south of the river the divide separating the waters which flow directly to the Ohio from those flowing in the opposite direction is very close to the top of the bluff. Another remarkable feature of this portion of the river is that its tributaries flow in an easterly direction while the main stream flows westerly (see Fig. 49, p. 117). Thus they join the main stream at an abnormal angle. Dry Creek, Ky., coming in at Constance and all those farther west join the main stream at normal angles.

Westward from Andersons Ferry the trench widens. The distance between bluffs at Saylor Park and at North Bend is fully one and one-fourth miles. Beyond the limits of the map to the west, between North Bend and Lawrenceburg, Ind., is another narrows similar to the one at Andersons Ferry.

**Gradient of the Ohio.**—The fall of the stream in crossing this area is very small and most of that which exists is concentrated at a few bars or "riffles" where the water is shallow and the gradient larger. Between these are "reaches" or pools where the profile of the river's surface is almost flat. The Ohio enters this area at New Palestine at a low water level of 442½ feet and leaves it at North Bend at a low water level a little below 429 feet. For 10 miles above North Bend and several miles below, the profile of the stream is almost flat. The same is true from Dayton, Ky., to Cullom's Riffle between Sedamsville and Andersons Ferry. This "riffle" or ripple is a shallow stretch of less than a mile in which the water falls almost three feet. Similar stretches with relatively steep gradient, generally called *bars*, are shown on Figure 5. The profile shown in this figure is taken from the Report of an Examination of Ohio River, House Document No. 492, 60th Congress, first session. In examining such profiles it should be remembered that the slopes are enormously exaggerated, since even the steepest slopes would not be discernible on a diagram if drawn without exaggeration.

**The Valley Floor.**—Through most of its length and breadth the floor of this trough is the flood plain, most of whose surface is between 460 and 500 feet above the sea. Fragments of a former floor at 540 feet, more or less, form important terraces. Most of the Cincinnati basin has its floor at this level and the same level extends up the river to Dayton, Ky., and down to Ludlow, also up the Licking. Small fragments of this former level are found at California and where Four-mile Creek, Ky., emerges from the bluffs. Larger fragments are found at Saylor Park and on the Kentucky side opposite Delhi and North Bend. Everywhere this terrace consists of sand and gravel. This

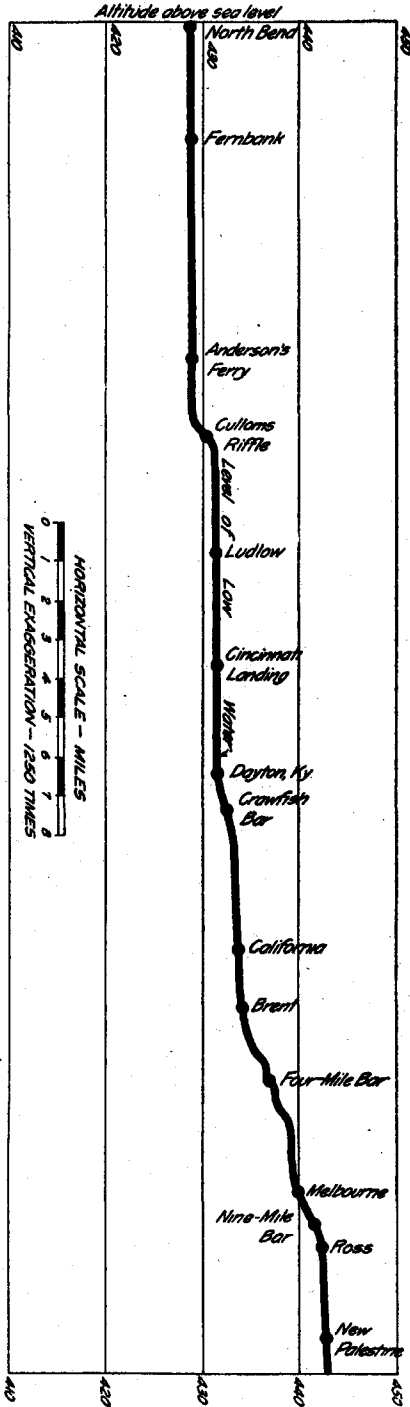

Fig. 5.—Profile of Ohio River from New Palestine to North Bend.

is being dug for commercial purposes at various places, notably at Sedamsville, Ludlow, Ky., and Bellevue, Ky., and in a small way at California.

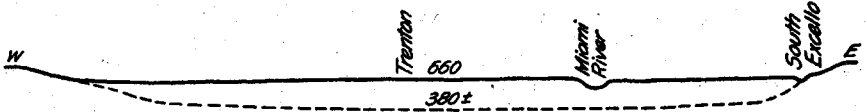

FIG. 6. Cross section of Miami Valley south of Middletown

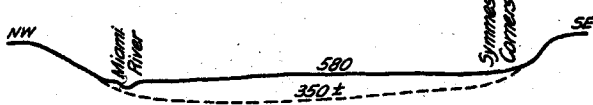

FIG. 7. Cross section of Miami Valley south of Hamilton

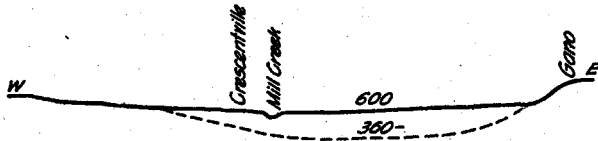

FIG. 8. Cross section of Mill Creek Valley north of Sharonville

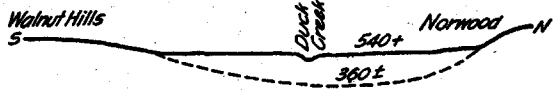

FIG. 9. Cross section of Norwood trough



FIG. 10. Cross section of Little Miami Valley at Milford

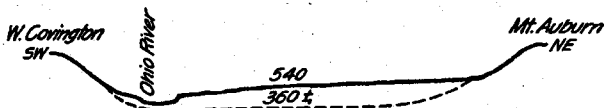

FIG. 11. Cross section of Cincinnati Basin

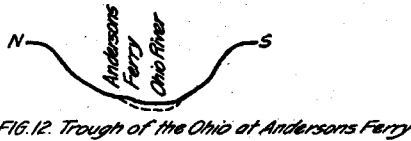

FIG. 12. Trough of the Ohio at Andersons Ferry



Figs. 6-12.—Cross sections of large valleys; vertical scale three times the horizontal. The broken line beneath shows the approximate level of the rock floor in each case. Data are insufficient to draw this line accurately.

Another kind of terrace is exemplified at California, making the level on which the largest reservoirs of the Cincinnati waterworks are constructed, a little less than 600 feet above the sea. The terrace at that place is about one-half mile wide and it extends with diminishing clearness for two miles north and two miles east to Fivemile Creek. The material of this terrace is in part sand and gravel, but in part also unassorted clay and stones, the boulder clay described on page 107. Some large boulders were removed in constructing the reservoirs.

#### *Trough of Licking River*

The immediate valley of the Licking is very similar to that of the Ohio and nowhere in this area is it narrower than that of the Ohio at Andersons Ferry. South of the mouth of Banklick Creek its width is one-half mile or more and its depth not quite 400 feet below the uplands. North of Banklick Creek is a large triangular expansion (maximum dimension, two miles), similar to the Cincinnati basin and connected with the latter by a passage one mile wide. In this basin lies Latonia or Milldale, now a part of Covington.

The floor of the Milldale basin is an extension of the terrace which forms the bottom of the Cincinnati basin. There are also large strips and patches of the same level bordering the Licking, though outside the Milldale basin the larger part of the valley floor is at the lower level of the present flood plain. The materials of the terrace on the Licking is in very small part sand and gravel. It is mainly silt.

#### *Trough of the Little Miami*

**Dimensions and Bluffs.**—The immediate valley of the Little Miami is much broader than that of the Ohio (see Fig. 59, p. 192). Near its mouth, it has also the same depth, though the depth diminishes up stream, the level of the uplands remaining about constant and that of the river rising 130 feet between its mouth and Loveland, a distance of only 16 miles in a direct line, but probably about 25 miles by the river. The fall in this portion of the stream is therefore about five feet to the mile.

Between the mouth of the Little Miami and Milford the width of the valley floor ranges from one and one-fourth to one and three-fourths miles, and is therefore much greater than that of the Ohio. While the bluffs are everywhere bold, they are much more dissected by valleys than those of the Ohio and correspondingly lacking in steepness. The uplands at full height rarely approach so close to the valley as is commonly the case along the Ohio. The significance of these features is explained in the history of the drainage (page 120).

South of Milford is the junction of the East Fork of the Little

Miami with the main stream. The broad valley and flood plain below the junction find their upstream continuation along the East Fork and not along the main stream coming from the north.

Ascending the main stream to the north from Milford, the valley soon becomes narrow, less than one-half mile, but it widens and narrows somewhat irregularly, being almost a mile wide just north of Camp Dennison, a little more than half a mile at Loveland, and narrowing to a sharp gorge just south of Foster. North of that it widens a little, but not much until it approaches South Lebanon beyond the limits of this area. In this stretch north of Milford the upland (not quite so high as farther south along the Ohio) approaches at many places very close to the stream. The bluffs are more even and less gullied than those south of Milford, indicating that they are decidedly younger.

**The Valley Floor.**—South of Terrace Park and in the valley of East Fork most of the valley floor is flood plain, liable to overflow. Its level on the Turkey Bottoms is 460 to 500 feet; near Milford it is 500 to 540 feet; at Loveland its upper limit is near 600 feet. Other large areas in the floor of this valley consist of terrace; remnants of a former floor, continuous with that mentioned in the Ohio trough at or above the 540 foot level. The level of these fragments rises towards the north. At Redbank and south of Newtown it is about 530 feet. The fine broad terraces at Terrace Park, Milford, Camp Dennison and Miamiville are above 560 feet. Near Symmes and Branch Hill the level is at least 580 feet, and at Loveland above 600 feet. All these terraces are of gravel, very coarse and heavy in the narrower part of the valley above Milford. A small patch of similar terrace on the north side of the East Fork consists of silt like those along Licking River, Kentucky.

Higher terraces of bowlder clay, or bowlder clay interbedded with sand and gravel, cling to the bluffs of the Little Miami at various places. From Redbank almost to Terrace Park the Pennsylvania Railroad follows the foot of such a terrace. The high isolated hill in Milford is a remnant of the same general level, likewise the two isolated hills standing in the valley a mile north of Milford. From these high points, remnants at the same level may be sighted, corresponding to the area shown on the accompanying map as terraces of the Illinoian Glacial epoch.

#### *Trough of Miami River*

**Dimensions.**—The immediate valley of Miami River from Middletown, Ohio, just north of this area, to Lawrenceburg, Ind., just west of it, is a clearly marked trench like that of the Ohio. It has even greater extremes of width (see Fig. 4, p. 25, also Fig. 6, p. 28). From Valley Junction (west of Cleves), where it receives the Whitewater, the Miami flows to the Ohio in a valley from two to three miles wide.

North of Cleves it diminishes in width to a point about one and one-half miles south of Miamitown. Here its width is only one-fourth of a mile from bluff to bluff. Thence northward it broadens to three-fourths of a mile, but contracts again at New Baltimore to less than half a mile. Two miles farther north it widens greatly and maintains a width varying from one and one-half to two and one-half miles to Coke Otto north of Hamilton. Here it broadens to four miles in the so-called Hickory Flats. It diminishes to one and one-half miles between Trenton and Excello and then broadens again into the extensive flat south of Middletown.

The depth of the trough grows less with distance from the Ohio. The general level of the upland within one or two miles of the bluffs remains between 800 and 900 feet above the sea, while the stream has a fall of four feet to the mile. The river at Hamilton is therefore 130 feet higher than at its mouth, and at Middletown some fifty feet higher still. Generally speaking, the bluffs near the northern edge of the area rise 100 to 200 feet above the river; at Hamilton 200 to 300 feet. Near the mouth a height of 400 feet is approached.

**Character of Bluffs.**—The bluffs of the Miami, while everywhere distinct, are generally less steep and more furrowed by small valleys than those of the Ohio. The extreme heights mentioned are generally several miles back from the flood plain. Exceptions to this rule are found in the narrower parts of the trench. The south bluff, southwest of Miamitown, is almost as high, and for three miles almost as unfurrowed as the south bluff of the Ohio between Constance and Bromley, Ky. But even at this place below Miamitown, the opposite bluff is much eroded and rises but gradually to the full height of the upland.

Other exceptions to the general character of the bluffs described are due to relatively recent and powerful erosion at the base (perhaps during the last glacial stage). Such an example is the beautiful escarpment stretching westward three or four miles from Symmes Corners, four miles south of Hamilton. All these features, width and depth of trough and form of bluffs, are important elements in deciphering the history which has given the valley its present form.

**Valley Floor.**—South of Hamilton the floor of this great trench consists almost entirely of flood plain, most of it still subject to overflow. A part of the floor north of Hamilton is of the same character. Here however is a widespread and important terrace built of sand and gravel and covered with fertile loam. Its surface is 620 to 640 feet high in the southern part and rises to 660 feet at the northern edge of the area and still higher near the bluffs where it merges with the floors of tributary valleys. This terrace constitutes the main portion of "Hickory Flats," one of the most famous farming districts in Ohio.



Hardly distinguishable from the gravel of this terrace are several areas of more undulating surface. The body of these is clay laid down by the continental glacier. (See topographic map in pocket.)

Several fragments of the sand and gravel terrace remain in the lower end of the valley; a very considerable one 540 feet high at Valley Junction from which the railroads obtain much gravel; and a similar one 560 feet high, similarly used, at Valley View north of Miamitown.

### *Norwood Trough*

A large valley, similar in almost every respect to that of the Miami, extends eastward from St. Bernard and Bond Hill. It contains the city of Norwood and the suburban villages of Oakley and Madisonville, and opens into the trench of the Little Miami. Its width is from one and one-half to two and one-half miles (see Fig. 4, p. 25). Its bluffs are like those of the Miami and Little Miami, distinct, but furrowed with minor valleys especially on the south side where the bluff is less abrupt than on the north. An exceptional stretch of bluff east of Madisonville is very steep and straight and almost free from gullies and ravines for more than a mile.

The uplands south of this trough (that is, the hill portion of Cincinnati) rise 700 to 800 feet above the sea; those on the north side 800 to 900 feet. The broad floor of the valley has an altitude of 600 feet, more or less. The valley is therefore perfectly distinct, having a depth of 100 to 300 feet with an almost flat floor bounded by hills on both sides.

The flat floor here mentioned is locally cut into by Duck Creek and at many places pierced by deep wells. Moreover, at its east end it terminates in a steep face 100 feet high overlooking the Little Miami, thus exposing the materials of the substructure. From such exposures it is known that the flat floor of the valley is composed of beds of sand, gravel, and clay, alternating with sheets of hard boulder clay.

It will be seen that this valley is much wider than that of the Ohio at any place except in the Cincinnati basin, yet its largest stream at present is Duck Creek which flows east and south from Norwood to the Little Miami. For so large a valley this stream is insignificant in size, no larger than some of those which descend the bluffs in ravines. A still smaller stream flows westward from Norwood to Mill Creek. Between the heads of the east-flowing and the west-flowing streams, this great valley has no stream at present.

### *Mill Creek Valley*

A striking feature of this area is the great valley which is occupied, except at its northern end, by Mill Creek, a small stream which issues

from the bluffs in a narrow valley, little more than a ravine, and bears the same relation to the great valley which it follows as Duck Creek does to the Norwood Trough:

Mill Creek Valley opens at the south end into the Cincinnati basin. Between that basin and Cumminsville (a distance of two miles) the valley is little more than one-half mile wide and bordered by abrupt bluffs. In this portion it strongly resembles the trench of the Ohio. At Cumminsville the valley turns east and merges with the Norwood Trough, the two together forming a continuous lowland on the north side of the island-like upland which is the chief residence portion of Cincinnati. These combined valleys form a lowland strip three to four miles wide trending north from St. Bernard and Bond Hill. At Lockland the valley divides, the western arm, occupied by West Fork of Mill Creek, coming to a head south of Glendale. The eastern arm continues northward to the point where Mill Creek issues from the east bluff, then curves to the west, merging into the trench of the Miami. Its width is one and one-fourth to two and one-half miles. Everywhere north of Cumminsville, the bluffs of Mill Creek Valley are similar to those along the Miami, being much indented and dissected by side streams and presenting to the valley the appearance of a range of rolling hills rather than that of a continuous escarpment.

Like the Miami trench, this valley decreases in depth toward the north. Its decrease is greater, however, because the northward rise of its floor is greater. Along a line drawn south from Lindenwald, the difference in elevation between the Mill Creek Valley on the east and that of the Miami on the west is about 30 feet, although this descent is not made abruptly or in a single step. The floor of Mill Creek Valley from this point east and south is nearly flat for a long distance. Much of it was swampy until artificially drained by the "state ditch." It consists of sand, gravel, mud, and boulder clay, now one, now another. For three miles west from Flockton it contains no stream.

#### *New Haven Trough*

It will be recalled that at a point near Venice, O., the Miami leaves its broad (two miles) valley and turns south into a narrow trench passing New Baltimore and Miamitown. The very wide trough which it follows to a point west of Venice does not stop there but continues westward to the Indiana boundary where it becomes the valley of the Whitewater which enters it from Indiana at Harrison (see Fig. 4, p. 25). This portion of the great valley between Venice and Harrison is so nearly like the great river valleys which it connects that the casual observer might fail to notice that it is not now occupied by the Miami River. Instead of being followed as a drainage line it is actually crossed by Paddy's Run, a small stream which emerges from the bluff on the

north and flows entirely across this broad valley to join the Miami in its narrow trench farther south. The bluffs of this part of the valley are similar to those of the Miami wherever the valley of the latter is broad. The floor is in large part mildly undulating glacial drift, but crossed by bands of sand and gravel covered by rich loam laid down by streams in the transverse valleys (see physiographic map in pocket). The entire expanse is not unlike the Hickory Flats north of Hamilton. The name *New Haven Trough* is taken from the village of New Haven which is centrally located and surrounded by a topography which is typical of the valley.

The depth of the New Haven valley is thirty to fifty feet less than that of adjacent portions of the Miami trench for the reason that its floor is that much higher.

#### *Union Village Trough*

From Middletown, O., southeastward to South Lebanon just east of this area, extends a prominent flat-bottomed trough very similar to the Norwood and New Haven troughs and Mill Creek Valley (see Fig. 4, p. 25). It is followed almost in a straight line by the Middletown branch of the Cincinnati, Lebanon and Northern Railroad. It is drained by two streams flowing in opposite directions from its center near Union Village; Dicks Creek flowing northwest to the Miami and Little Muddy Creek flowing southeast to the Little Miami. The fall of both streams is about five feet to the mile, but this is considerably more than the slope of the valley floor, for the streams in their lower courses have cut beneath that level. The valley is about two miles wide at the northwest, but southeast of Union Village it narrows to less than a mile. Near the eastern border of the area it is subdivided into two much narrower valleys, the one occupied by Little Muddy Creek, the other followed by the railroad. Beyond the eastern limit of the map, the valley again widens to about a mile.

The bluffs of this valley are from 100 to 200 feet high. In slope and appearance they are much like those of the northern end of Mill Creek Valley, always distinct, but never abrupt. They are carved into rounded hills, rising gradually from the valley floor.

The floor of this trough is mildly rolling near its ends, but elsewhere almost perfectly flat. A considerable area between the headwaters of its two streams is swampy. The material of this floor beneath the rich surface loam is like that of Mill Creek Valley, consisting of clay, sand, and gravel.

A striking feature of this valley is found in the abrupt hummocky gravel hills which partly fill it near Camp Hageman and subdivide it into two smaller valleys. (See Kames, pp. 108 and 155).

*Smaller Valleys*

The valleys described above are of distinctly larger dimensions than any of those which remain, and also of greater importance in the history of the present surface. But a few of the remaining valleys have much in common with these larger valleys in their relatively broad flat bottoms and pronounced bluffs. The most important of these are the valleys of four creeks which flow southeast into the Miami. Named in order from north to south, these are Sevenmile, Fourmile, and Indian Creeks and Paddy's Run. The floors of the first three consist mainly of alluvium, though not all liable to overflow at the present time. Since small streams require more fall than large ones, these floors rise rapidly up stream and the height of their bluffs grows correspondingly less. Fourmile Creek at Oxford, just north of the northwest corner of the area, has bluffs but little more than 100 feet high. The same is true of Indian Creek where it enters the area ten miles west of Hamilton.

The valley of Paddy's Run possesses interest of another kind. It has a complex history to be discussed later. (See p. 123). The abnormally wide lowland along this small stream is underlain by glacial deposits and only in small part by alluvium. Westward from Shandon, this valley is continuous with that of Dry Fork of the Whitewater, but it is not followed by a stream.

## CHAPTER II

# HOW BED ROCKS ARE MADE

### SOME GENERAL PRINCIPLES

**Bed Rock and Mantle Rock Distinguished.**—The expression *bed rock* is a common one and is essentially equivalent to *solid rock* when regarded as a continuous mass and distinguished from all the loose material which covers it. The earth's crust is made up essentially of solid rock. Bed rock is generally covered to a depth of a few feet, in some places several hundred feet, with loose or incoherent material called *mantle rock*. This loose material may be soil or subsoil or partly decayed rock in process of becoming soil; it may be sand, gravel, or clay laid down in layers by streams or otherwise, or it may be the unassorted sand, clay, and bowlders transported and left by ice. Whatever it be, it is certain that solid rock exists beneath, rarely more than a few dozen feet, never more than a few hundred.

**Igneous and Sedimentary Rocks.**—In this broadest and commonest sense the term bed rock means simply the "solid rock beneath." It has no reference to rock in *layers* or *beds*, though such a condition is more common in most countries than the opposite condition in which the rock is not thus subdivided.

In a general way the rocks which are not made up of layers or beds are the igneous rocks, that is, those which have cooled from a state of fusion. Such rocks do not occur in this region except as bowlders and pebbles in the deposits made by glacial ice. Such deposits will be described later but it is not necessary to discuss the nature of the individual stones.

Rocks which are not igneous were originally sediments. Sediment is laid down in layers or beds, generally by water, sometimes by wind. Hence the terms "sedimentary rock" and "stratified rock" are used almost interchangeably. The rocks of the area here considered are of this kind. The general principles governing their making are therefore described.

**Source of Sediment.**—Sedimentary rocks were not the original rocks of the earth's crust. The material to be deposited as sediment must first be derived from something else. It may come directly from other and older sedimentary rocks, but ultimately it had to come from rocks which were not sedimentary. Igneous rocks were the original source.

Such an origin is evident upon a mere casual examination of some rocks. Many rocks show to the naked eye that they are made up of fragments of others. This is very evident in conglomerate, sometimes called pudding-stone, and less evident but still plain in sandstone. Other rocks which are fine-grained, like clays and slates, show the same thing when examined under the microscope. All these are called *clastic* rocks from the Greek word meaning to break. Limestones are not clastic, for, while derived ultimately from other rocks, they cannot be said to be made up of their fragments.

**Deposition in the Sea.**—Sediment is carried by almost all surface waters, and deposits are thus continually made by streams and lakes, but most of these deposits are small in comparison with those on the bottom of the ocean. Moreover, most of those which are made on lake bottoms and especially on river bottoms are apt to be again washed away before becoming rock. Hence it is that far the larger part of the world's sedimentary rocks were first deposited as sediment on the sea bottom.

## HISTORY OF SANDSTONE AND CONGLOMERATE

### *Origin of Sand and Gravel Beds*

**Derivation of the Quartz.**—A careful examination of sedimentary and igneous rocks, even without a microscope, will show that some of the materials are identical in the two. This is especially true of quartz, the material of which sand grains are made. Granite, which is one of the most abundant igneous rocks, is made up of grains of three minerals, quartz, feldspar, and a dark mineral, commonly black mica. Generally these grains are much larger than sand grains and of irregular form. On a broken surface the grains of quartz look like bits of glass.

When granite is exposed to the weather, and especially to moisture in the ground, the other minerals decay but quartz is almost proof against all those agencies which cause other minerals at the surface to decay. When the other minerals decay the rock disintegrates and the quartz grains fall apart. They may be broken up into smaller and smaller particles by alternate heating and cooling.

**How Grains are Formed and Carried to the Sea.**—Sooner or later these bits of quartz are washed into some stream and the water dashes them against one another and against other stones, breaking them up smaller and sorting them out according to size. The fragments of quartz within a certain range of size are then called sand. At first the fragments are very angular and the sand is then called "sharp." As they are washed down stream the grains are subject not only to breaking but to the rounding off of their corners by grinding on one another. Most sand, however, which has been subject only to stream action is still relatively sharp.

**Experience of Sand on the Beach.**—After reaching the sea, sand is subject to the action of the breakers (Fig. 13). These may dash it to and fro on the beach for hundreds or even thousands of years. With the breaking of each wave the grain is washed upward on the beach, and in the interval between two breakers it rolls or washes back. Generally the breakers are coming in at an angle to the shore, so instead of being carried straight in at right angles to the shore, the grain is carried in obliquely but it slips out again at right angles. Thus it is dashed in and washed out continually, moving all the time along the shore in a zigzag line. In this ceaseless agitation by the waves, a grain of sand

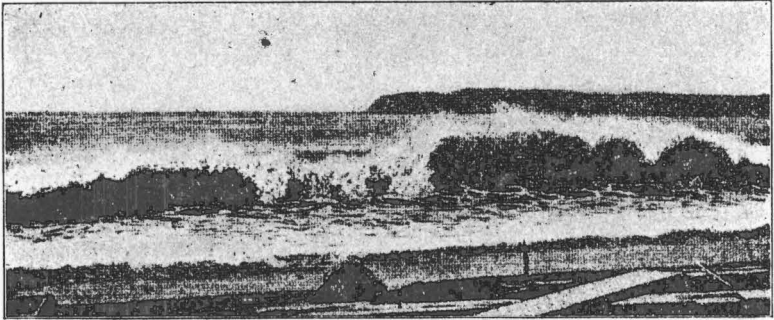

Fig. 13.—Breaking waves (Maury-Simonds).

may soon suffer more wear and rounding than in its entire journey by river to the sea. Beach sand is therefore less sharp than river sand derived directly from igneous rocks.

The experience of sand on the beach may be further complicated by wind. If much sand is blown toward the land it may pile up into dunes or traveling hills of sand. Grains of sand thus blown about wear one another more rapidly than when dashed one against the other in water. Dune sand is therefore still rounder (less sharp) than beach sand.

**Sand Carried Out by the Undertow.**—The water which travels toward the shore in a breaker travels out again at the bottom. This outward current at the bottom is called *undertow* (Fig. 14). Except under peculiar circumstances it is always present where there are breakers. From time to time, portions of the beach sand are caught in the outward current of the undertow and carried seaward on the bottom. Much dune sand shares the same fate, for the wind does not always blow toward the land. The sand dragged out by the undertow is spread out in a sheet or bed extending outward from the shore to a line where the undertow becomes too weak to carry it farther. This depends on the depth; the farther from shore and the deeper the water, the weaker the undertow. Generally sand is not carried out more than a few miles from shore; in exceptional cases a few dozen miles.

**Deposits of Gravel.**—From the same reasoning it follows that gravel must be still more narrowly restricted to the shallow water near the edge. The amount of agitation required in order to handle gravel is necessarily greater than in the case of sand, and the undertow, which weakens as it goes seaward, must drop the gravel first.

Much broader sheets of sand and gravel may be formed if the land is gradually sinking and the shore shifting. Then the zone of depositing sand and gravel shifts to follow the moving shore. When a bed of gravel or even of sand is thus made several hundred miles wide, it is evident that it was not all laid down at the same time, but the edge farthest from land was laid down first when the shore was farther out.

**Where the Ohio and Miami Derive Their Sand.**—In thinking of the vast quantities of sand carried by the Ohio and Miami rivers as

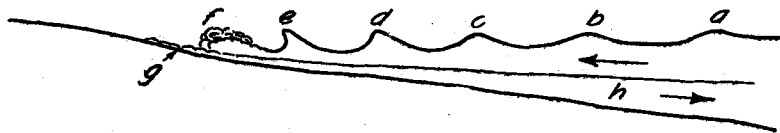

Fig. 14.—Diagram showing incoming breakers and outgoing undertow. Arrows show the movement of the water. *a, b, c, d, e*—waves advancing on shore, becoming shorter, higher, and steeper on front. *f*—breaker; *g*—out-rushing water of the last breaker; *h*—undertow.

on its way to the sea to form sandstone, it should be remembered that most of the sand carried by the Ohio is not derived first-hand from the igneous rocks. Most of the sand which this river carries comes from the breaking down of other sandstones, and the same grains may once have constituted still older sandstones. On the other hand, much of the sand now being carried by the Miami comes from recent glacial deposits, the glaciers having derived it directly from the igneous rocks of Canada. Some of it came down as sand, other parts were delivered to Ohio as boulders of igneous rock containing quartz. These rocks are now decomposing and yielding sand to the Miami in the manner described above. The Ottawa and some other Canadian rivers carry a still larger proportion of quartz grains which are making their first journey to the sea.

#### *Cementation Forming Sandstone and Conglomerate*

**Calcareous Cement.**—A bed of sand thus made is converted into sandstone by cementing the grains together. This is illustrated artificially in making common wall plaster in which the grains are cemented together by carbonate of lime (calcite). Some natural sandstone is cemented in the same way, for many natural waters carry much lime in



solution. If such water percolates through sand, the lime may be precipitated on the grains, coating them and causing them to adhere. The sands and gravels which partly fill the great valleys in this region are locally affected in this way, making hard plates or beds of sandstone lying between other beds which are still loose and incoherent. Often the cementing process, instead of affecting a whole bed, affects a spheroidal mass of sand or an irregular or curiously shaped mass. Such bodies are called sandstone concretions and are found embedded in the loose sand. The high bank extending east and west from Batavia Junction (Claire Station) south of Madisonville is one of the many places in this region where such curious concretions are found.

Gravel is even more frequently found cemented in this manner. There are few gravel pits in the area in which this tendency is not illustrated; sometimes so abundantly as to interfere seriously with excavation, as in some of the Norfolk and Western Railway gravel pits on the south side of the Little Miami opposite Terrace Park. Plate I-B illustrates the same feature in the pit at Linwood.

**Iron Oxide as Cement.**—Sand and (more especially) gravel may likewise be cemented by oxide of iron (iron rust). The iron is carried in percolating water in soluble form just as calcite is. When it is oxidized it becomes insoluble and is necessarily precipitated. This coats the grains or pebbles, causing them to adhere thus forming either beds or concretions of a brown color. These are not quite so common in this region as those cemented by calcite but they are not infrequent. Many concretions of this kind are picked up for "petrified potatoes," "petrified walnuts" and the like. Concretions of curious shape are also frequently mistaken for the work of Indians or Mound Builders.

**Siliceous Cement.**—The above illustrations of cementation by calcite and iron oxide are taken from local and superficial deposits on the land. The great beds of sandstone made beneath the sea are generally cemented by silica, which is chemically the same material as the quartz which constitutes the grains. There may be calcite enough mixed in to make the sandstone effervesce with acid, or iron oxide enough to make the stone brown, red, or yellow, but generally the real cement is silica. It is introduced in the same way as the other cements described.

The cementation of extensive beds is usually done after such beds have been buried by others. This is one reason why lake deposits and river deposits are less frequently converted into rock. Such deposits stand less chance of being well buried and more chance of being eroded away promptly.

#### HISTORY OF CLAY AND SHALE

**Minerals Which Decompose.**—It has been pointed out that sand comes from that constituent of igneous rocks which does not decay

but merely breaks up. On the other hand, most of the minerals in igneous rocks are subject both to breaking up and to chemical decomposition. Far the most abundant of these constituents is feldspar. It is that mineral which constitutes the larger part of granite and of many other igneous rocks. If the quartz in granite is clearly recognized, then the feldspar is practically all that is left and not black. So far as making sedimentary rocks is concerned, feldspar is the great representative of the decomposable minerals. It is generally among the first to decompose and when this is done the remaining minerals fall apart and the rock is *disintegrated*.

**Kaolin or Pure Clay.**—The most abundant substance resulting from decomposition is kaolin. This may be called *pure clay*. In its pure form (pure potter's clay) it is white and generally very plastic and has no grit even when taken between the teeth. It is rarely found in this condition. Even a slight color indicates some impurity. But though rarely found pure it is, next to quartz, the most wide spread mineral in sedimentary rocks, for it is the basis and characteristic constituent of all clays, and clay (or its consolidated form *shale*) is much more abundant than any other sedimentary rock.

Even pure clay is made up of individual grains, though very small, often of microscopic dimensions and in some cases too small even for the microscope (colloidal clay).

**Mud in Streams.**—When rock is once disintegrated, the decomposed and decomposable minerals are washed into streams along with the quartz and started for the sea, being carried as pebbles, sand, and mud. That which is classed as mud consists of the kaolin together with very small particles of any or all other minerals, including very small particles of quartz; in fact these are usually abundant. The mud which settles from the water of the Ohio or Miami is in many cases nearly one-half quartz.

It may be difficult to draw a consistent theoretical line between sand and mud but the following distinctions are useful. Sand consists essentially of quartz; clay, of kaolin with minute particles of any or all other minerals. Sand does not make quiet water turbid, but falls to the bottom; mud remains suspended, settling slowly and meantime clouding the water. When dry, sand is incoherent; mud forms clods or, if pulverized, dust. Sand *falls* through air; dust *settles*. *Mud* is a physical term and does not indicate any definite chemical composition. Mud once deposited in a geological formation is generally called *clay*.

As with the sand carried by the Ohio and Miami, so with their great burdens of mud, much of it is not derived directly from the decomposition of igneous rocks, but from older sedimentaries. It is not now possible to say how many similar journeys it has made to the sea, but originally it started from the igneous rocks.

**Deposition of Mud in the Sea.**—When mud reaches the sea it

is not, like sand, dashed to and fro by breakers, for the simple reason that, if so churned up, it remains in suspension. For the same reason it does not form beaches. Rarely even does it form the bottom in very shallow water which is agitated to the bottom. Remaining in suspension, it is carried outward where the water is quieter at the bottom because deeper. Here it has a chance to settle. If found on shallow and agitated bottoms, it indicates a constant and probably abundant source of supply, for the effect of agitation is constantly to move the mud to deeper and quieter water.

The above statements refer to the margin of the ocean where shallow water passes gradually to deep water. In enclosed bays or lagoons, however shallow, mud must remain and accumulate.

In all the above statements the word clay may be substituted for mud when not thought of in relation to the water which transports it. The brick clays of the Ohio and Miami flood plains are nothing but the mud once carried by those streams.

**Change of Clay to Shale.**—Shale differs from clay only in being consolidated into a firm rock. All the soft blue beds between the limestones in the quarries of this region are shale. Commonly it is called clay, sometimes incorrectly called soapstone. In an old exposure it is, indeed, generally again decomposed into clay, but where excavation reaches the fresh blue rock this shale is found to be a firm though not enduring rock.

Consolidation of clay into shale may be effected to some extent by cementing the minute particles together just as in the case of sandstone. A spectacular illustration of this is found in clay concretions, some of which assume very curious and even puzzling forms. But an important factor in the consolidation of clay into shale is pressure, just as two pieces of brick clay may be molded into a single mass by pressure. In the making of shale, therefore, it is important that the beds should be well buried by other beds. There is no extensive consolidation of our recent clays in this region corresponding to our prominent conglomerate and sandstone concretions found in the sand and gravel terraces of our larger valleys.

## HISTORY OF LIMESTONE

**Source of Lime for Marine Shells.**—The derivation of limestone from the original rocks of the earth's crust is by a more roundabout process. Most of the igneous rocks contain some lime but only in chemical union with other substances. It is freed from these only by decomposition, and then the lime is dissolved in water. In that way it passes to the sea. There it is abstracted from the water to form the shells and other limy parts of marine animals. Much lime is also

abstracted by some marine plants, especially algae. Were it not for this process the ocean water would contain, if that were possible, many times more carbonate of lime than it now contains of common salt.

These marine animals live and die in countless numbers, their limy shells accumulating on the bottom. Most of such life is in relatively shallow water (not over 600 feet deep) and hence within a few scores of miles, or at most a few hundred miles, from shore. This relatively shallow area is called the *continental shelf* because the descent to deep water beyond it is relatively steep (see Fig. 15).



Fig. 15.—Diagram showing continental shelf and edge of ocean basin. These slopes are at least five to twenty-five times as steep as in nature. *a*—coarser sediments; *b*—finer sediments and organic deposits; *c*—edge of continental shelf approximately 600 feet deep; *d*—thin deposits of very fine mud and organic remains.

**Ooze and Marl.**—Shells thus accumulated on the bottom are subject to disintegration. Where the water is very shallow they may be merely broken up by the agitation of the water. Out farther, where the water is deeper they may disintegrate in other ways. In any case they generally make a muddy or pulpy mass called ooze. It should not be forgotten that many of the so-called shells are tests of very minute organisms which do not live on the bottom, but swarm in countless numbers near the surface of the water. After their death their limy tests fall to the bottom. Hence much of the ooze is fine grained or muddy even without further disintegration. The extent to which plants aid in making such accumulations is undetermined.

If the sea bottom be lifted up and the ooze exposed in its unconsolidated condition it is an earthy mass called *marl*. It is rarely pure, generally containing a small or large admixture of clay.

**Consolidation Forming Limestone.**—If the ooze instead of being exposed by uplift is buried under later sediment, and time be allowed, it consolidates into limestone. The water which permeates it is strongly charged with lime in solution, that is, it is very hard. This lime in the water is partly precipitated, coating the particles and causing them to adhere as in the case of sandstone.

As thus described (and this is the most common case) the resulting limestone would be fine grained or dense like a few of the beds of the region here considered, or like the Dayton limestone, much used for building in the Miami Valley and Cincinnati. Often it happens, however, that whole shells or large fragments are incorporated. These

then become *fossils*, so abundantly seen in most of our limestones. Again, it often happens that most of the mass is dissolved and again precipitated, not at one time but slowly and progressively. Thus the limestone becomes a mass of small closely crowded or packed crystals and may be coarse in texture. Such a limestone when freshly broken reflects the light from numerous small facets. This condition is very common in most of the beds which are quarried in this region.

#### HOW THE CIRCUMSTANCES AT THE TIME OF SEDIMENTATION ARE RECORDED

A study of sediment forming at the present time shows that every change in circumstance or condition makes a corresponding change in

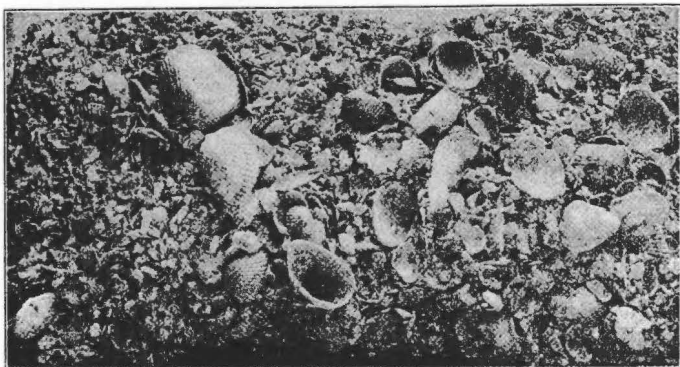

Fig. 16.—Modern shell limestone; coquina from Florida. (Scott's Introduction to Geology.)

the nature of the sediments or their structure. Reasoning the other way, it is clear that the great variety of features in our bed rocks give the clue to the circumstances under which they were laid down.

#### *Distribution of Land and Water*

The first and most important principle in this connection is that sediment is, and always has been, *as widespread as the sea* and, conversely, wherever sedimentary rocks of a given age are found, there the sea was *at that time*. Wherever sedimentary rocks of that age are absent, there was land at that time, or those sediments were eroded away in a subsequent land period. In this manner the map of land and water must be constructed for each epoch of geologic history. It will be found that shore lines have rarely stood still for any great length of time, as indeed most of them are not now standing still. In the main

the present deep oceans (beyond the continental shelf) have always been ocean, but most of the present area of land and shallow ocean have afforded a ceaseless change of pattern. A detailed study of the rocks in the Cincinnati area affords many illustrations of such shifting.

### *Arrangement of Coarse and Fine Sediment*

**What Conglomerates and Sandstones Indicate as to Nearness of Shore.**—In determining the conditions of former geologic times, the most important contrast among rocks has to do with the size of the particles which compose them. The coarsest of all maritime rocks are the conglomerates which are merely cemented gravels, the individual stones sometimes being boulders rather than pebbles. It is plain that all such were deposited at or near the edge of the water. If a bed of conglomerate be 100 miles square, the shore must have shifted during its making. The original bed of gravel began as a narrow strip and grew laterally as in the weaving of a rug. This occurs when the land is sinking. The outer or seaward edge of the conglomerate is older in point of time than the landward edge. By the time the latter was made, the former was already far from shore and covered by finer sediments. Strictly speaking the so-called broad bed or stratum of conglomerate is not a single bed, but the landward edges of many overlapping beds.

Such a formation is called a *basal conglomerate* because it marks the beginning of a new series of sediments after the area has been for some time out of the water. The whole of it is laid down near shore. Its pebbles are derived from the rocks which were being submerged. The principle here explained is an important one even in this area where there are no true conglomerates, because, as will be seen below, there are some beds consisting of shell fragments which indicate the same thing.

Sandstone does not necessarily indicate such close proximity to the old shore as conglomerate. It may and often does reach to the very shore, but it may also extend much farther seaward. Nevertheless, if a sandstone formation is very broad, say several hundred miles, the presumption is that the shore was shifted during its deposition. Frequently it happens that the same formation is a sandstone at one place and a few miles away a conglomerate. In such a case it may generally be inferred that in passing from the former to the latter, the old shoreline is being approached; but there are also other, less common ways in which the same effect may be produced.

**What Shale Indicates as to Nearness of Shore.**—Shale, on the whole, was made farther from shore than sandstone. This will be clear when it is remembered that mud is carried out in suspension

instead of dragged out along the bottom by the undertow. There is no definite limit to the distance which it may be carried, but most of it settles on the continental shelf except where that is very narrow. With greater distance from land, the process of deposition becomes slower and the beds thinner. Under special circumstances mud may be deposited very near the shore, as in a well protected bay, or where the supply of mud from rivers is excessive.

So far as *clastic* rocks are concerned, therefore, it is a general principle that (other things equal) the distance from shore varies inversely with the size of the particles, that is, with the coarseness of the sediments.

**What Limestone Indicates as to Nearness of Shore.**—In a very general way it may be assumed that limestone is made still farther out from shore, but this principle cannot be applied as a rule-of-thumb. Most of the shallow water of the ocean margin has some animal life though it varies greatly in abundance from place to place. Wherever life is, its calcareous remains tend to accumulate, but if waste from the land is accumulating more rapidly at the same place, then the calcareous matter will simply form an ingredient of the clastic beds and will not make limestone. It is only where sediment from the land is very small or absent, or where the remains of life are superabundant, that the latter make limestone. It is purely a matter of proportions.

It is plain then that limestone has the best chance to form at a considerable distance from land, beyond the limits of abundant mud. On the other hand, if little or no sediment is coming from the land, limestone may be formed to the water's edge. This occurred repeatedly in the history of the Cincinnati region. Some limestones here consist entirely of shell fragments broken up and washed about near shore like sand or gravel. In certain cases it appears that older shell limestones had been raised above water and, while sinking again, the waves beat to pieces the older formation and the fragments were again deposited, making a new bed of later age. This new bed is in principle a basal conglomerate, though it is not generally so called because of the confusion which might arise from calling the same rock both a limestone and a conglomerate. The coarse fragmental limestone at the top of the Trenton or base of the Utica shales is believed to be of this character. Likewise the similar limestone at the top of the Eden shales or base of the Fairview.

**Gradation Among Different Kinds of Sedimentary Rocks.**—Since the proportion of mud to calcareous matter increases gradually toward shore, it is plain that a formation may be pure limestone at one place, argillaceous (clayey) limestone at another, and shale at another. The same formation may likewise grade from shale into sandstone. There are no hard and fixed limits between these types. The Eden shale of the Cincinnati region, when traced southward into Kentucky, becomes locally a sandstone.

*Structural Features of Sediment Interpreted*

**Features of Sandstone.**—An examination of the grains of a sandstone reveals various circumstances of the time. They may be coarse and angular indicating little or no wear. This is especially significant when fragments of feldspar are mingled with those of quartz. Ordi-

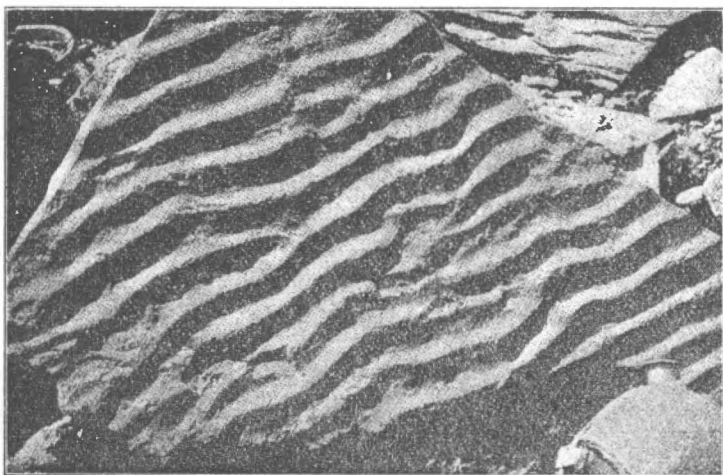

Fig. 17.—Ripple-marked sandstone (Fairbanks).

narily feldspar decomposes or is comminuted to mud before reaching the sea. Its survival means that it came from near at hand or that the climate of that time was arid, thus favoring the disintegration of rocks but not their decomposition. Some such rocks were "subaerial" sediment, that is, they were deposited on the land as stream sediments.

The upper surface of a bed may be ripple marked indicating very shallow water (Fig. 17). A thick horizontal bed of sandstone may be made up of thin oblique laminae (cross bedding) indicating that the bed grew laterally after the manner of a sand bar in a current (Fig. 18). This again indicates very shallow water. Even the color is significant, red and brown sandstones generally being deposited in an arid climate, since abundant decaying vegetation tends to decompose the iron oxide which gives the color.



Fig. 18.—Cross-bedded sandstone (Blackwelder and Barrows).



**Features of Shale.**—The local conditions attending the deposition of a shale leave corresponding records. Shales perfectly free from grit must have been laid down in very quiet water. Black shales are colored by carbonaceous matter and therefore indicate the presence of life, usually vegetable. Mud cracks are often well preserved and point to the same circumstance which causes mud cracks now, namely, alternate flooding and drying out, probably in flats along the shore alternately submerged and laid bare by tides.

**Features of Limestone.**—Some of these same features are present in limestone to indicate the circumstances of its making. It may be cross-bedded though this feature is not common. It may also be ripple-marked. A large size ripple, two to four feet between crests, is not uncommon in this region (Fig. 19). The ridges or crests of these ripples are always made of fragments of shells, evidently swept up into ridges on a shallow bottom. Pure limestone indicates a clear sea and argillaceous limestone, a sea more or less turbid.

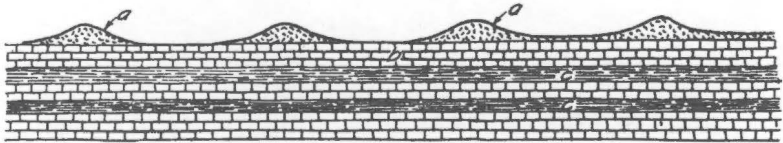

Fig. 19.—Diagram of large ripple marks on limestone, two to three feet from crest to crest. *a*—fragments of shells, etc., not much worn by water; locally (at the right) continuous from crest to crest; elsewhere absent between ridges; *b*—dense blue limestone; *c*—shale.

**Alternation of Sediments.**—A change from one character of sediment to another indicates some geological *event* or change of conditions. A single section exposed in sinking a shaft may pass through all the kinds of rock here mentioned and, it may be, coal beside. If a stratum of sandstone is overlain by one of shale, and that by a stratum of limestone, the succession may indicate either one of two processes. The place may have been near shore when the sand was deposited and gradual sinking may have deepened the water, at the same time removing the shore, causing the sediment from the land to become finer in grade and less in amount until it was greatly exceeded by organic remains.

With no movement of the water level and no change in the position of the shore, the same progressive change in sediment may be brought about in another way. Assume the land at first to have been high enough to give the streams sufficient power to carry down much sand to the sea. With the progress of erosion, the land becomes lower, the streams less steep and swift. At length they carry only mud. With continued erosion the land is reduced approximately to sea level and

the streams are almost without fall and without sediment. The adjacent sea is clear, and calcareous remains predominate over terrigenous sediment up to the very shore.

These two processes may be combined or may be complicated by the assumption of warping, raising land here and depressing it there and changing the whole map of land and water. Further complexities may be introduced by assuming the climate to change, also by assuming ocean currents to shift.

The operation of the two chief factors here named is shown in the following table.

*Succession of Strata Interpreted in Two Ways*

Explained by change in sea bottom	Succession of strata	Explained by changes on land
The last change is reversed.	4. Shale.	Renewed uplift of land has somewhat revived erosion.
Subsidence has so far removed the shore that little mud reaches the place. Animal life flourishes.	3. Limestone.	The land is reduced nearly to sea level; streams carry little load except in solution.
Subsidence has deepened the water and removed the shore.	2. Shale.	The erosion cycle has progressed; the land is lower; slopes less steep; streams weaker; carry mainly mud.
Shallow water near shore.	1. Sandstone.	The land is sufficiently high and streams have sufficient power to carry coarse sediment.

READ UP

READ UP

The rocks of the Cincinnati region present a remarkable illustration of frequent alternation between terrigenous sediment and organic accumulation. Doubtless crustal movements, erosion cycles, and the shifting of ocean currents all played their parts in causing the frequent shifts from the one condition to the other. Climatic oscillations may also have been important. The almost rhythmic change at short intervals suggests a possible relationship to certain oscillations of climate. Rhythmic recurrence at short intervals is not known to be characteristic of the other factors named.

*Fossils and Their Use*

**What Constitutes a Fossil.**—A fossil is any evidence of life in former geologic time. As known in this region such evidence is usually found

in petrified sea animals especially their shells. It is not necessary, however, that remains be petrified. The younger rocks furnish many fossils whose substance is the original material of shells, bones, or even wood, preserved from decay. Even the hair and flesh of animals of the Glacial Period preserved in the ice of the far north are fossils. The animals or plants may belong to species still living, but the word fossil should not be used for remains of existing species taken from deposits which are still forming. Many fossils are mere impressions such as footprints, or the sediment which filled shells and was preserved as casts.

**Petrification.**—As stated above, the fossils abounding in this region are petrifications. Despite the fact that limestone is largely made of shells, the present substance of any particular fossil shell is not that which constituted the living shell. If anything of that remains it is merely incidental. The water which once percolated slowly through the mass has removed the original substance of both shell and flesh, molecule by molecule, and substituted for it the carbonate of lime which it carried in solution. The distinguishing feature of petrification is that the form is preserved while the substance is changed. Even the structure is sometimes preserved, as in case of the cells in petrified wood. While petrifications in limestone are most common, the material is often silica, as in most petrified wood. It may be various other substances which abound in mineral veins.

In order that a shell may be fossilized it is necessary that it be incorporated into the sediment and protected from such decay as disintegrates the rocks and makes soil. It must therefore be buried by other beds. Its chances of survival are small unless the bed is then consolidated.

**Scientific Value of Fossils.**—The most evident use to which fossils may be put is in the study of the evolution of forms of life. Fossils of related species may thus be arranged in series according to the line of descent. Those which come from the lower rocks necessarily represent the earlier forms. On the whole the earlier are simpler and the later forms are more complex and higher. By arranging species in the order of time the principles may be seen, according to which development proceeded.

**Practical Use of Fossils.**—The great practical use of fossils depends on the fact that types of life have not only *come* but *gone*. All are more or less temporary. Geological and biological evidences go to show that each type came into existence but once and, having become extinct, never returned. All rocks containing one type of fossil must have been made while that form was living. It is assumed that beds containing fossils of the same species were deposited at the same time. Thus rocks, the world over, are classified and correlated according to the time in which they were made.

This general principle would be easily applied if each species had lived only during the making of a single formation. Some of them did, but others continued to thrive throughout the making of dozens of formations. Moreover animals migrated in colonies then just as they do now. This took time, and at the place where they first bred they are found in older deposits than at points which were reached after slow and lengthy migrations. But despite such complications the rocks underlying civilized countries are coming to be classified as to age with a considerable degree of accuracy and consistency, so that rocks of a given age may be known by their fossils wherever found, despite their differences in physical character.

Fossils may be considered as labels on the rocks in which they occur, stating their age and their relative position above or below other rocks in the column. Without the study of fossils the science of Geology and its practical application would still be in a very undeveloped condition.

### *How Sedimentary Rocks are Grouped*

**Various Units Defined.**—In the description and discussion of sedimentary rocks it is impossible to describe each layer separately or to delineate it on a map. It is generally necessary that a large number of layers be treated together as a unit as in the case of our limestones and shales. The terms used in such grouping have technical meanings and must not be confused. The word *bed* is used by geologists in the same sense as by quarrymen. It implies that the rock separates along certain planes, due to the manner of its deposition. These planes are called *bedding planes* and the thickness of rock which is thus easily separated from its neighbors is called a bed. Adjacent beds may be of different material, as is commonly the case here where limestone alternates with shale; but many quarries show bed after bed of the same rock easily separated. The word *stratum* (plural *strata*) applies either to one bed or many beds in contact, so long as all are of the same material. In other words, a stratum must not be separable into beds of two distinct kinds. In this vicinity the word *stratum* would mean about the same as *bed*, since single beds of limestone usually alternate with beds of shale.

Generally a great number of beds, and often of *strata*, are taken together for purposes of discussion and geologic mapping. The larger unit thus made is called a *formation*. This is the most essential term in the grouping of beds and it should not be used in any other sense. On detailed geologic maps each formation is distinguished by a separate color or symbol. It may sometimes be subdivided into two or more *members*, or it may consist of a single *stratum* or even a single bed. Division into formations is universal, but in many cases there is no

need for division into members. Just as the dollar is the unit of our currency, though fractional parts are much used, so the formation remains the essential unit for sedimentary rocks though it may be subdivided into members as is done with most of the formations in this area.

The most important unit larger than the formation is the *system*. Parts of two systems are shown in this area, the Ordovician and the Silurian. The meaning of the terms *series* and *group* is sufficiently clear from their use in the table on page 59 and in the discussion which follows.

**Terms Denoting Divisions of Time.**—Two names indicating units of geologic time are also important. *Period* is the time name corresponding to a system of stratified rocks. Those of this area were deposited in the Ordovician and Silurian periods. The word *epoch* denotes a shorter lapse of time. It may be the time during which a formation or a series was made, or a time in which the region was above water and no sediments were forming.

### *Unconformity*

It has thus far been assumed that all beds were laid down one after another in horizontal position and separated from each other only by bedding planes. Beds thus laid down are said to be *conformable*.

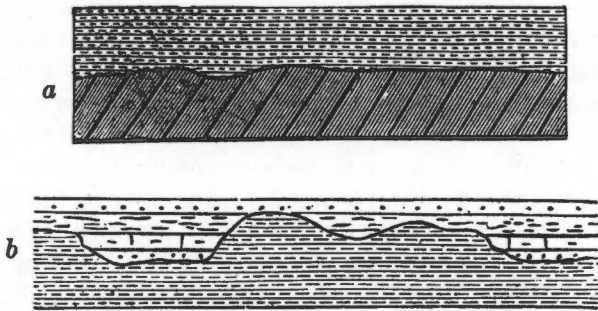

Fig. 20.—Diagrams showing unconformity. In the case represented by the upper figure (a), the old strata were uplifted, tilted, and deeply eroded, then sank beneath the sea and were covered by later strata. In the case represented by the lower figure (b), the older strata were uplifted without deformation. Erosion and later submergence followed as in the former case. (After LeConte.)

Frequently, however, such rocks are raised above the sea and eroded. When the land sinks again beneath the sea and receives new sediments, the new beds are separated from the old, not by a bedding plane but by an erosion surface. The two series of beds are then said to be *unconformable*. Figure 20a shows *unconformity of angle*, not illustrated

in this area. Figure 20b shows unconformity of erosion only. It is exemplified in this area by the relation between the glacial formations and the older bed rocks.

Another type of unconformity known as *overlap* is of special interest in this area. It may be described as follows:

All the formations known in any one area constitute the *column* of rocks for that area. Such a column for this area is shown on page 59. In another place 50 miles distant in any direction, the column of Ordo-

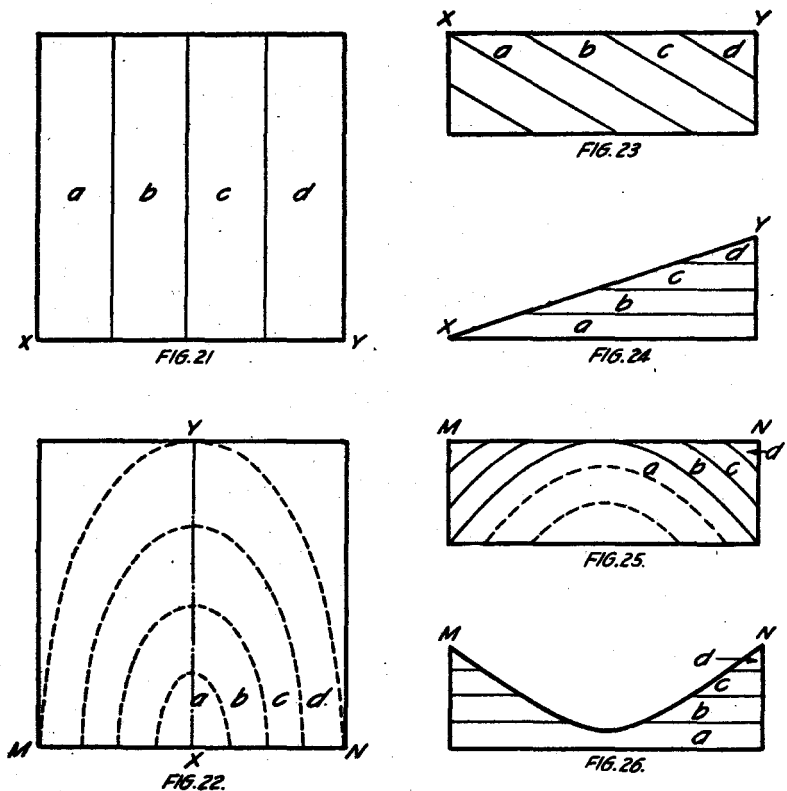

**Figs. 21-26.**—Diagrams to illustrate the nature of geologic maps. Fig. 21 represents a geologic map in which (a) is the lowest and oldest bed and (d) the youngest. Figs. 23 and 24 are two cross sections, either of which is consistent with this map. Fig. 22 is also a geologic map in which (a) is the lowest and (d) the highest bed. Its cross section along the line MN may be either as shown in Fig. 25 or as in Fig. 26. In the former case its section along XY will be as in Fig. 23; in the latter case as in Fig. 24.

vician and Silurian rocks would be somewhat different. Some formations present in one area would be absent from the others. This is because there were epochs in which the one area was sea and the other land. If three or four formations were made during the time that the

land was sinking beneath the sea, each successive formation would *overlap* its predecessor. The exposure of a complete section at any one place might give no hint of an unconformity, that is it might not show that any formations were missing until compared with sections from other places. In this area and adjacent areas a number of formations or members are seen to overlap their predecessors. In many cases this is the only means of knowing that the locality was land for a part of the time.

### *Geologic Maps*

It is the function of a geologic map to show what formation immediately underlies the mantle rock at every place. This is done by using a different color for each formation. The mantle rock is ignored.\* If the strata are horizontal the highest in the column must occupy the highest ground. On the other hand if the surface is nearly horizontal and the strata are inclined or dipping, the direction of dip will be from the outcrop of the older toward that of the younger formations. A study of figures 21-26 will make these statements clear.

---

\*Sometimes it is necessary to make two geologic maps of the same area, one showing the several formations of the bed rock and another showing the unconsolidated formations included in the mantle rock. The first is illustrated by figure 3, page 22. The second by the physiographic map (in pocket).

## CHAPTER III

### BED ROCKS OF THIS AREA<sup>1</sup>

#### GENERAL CHARACTER

**Limestone and Shale.**—The formations which underlie this area consist almost exclusively of shale and limestone arranged in nearly horizontal beds. Sandstone is almost totally wanting. Beds of limestone and of shale alternate at frequent intervals, but the total thickness of the shale greatly exceeds that of the limestone. The limestone consists of beds from an inch in thickness to more than a foot, though beds thicker than eight or ten inches are very rare. Two beds of limestone are rarely found in contact. Generally they are separated by beds of shale. This intervening shale may be as thin as paper or there may be five or ten feet of shale practically free from limestone.

One of the most striking features of the rocks of this area is the vast number of fossils, especially in the limestone. It is difficult for the people of southwestern Ohio and north-central Kentucky to realize that most of the people of the world have never seen a fossil in the rock. Here it is very rare to find a large piece of limestone without them.

**Impurities and Gradation.**—While in general the limestone is easily distinguished from the shale, it is far from pure. Its impurities may be from a sixth to a fourth of the entire mass. These impurities are of the same material as the shale. If they were deposited alone without the limy material they would have made shale. In similar manner the shales of this region contain calcite (carbonate of calcium); it may be as much as five or ten per cent. In occasional masses this is very much increased and in such rare cases the distinction between limestone and shale is hard to make. Certain shales are also locally arenaceous (sandy) and grade into pure sandstone, very sparingly found in the area.

**Structure.**—The strata in this area are not quite horizontal. They dip slightly in all directions from a point about seventy-five miles south of Cincinnati in Jessamine County, Kentucky, not far from High Bridge. In this area the steepest dip is toward the north, generally less than six feet in a mile, but there is also a dip toward the west from Cincinnati. There are local dips toward the east but these do not continue far. On the whole the westward dip exceeds the eastward, throughout this

<sup>1</sup>Published by permission of the Director of the United States Geological Survey.



area. None of these dips are sufficiently large to be observed in a single exposure. They are determined by noting the heights at which the same formation crops out at different places.

The dips within this area are also apparent on the geologic map (Fig. 3, p. 22). There it is seen that the oldest and lowest formations come to the surface near Cincinnati and that in journeying east, west, or north from that place, other formations successively younger and younger appear. As the general level of the country is not far from uniform, this arrangement of formations on the geologic map means that the rocks are slightly inclined. They are, in fact, exposed like shingles on a roof. (Compare figures 22 and 25, p. 53).

**Total Thickness.**—The vertical distance between the lowest point in this area (where Ohio River leaves it) and the highest (near the northwest corner) is about 530 feet. If, therefore, all beds were exactly horizontal, the total thickness of all the beds exposed would be just 530 feet. The fact that the beds are not quite horizontal but dip in a northerly direction makes the thickness of exposed beds somewhat greater.

A more important factor in computations of thickness arises from the fact that the nine formations exposed in this area vary in thickness from place to place and probably no two of them have their greatest thickness in the same locality. If the maximum thickness of all the formations be added together, the sum would be about 800 feet.

**Division Into Formations.**—As stated above these 800 feet are divided into nine formations. Some of these are sufficiently distinguished from their neighbors in physical appearance so that they may be recognized without expert knowledge. For example, the limestone quarry beds may thus be distinguished from the shale beds from which brick is made, but even in such cases it is generally hard to locate the exact line of separation. Subdivisions made by this criterion alone would have little value because the divisions recognized at one place could not be identified at any considerable distance. The formations used by geologists in this region are based largely on fossils.

**Local Variation.**—While the formations in this area are not boldly distinguished from their neighbors above and below, it is also true that the same formation has not the same character or appearance from top to bottom. The color, or the proportion of limestone to shale, may be different at different levels in the same formation.

When traced from one locality to another within short distances, the general character of each formation remains the same, but the exact order in which its limestones and shales occur, and even the proportion of limestone to shale, may vary from place to place. This change from place to place corresponds to what is observed in sediments now being laid down in the shallow sea. It is sand at one place, mud at another, and limy ooze at another, all perhaps burying the same species of shells. In a few years or a few hundred years the character of sediments being laid down in the different localities may be exchanged.

## GENERAL CONDITIONS DURING DEPOSITION

**Epicontinental Seas.**—The general conditions of the seas in which our bed rocks were deposited are plainly revealed by the rocks themselves. The sea was shallow. Central North America (or any other



Fig. 27.—Photograph of Jones model of the earth showing continental shelf (epicontinental seas) and deep ocean basins. Contrast depth of Hudson Bay with that of the ocean to the east; also the borders of Florida with the central part of the Gulf of Mexico. Vertical exaggeration large. (Chamberlin and Salisbury, *Geology*, Vol. 1).

continent) never was sea in the same sense that the Central Atlantic is sea, that is, it never was *ocean basin*. It was always a platform separated from the deep ocean basin by relatively steep slopes. Instead of thinking of the Mississippi Valley as having once been ocean basin, it is a truer conception to think of the ocean basins as somewhat "more than full" so that their waters submerged the lower parts of the continents. Central United States was sometimes a low plain like the Gulf States at present, and sometimes a submerged plain like the banks of Newfoundland or the very shallow Hudson Bay or North Sea (Fig. 27). Such seas are called *epicontinental* (that is, "on the continent"), and are not parts of the deep sea like the Gulf of Mexico or the Mediterranean.

**Evidences of Shallow Water.**—This relation of the water to the land is plainly shown in the rocks of the Cincinnati region. Some of

the limestone beds are locally ripple-marked (see p. 47), indicating a depth of water so small that its waves acted with vigor on the bottom. All the forms of life were those which inhabit the shallow waters of the continental shelf. There are no deep sea forms among the fossils. Some of them, like the trilobites, had good eyes, indicating that they lived in the light. Nearly all of the light of the sun's rays is lost at a depth of 600 feet and most of it at 300 feet. Many shells are broken up as if by the dashing of waves, and it is largely these shell fragments which have been swept up into roughly parallel rows and ridges two or three feet apart, making the large size ripple marks mentioned above (p. 48). At places this debris of shells constitutes a sheet with a flat base but rippled surface above. Elsewhere the sheet was so thin or the wave action on the bottom so strong that all the material was disposed in roughly parallel rows or crests several feet apart, the intervening trough being swept clean (Fig. 19, p. 48).

**Evidences of Low Land.**—If it is plain that the waters were generally shallow, it is equally plain that the land which furnished the sediment was generally low. High land would have involved swift streams and these would have carried sand and gravel, becoming later sandstone and conglomerate. The rivers carried only mud, like the sluggish rivers of our Gulf Coastal Plain. Moreover, high lands would have afforded, at least locally, steep cliffs along the shore, and these would have yielded fragments, at first angular, making breccia if consolidated, or later rounded by the waves making gravel and, when consolidated, conglomerate.

That the sea was warm is indicated by the extremely varied and abundant life.

**Local Rising and Sinking.**—Not only were the seas shallow and the land low, but there were almost constantly slight upward or downward movements of the land. To the eye all these formations are horizontal, but when a section of one locality is critically compared with that of another some miles distant, it is often seen that certain beds or members are present in the one and absent from the other. This means that during the time of their deposit, there was sea where they are now found and land where they are absent, or, if there was sea and deposit at both places, one of the localities was later raised above the sea level and the deposit eroded away. In either case crustal movements are indicated. If the rocks of the central Ohio Valley be considered in sufficiently small units or "members," it will be seen that many of them occupy only a part of the region, no two members covering exactly the same area. Moreover, each may be thick at one place and thin at another. Instead of one widespread uniform sea covering the whole region from the beginning of sedimentation to its close, the sea for a part of the time must be thought of as a bay, or several bays, separated by low peninsulas and islands, the whole surface constantly warping, shifting the bays now here now there, making them large or small or

absent according to the amount of elevation. There is nothing unusual about such behavior of the earth's crust. Similar movements are at present affecting the edges of the United States and perhaps the center also, though it is not so readily apparent there as it is along the coast.

**Table of Formations.**—The several formations in the area here described are listed in the table below from the youngest at the top to the oldest at the bottom. Their subdivisions (members) and groupings are likewise shown. It will be observed that some of the familiar names applied to rocks in this region are names of members, not of formations. Such is the case with the Fairmount limestone, in which most of our quarries are opened. Likewise, some names in popular use are group names, for example, the Eden shales.

The formations of the Richmond group at the top of the column, and especially those of Trenton age at the bottom, are much less abundantly represented in this area than those of the Maysville and Eden. All the groups mentioned below are known throughout this part of the United States as the Cincinnati series, indicating that they are best known and have been most thoroughly studied in this vicinity.

*Column of Rocks for Cincinnati and Vicinity*

Group	Formation	Member	Thickness, in feet	Character
Richmond	Whitewater formation	-----	50 to 100	Shale and impure limestone roughly bedded.
	Waynesville	-----	85	Blue shales, locally marly, with gray limestone beds.
Maysville	McMillan formation	Mt. Auburn concretionary shale	20 to 35	Blue shale with irregular or concretionary beds of limestone.
		Corryville shale	35 to 50	Shale with thin beds of limestone.
		Bellevue limestone	0 to 23	Very fossiliferous limestone.
	Fairview formation	Fairmount limestone	70 to 85	Predominantly limestone with subordinate shale.
		Mt. Hope shale	16 to 50	Predominantly shale, but containing many beds of limestone.
Eden	Latonia shale	-----	180 to 230	Blue shale with occasional limestone beds.
	Utica shale	-----	9 to 24	All shale.
	Cynthiana formation	-----	100	Chiefly limestone, but with much shale near the top.

*Cynthiana Formation*

**General Description.**—The lowest and oldest beds which come to the surface in this area belong to the Cynthiana formation of Trenton age. In Ohio the name Trenton is popularly associated with oil and gas, generally from great depths. The beds here exposed are continuous with the deeply buried oil and gas bearing formation in other parts of the State, but here they are brought to the surface by the Cincinnati anticline. Even at this place they would not reach the surface were it not for the deep valley which the Ohio has cut. If the deposits made by water and ice in our great valleys were removed, the Ohio, Miami, and Little Miami would all be found running on beds and between banks of Trenton strata.

The Trenton is commonly thought of as a limestone and much of it is; but its upper beds, fifty feet or more, the only portion exposed in this area, contain much more shale than limestone. Beneath the beds here exposed is solid limestone which is at places sixty feet in thickness (the so-called Point Pleasant limestone). In drilling wells it is encountered at levels not much below that of the Ohio channel. The driller knows by the behavior of his tools that he has reached solid limestone without shale. This he calls the Trenton, but in scientific usage the name has never been so restricted. These deeper limestone beds come to the surface and are quarried near Point Pleasant on the Ohio River about twenty-five miles above Cincinnati. The best exposure of rocks of Trenton age in this area is in the south bank of the Ohio at West Covington for a stretch of a mile eastward from the Cincinnati Southern Railway bridge. Here they form the rocky bank to a height of fifty-three feet above low water. In general the proportion of limestone to shale increases with the height above the river, the first fifteen to twenty feet being almost exclusively shale.

Several of the limestone beds in the upper part of this exposure are noteworthy because composed in large part of broken shells, as if dashed to pieces by waves on or near shore. Large undulations or ripples on the upper surface of these beds are formed by the sweeping up of these shell fragments into ridges by the waves on a shallow bottom. (See p. 48.)

**Fragmental Limestone at Top.**—The topmost bed of the formation contains these features with still another. Incorporated within it are balls or fragments of clayey rock, evidently derived from the wasting of a lower bed. With these are large irregular slabs of limestone, some of them two feet in diameter, evidently derived from the breaking up of an older bed. These slabs have been but little worn by the water. When brought into their present place they were embedded in a matrix of broken shells and crinoid stems, largely the latter. All the features indicate that an old sea bottom had become dry land and that when the land again sank the readvancing waves broke up and redeposited

the topmost beds of the old formation. Perhaps the new deposit thus made belongs more properly to the epoch of the overlying group (the Eden), but it has become customary to class it with the similar limestone below and to ignore its age relations with the soft shale above.

**Break in the Record of Life.**—The example here described is one of the best, but by no means the only example in the area, of beds which indicate that deposition was interrupted by emergence and then renewed by submergence. In all such cases the time during which the area was dry land was left without a record in the rocks. Not only that, but erosion was meantime destroying the last records made. During such intervals the evolution of marine animals was continuing in the seas elsewhere. When submergence again occurred, the later forms of life came in and were incorporated as fossils in the new sediments immediately above the antiquated forms in the beds just below the unconformity. In this particular case the gap in the record is small, but it separates the beds of Trenton age from the Eden and the Mohawkian series from the Cincinnati. Ninety per cent of the species in the highest beds of the Cynthiana failed to reappear in the lowest beds of the Eden.

**Dips.**—From West Covington the top of this formation dips westward, falling forty feet in the next eight miles. West of that are no outcrops because of alluvium and debris from the bluffs. Within five miles eastward from West Covington the top of the formation sinks almost to the river level. From this lowest point (opposite Dayton, Kentucky) the formation again rises as the Ohio is ascended, until, at New Palestine, where the Ohio enters the Cincinnati quadrangle, its upper surface is nearly 100 feet above the river. It appears therefore that the formation rises toward both the south and east, but there are also minor lines of folding.

Less satisfactory exposures than the one at West Covington may be seen at the mouth of the Licking (west side) and at various other points on the Ohio and Licking.

#### *Eden Group*

The Eden group, consisting largely of shales, takes its name from Eden Park in Cincinnati, overlooking Ohio River. In the steep bluffs leading down from this park to the river these shales are well exposed. In scientific usage the Eden shales are divided into two formations of very unequal volume, the Utica below and the Latonia above. The lower one, while small at this place, is full of scientific interest, and is the local representative of what is elsewhere a very important formation.

#### *Utica Shale*

**How the Epoch Was Inaugurated.**—It will be remembered that the topmost beds of the Cynthiana formation consist largely of limestone,

whose ripple marks and broken shells afford sufficient evidence that the deposit was made in very shallow water. Presumably this shallow water was very near the shore. It was shown on page 46 that limestone can be formed near shore only when the land is very low and yielding little sediment to its streams and thus to the sea. This was no doubt the condition of the land near the close of Trenton time. That epoch was brought to a close in this vicinity by the rise of the shallow bottom above the level of the sea. A land epoch then followed, after which renewed submergence introduced the Utica epoch. The first deposit on the bottom of the Utica sea was the fragmental limestone described above as commonly classed with the Cynthiana. It can scarcely be said to have been formed *after* submergence, but rather *during* submergence by the waves which beat upon the slowly receding shore. At places this wave-and-current work altered the limestone so little that it can scarcely be said to be destroyed and redeposited. Its fragments are Cynthiana fragments, and its fossils are Trenton fossils, simply broken up and rearranged by the waves of the Utica sea. When any one spot had been actually submerged, the nearness to shore and the turbidity of the water was such that mud was deposited on the bottom. This mud became the Utica shale. It is generally less distinctly blue than the shales of the higher formations. It inclines more toward yellowish, brownish, or greenish-gray shades.

**Thickness and Geographic Relations.**—At West Covington the Utica shale is only nine feet thick. Westward from that point it becomes still thinner, and disappears or “pinches out” before Andersons Ferry is reached. This indicates that land lay west of that point, while an arm of the sea on the east was receiving sediment from this and other shores. Eastward and farther from shore the sea came in sooner and was deeper. The formation thickens in that direction to twenty-four feet at New Richmond. Here it is about one-half limestone.

Going south to central Kentucky, the formation pinches out as it does to the west, but northeastward it thickens greatly, becoming 300 feet in northeastern Ohio, and passing into the great formation known as the Utica shale in New York. Through all this distance many of its fossils are identical. It is evident that in the continual warping and waving of the earth's crust, causing an ever changing pattern of low land and shallow water, the Utica sea reached this region in the form of a bay which gradually expanded southwestward from New York. In that region to the northeast, the submergence began much earlier, and the sediments (likewise shales) are very thick, but the submergence reached this region so late that there was time for but little sediment.

Other good exposures are at New Richmond (twenty-four feet), in the bank of Ohio River one-half mile below Brent, Ky. (fifteen and one-half feet), and near the mouth of Three-Mile Creek south of Newport.



A.—Waterfall in West Fork two miles above Cumminsville. The rock is Eden shale. The fall is occasioned by the beds of limestone which appear in the gorge wall at the left.



B.—Fairview formation (quarry beds) near the Bellevue Incline, Cincinnati, capped by the Bellevue member of the McMillan formation. (See p. 67.) (Photo by Bassler.)



*Latonia Shale*

**Character.**—Resting on the Utica shale, or on lower formations where that is absent, are more than 200 feet of shale with very subordinate amounts of limestone. This is the Latonia<sup>1</sup> shale, so named from Latonia, Ky., at the southern edge of the city of Covington.

As compared with the Utica shale below, the Latonia shale is more distinctly blue, often intensely so where fresh. It weathers into a greenish yellow or drab. All the shales of the formation are soft and cal-

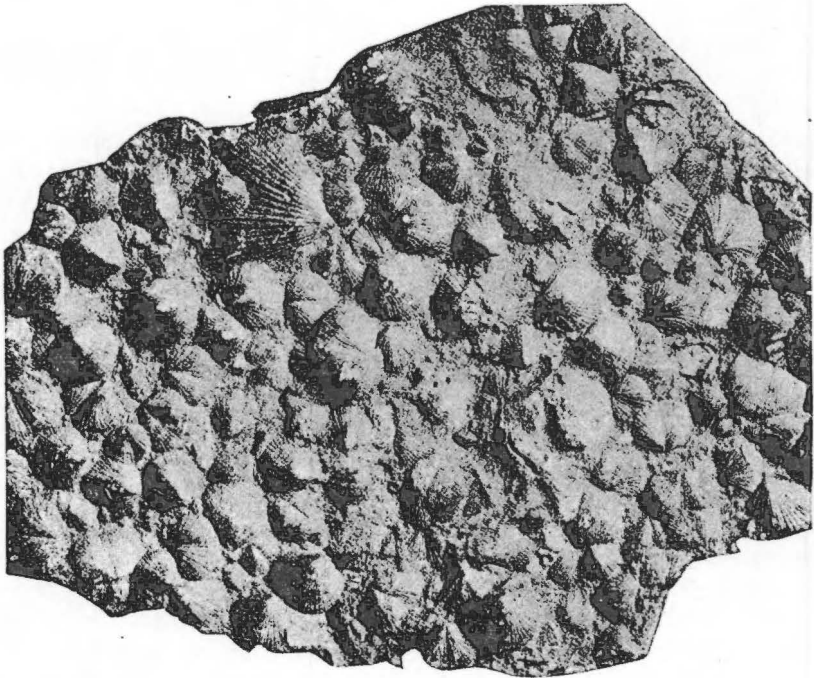

Fig. 28.—Fossiliferous limestone, *Dalmanella Zone*, near top of Eden group. (Chamberlin and Salisbury).

careous; some beds are highly calcareous, almost marly. In others the carbonate of lime has aggregated into ellipsoidal concretions, having the texture and color of very dense blue argillaceous limestone. This feature is well shown on West Fork Creek west of Cumminsville.

**Proportion of Limestone.**—While the Latonia is essentially a shale formation, it contains here and there a bed of limestone.

Of the limestone layers interspersed, most are coarse textured, crystalline, and fossiliferous, but a minority are of a dense granular variety and lacking in fossils. The layman readily sees at different

<sup>1</sup>The name Latonia shale has been adopted by the U. S. Geological Survey for use in the Cincinnati folio.

levels differences in the amount of limestone interbedded with the shale. It is greatest in the upper portion and least in the middle. Near the top, limestone beds reaching a maximum thickness of ten inches may at places constitute as much as one-third of the entire mass. A number of such layers in close proximity may even make a strong ledge two or three feet thick. In the 100 feet nearest the middle of the formation not more than one-sixth to one-tenth is limestone. Locally there may be found sections of twenty to thirty feet with less than a foot of limestone. The lower fifty feet have a larger proportion of limestone, but nowhere enough to cause this formation to be mistaken for others when judged by physical character alone.

**Thickness and Geographic Relations.**—The Latonia formation is thicker north of Cincinnati (maximum 230 feet) than to the south. It thins to 180 feet on the southern border of the Cincinnati quadrangle and gives out entirely in parts of central Kentucky, presumably because land existed there throughout the Eden epoch. But it is known that the sea in this region was not entirely cut off by land to the south, because the fauna shows that there was free communication.

**Topographic Relations of Outcrop.**—All the great valleys in the southern half of this area, and to the south far into Kentucky, cut down into or through the Eden shales, but the adjacent uplands are capped by the stronger limestone formations which overlie the shales. (See Fig. 29, p. 67.) This structural condition has helped to make the beautiful steep bluff slopes which distinguish this area. Without the strong capping of the uplands, the hills near the rivers would have been cut to lower altitudes and gentler slopes. Without the weak shales beneath, the bluffs would be less steep, because the effects of sapping would be absent. Actual exposures of the shale are not numerous, for it is easily weathered and a thin soil formed. The general steepness of the slopes, however, prevents the accumulation of a thick soil. These features are less noticeable in the northern part of the area because of the effects of repeated and recent glaciation. It should also be remembered that the formations dip north while the valleys slope south; hence in going north the limestone on the hills comes nearer and nearer to the valley floor. North of Sharonville in Mill Creek Valley, and Venice in the Miami Valley, the shales lie entirely below the level of the alluvium. Even there, however, sapping was active when the streams ran at lower levels before the valleys were partly filled by glacial outwash.

**Good Exposures Located.**—The best available section of the Eden is in the steep bluff one mile west of Bromley, Ky., and opposite Sedamsville. Here it is more or less exposed from an altitude of sixty feet to 280 feet above low water. In the north bluff of the Ohio, seven miles above the mouth of the Little Miami, is a small stream with steep gradient, in whose rocky bed the lower two-thirds of the Latonia for-

mation are well exposed. The upper two-thirds are exposed by the grading of Elberon and Columbia avenues, Cincinnati. The grading of McMicken Avenue below the Bellevue incline has similarly exposed the upper portion. The same can be well seen from the stairway leading down from Mt. Adams on the south side. In the bed of West Fork Creek west of Cumminsville, the upper two-thirds of the Latonia are well exposed.

**Falls and Rapids.**—The thick beds of soft shale, interrupted by strong beds or ledges of limestone, offer ideal conditions for small waterfalls of the Niagara type. There are many of these along the small streams descending the steep valley sides. Where the stream has a sufficient gradient each individual fall may cover the entire vertical distance between two limestone beds. This is well illustrated on West Fork, from one to three miles west of Cumminsville. (Pl. II-A.)

**Soil Cover.**—Near the Ohio, especially where the drainage is young because of recent changes (pp. 121 to 123), are many steep slopes, crossing almost the full thickness of the Eden shales. These slopes are covered with a thin soil strewn with limestone fragments from the Latonia and higher formations. This is typically illustrated on Dry Creek and its branches south of Andersons Ferry.

On the slopes of Mill Creek Valley, and on other steep slopes near Cincinnati, the underlying Eden shales may be detected by many yellowish drab spots, only partly or poorly covered with vegetation. The color is characteristic of the weathered shales before an admixture of humus has made a true soil.

### *The Maysville Group*

Above the Eden shales, and much exposed in the hillsides near Cincinnati, are about 200 feet of alternating limestone and shale known as the Maysville group. The name is taken from Maysville, Ky., on the Ohio River about seventy miles above Cincinnati, where the beds are typically represented. In southwestern Ohio this group was early called the "Hill Quarry beds" in distinction from the "River Quarry beds" or Cynthiana, the local representative of the Treaton.

**General Character.**—As indicated by the old name, this group is characterized by its limestone beds suitable for quarry rock. The aggregate thickness of these is by no means equal to that of the interbedded shales, but they afford the chief quarries of the region. The shales are soft and calcareous like those of the Eden, and generally blue, though sometimes less blue and more yellowish than those of the Eden. The limestones are blue, generally coarse textured, crystalline, and highly fossiliferous. Individual beds are from two to ten or more inches in thickness, three to six inches being common.

Some of the beds, especially in the lower part of the group, are sandy near the southern border of the area. This sandiness becomes more

prominent where the beds are weathered (often to a reddish color). An occasional bed may almost be called sandstone. This sandy character becomes more marked toward the south. In central Kentucky the lower part of this group (Mount Hope member) becomes a part of the Garrard sandstone.

Differences in character at different levels within the Maysville group are evident to the casual observer. These differences have to do largely with the proportion of limestone to shale, but to some extent also with color and other characteristics. Technically it is divided into two formations, the Fairview below and the McMillan above. These divisions are based on fossils but serve fairly well for descriptive purposes.

#### *Fairview Formation*

Of the 120 feet of limestone and shale which compose the Fairview at Cincinnati, the uppermost fifty feet have more limestone than shale, perhaps twice as much. The remaining seventy feet have these proportions about reversed. Roughly these parts correspond to the Fairmount limestone member above (in which the quarries occur), and the Mount Hope shale member below; but only roughly, for the separation of these members is on faunal, not on physical grounds, and the dividing line is drawn about thirty feet below the base of the closely crowded limestones. The topmost seventy to eighty-five feet (in this area) are assigned to the Fairmount, and the lower fifty (where the member is thickest) to the Mount Hope member.

**The Basal Limestone.**—At the base of the Mount Hope member, marking the contact between Eden and Maysville groups, is an exceptionally heavy bed of limestone, probably the thickest bed in the Cincinnati series. Locally its thickness is more than a foot. It is one of the few beds in the region which can be readily recognized by its fossils without expert knowledge. Its surface is everywhere partly or wholly covered with shells of an easily recognized brachiopod, *Dalmanella multisecta* (Fig. 28, p. 63). Commonly, though not always, the bed including the fossils is reddish or reddish brown. The whole bed is generally composed of fossils and fossil fragments. Beds of similar color and fossils occur in the upper six or eight feet of the Eden shales, sometimes close together, forming a strong ledge. With a little care this horizon may be so learned as to be readily recognized wherever found. It is familiarly known among geologists as the *Dalmanella* zone.

**Thickness and Geographic Relations.**—The Fairview formation (and indeed the whole Maysville group) thins toward the west and to some extent toward the north. At the southeast corner of this area in the bluffs of the Ohio, its thickness is 120 to 125 feet. On the Miami River west of Cincinnati it is only 100 feet. Twenty miles farther west in Indiana it is but seventy to seventy-five feet, and the whole Cincinnati

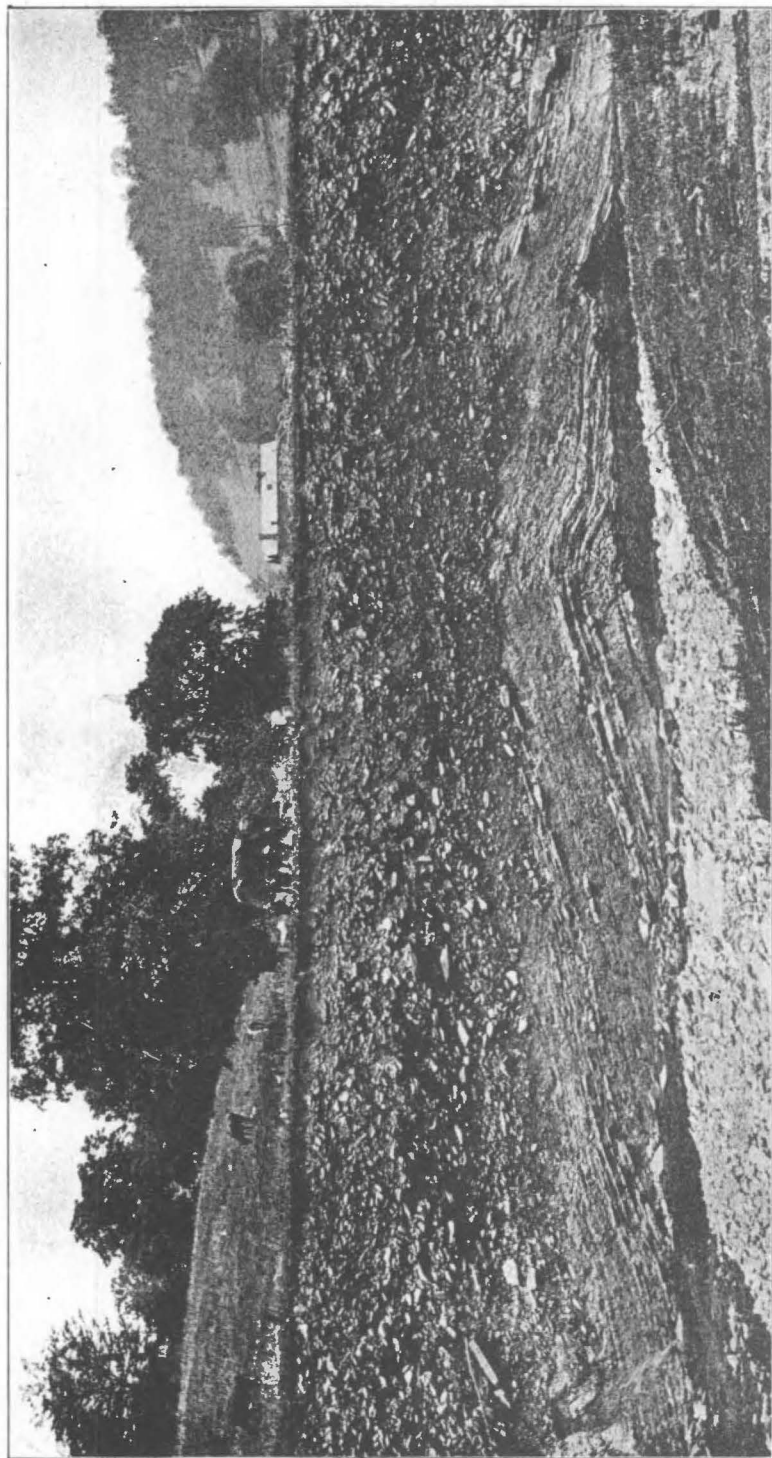

Fold and thrust fault in Eden shale, West Fork, one mile above Cumminsville.

series is believed to pinch out before reaching Illinois. The lower beds pinch out first, indicating that the sea in which this group was deposited began by submergence on the east side and advanced westward by progressive sinking, but Illinois remained above water. The whole Cincinnati area may have been dry land for a time between the Eden and Maysville epochs.

**Topographic Relations of Outcrop.**—In the southern part of the area the Fairview formation generally outcrops in the steep bluffs (Fig. 29). On the uplands it is generally covered by other beds, and generally the exact brow or shoulder of the hill, when such a shoulder is well marked, is caused by a higher formation. In most localities

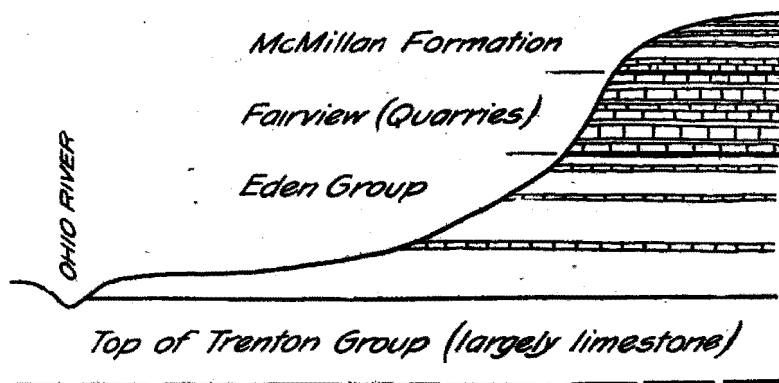

Fig. 29.—Diagram showing topographic effects of the several formations outcropping at Cincinnati. The steepness of the slopes (greatly exaggerated) on each formation corresponds roughly to the proportion of limestone. The Bellevue member at the base of the McMillan caps the bluff more frequently than any other. The limestone beds in the drawing merely suggest the proportion of limestone to shale, but do not show the actual position or number of the beds.

near Cincinnati the horizon of the Fairmount is easily located, not only by the topographic features here described but by the numerous quarries which have been opened in it.

Going northward along the great valleys, not only are quarries less numerous, but, as the limestone approaches the valley floor, the sapping, due to the weakness of the underlying Eden shales, becomes less and less prominent, and the bluffs are less abrupt except where recently undercut by streams. Hence, in the vicinity of Hamilton the outcrops of the several formations are not reflected in the topography to the same extent as near Cincinnati. (For description of the valley forms see p. 31.) Toward the north also, the Fairview in the uplands becomes more and more deeply covered by later formations.

**Good Exposures Located.**—Good sections of the formations may be studied in the steep bluff one mile west of Bromley, Ky., also along Clifton Ave., Cincinnati, below the Bellevue Incline, and in the quarries

bordering Mill Creek-Valley on both sides. The quarries west of the Miami River at Hamilton are in the same formation as those at Cincinnati. The Mount Hope member is perhaps best studied in the slope of the bluff known by that name southeast of Price Hill. Its thickness here is not over forty feet, having decreased from fifty on the Licking River. In the gorge of the West Fork of Mill Creek, one and one-half miles southwest of Glendale, the whole Mount Hope member is well shown, being but sixteen feet thick at that place.

### *McMillan Formation*

**Bellevue Limestone Member.**—Those who are familiar with the quarries in the Fairmount formation will have observed just above most of them a strong ledge of rock fifteen or twenty feet thick, which generally stands out in a distinct angle or shoulder in the natural slope of the hill. This ledge is the Bellevue, the basal member of the McMillan formation. Its strength and prominence are due chiefly to its large proportion of limestone, but despite this fact it is not used as quarry rock. Its layers are irregular and thinner than those below. The lower three-fourths of the Bellevue is almost a solid mass of bryozoa. Many of these resemble branching corals and are frequently mistaken for them. At the top there is generally a bed often several feet thick, consisting almost wholly of single valves of a thin shelled brachiopod.

As an indication of the exceeding abundance of marine life during the time that the Cincinnati rocks were being deposited, these beds have no superior. The sea was necessarily shallow, light, and warm, and food was abundant. That it was also clear is indicated by the fact that there was very little sediment except the hard parts of the animals themselves. The conditions were similar to what may now be found on parts of the continental shelf near Florida where the dredge brings up nothing but broken shells. In some such localities the abundance of life is said to exceed that of any tropical jungle. A fact of equal interest in the Bellevue beds is the sudden change from a colony of bryozoans to one of brachiopods. The exact reasons for such changes are not explained but they are not uncommon. Something in the temperature, the character of the water, the food supply, or the presence of enemies which fed on such animals, may have caused the change; or the mere migration of one type may have been sufficient to displace the other.

Fragments of the Bellevue beds are found frequently in the refuse of the quarries. Its technical name *Bellevue* is taken from the former Bellevue hotel which stood at the top of the incline used by the Clifton-Elm cars. At this point, within the bend of Clifton Avenue, these beds stand out boldly, and make the brow of the hill. Its association

with the quarries, its peculiar physical character, and its habit of forming the brow of steep slopes have made it one of the best known members of the Cincinnati series.

**Corryville Shale Member.**—The forty or fifty feet of beds next above the Bellevue attract much less attention. Their limestone beds are relatively few and thin. Shale constitutes the larger part of this member, hence it wears down readily into gentle slopes which become covered with vegetation. The name Corryville is taken from that part of Cincinnati which lies east of Burnet Woods Park. In that part of the city it covers the Bellevue on most of the hills and uplands.

**Mount Auburn Concretionary Shale Member.**—Still higher on the hilltops are remnants of another member, well known to youthful collectors of fossils. It is the Mount Auburn member, generally not more than twenty feet thick and consisting mainly of blue shales. But in these shales are irregular beds and nodules of limestone, causing exposed surfaces to be rough and scraggy, the individual beds being poorly distinguished. It is in these beds that the well known massive brachiopod *Platystrophia lynx* is found, better known among young collectors as the double-headed dutchman. This member is represented only on the higher hills like Mount Auburn and Clifton Heights, and generally only in small patches.

### *The Richmond Group*

**General Character.**—The foregoing descriptions complete the list of formations exposed in the immediate vicinity of Cincinnati, except for the ridge extending north from Westwood. Those who know the hillsides and streams a little farther north in the vicinity of Lebanon or of Oxford have encountered certain familiar forms which are unknown in the quarries and streams near Cincinnati or even Hamilton. Among these the most familiar are probably the large solitary corals having about the shape and size of "calves' horns." The presence of these indicates a higher group of rocks known as the Richmond. This higher group has been almost completely stripped by erosion from the vicinity of Cincinnati, but outcrops in a broad band thirty to fifty miles from that center where the uplift was less. Its lower formations cover considerable areas in the Hamilton and Mason quadrangles. The group as a whole is fairly well represented in the northwest corner near Oxford where it caps the higher uplands. The name of the group is taken from Richmond, Ind., where it is well exposed, and has been thoroughly studied. Where well developed it is about 300 feet thick.

Most of the Richmond is even-bedded, with clean cut alternations of limestone and shale, in this respect strongly resembling the Maysville. The limestone beds vary in thickness from two to ten inches (generally less than six inches) and comprise less than half of the whole mass,



perhaps not more than one-fourth. On the whole the color of its limestones is less blue and more gray or dove colored than that of the Maysville. But these physical distinctions are relatively unimportant and not sufficiently uniform to be trustworthy for purposes of identification. The real and essential distinction is in the fossils. These show that the sea was inhabited by a very different fauna during the Richmond epoch from that which lived in the previous epochs. The advent of corals is only one of the many changes.

**Formations.**—The lowest formation in the Richmond group is the Arnheim shale. It rests on the Mount Auburn and is about eighty feet thick. It consists largely of dark bluish shale with a subordinate amount of blue limestone. In part it is even-bedded like most of the lower formations, but it has other portions, especially near the top, which look like the Mount Auburn. In these the limestone occurs in rough irregular beds or nodules with scraggy masses of indurated clay, strongly contrasted with the regular bedding above and below.

The next fifty feet of the Richmond is called Waynesville shale. To a casual view it is not unlike most of the other formations, but at many places its gray or dove colored limestone, associated with strikingly blue or greenish-blue shales, gives something of distinction to its appearance. Its shales are sometimes highly calcareous or marly. It is well exposed near Oxford. Above the Waynesville are thirty-five feet of beds, known as the Liberty limestone, which differ little from the Waynesville except in fossils, though the limestone layers are more abundant and bluer. All that lies above the Liberty in this area is included in the Whitewater formation. The physical characteristics of this are not unlike those of the Mount Auburn beds of the Maysville (page 69). It lacks the clean-cut even bedding of the formations immediately below it. Both its limestones and shales have a rough concretionary or nodular appearance. While blue in places, the color is more generally brownish or yellowish. Much of the limestone is very impure.

## CHAPTER IV

# PRINCIPLES PERTAINING TO CHANGES NOW IN PROGRESS

The processes by which land forms are made and continually changed are well illustrated by many phenomena within the area here described. The general principles underlying these may be conveniently discussed under three general heads: (1) Weathering or the breaking down of rocks, (2) Transportation or the movement of disintegrated rock, generally through the agency of water, and (3) Deposition, or the laying down of mud, sand, and gravel, generally after transportation for a considerable distance.

### WEATHERING OR THE BREAKING DOWN OF ROCKS

Solid rocks are wasted away by a variety of processes. Some of these merely break up the ledge or stratum into large pieces, and these again into smaller fragments without changing their nature or constitution, so that in the end each fragment is, in all its properties, identical with the original ledge. Such changes are purely physical and, at most, only *disintegrate* the rock, but do not *decompose* it. Other agencies actually decompose the rock, changing its chemical constitution as well as destroying its integrity. Some rocks are more affected by the purely physical agencies of disintegration, others yield more to the chemical agencies of decomposition. If a rock is composed of two or more kinds of minerals thoroughly intermixed, as in case of granite (p. 37), the decomposition of the one mineral may cause the entire rock to disintegrate. While the several agencies of weathering may readily be distinguished and discussed separately, the actual process which causes the disintegration of any one rock may be, and usually is, complex.

#### *Solution and Chemical Changes*

Some rocks, like salt, are readily dissolved in water. Others, like limestone, are dissolved slowly by ordinary terrestrial waters after a slight chemical change. This process is well illustrated in this area. Its results are seen on an exceptionally large scale in the cave region of Kentucky.

**Passages Made by Solution.**—One of the striking features of the

limestones of this region is the occasional presence of grooves or tubes in the surface of the bed. (See Pl. IV-B, and Fig. 30). These grooves may be as large as a lead pencil or larger than a man's arm. They wind and curve in serpentine forms and are so long that a single slab of limestone generally shows nothing of how they begin or end. Such grooves started by the slow trickling of water between the closely fitting beds. Where well formed they are always on the under side of limestone beds, because the intervening shales are more impervious than the limestones. The latter are more or less cracked or jointed. Through such openings the water descends, but is stopped by the soft dense shale which does not crack. The water therefore trickles along

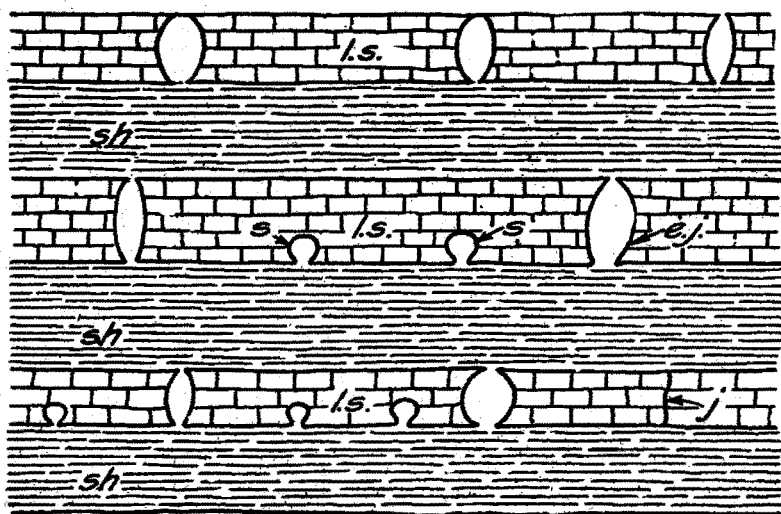

Fig. 30.—Diagram showing cross section of interbedded limestone and shale with solution channels in the limestone. *Sh*—shale; *l. s.*—limestone; *j*—joint; *e. j.*—joints enlarged by solution; *s*—solution channels in limestone

between the limestone above and the shale below. It can dissolve the former but not the latter. Hence it enlarges its passage upward. As the groove is enlarged, the slow trickling may give way to a flow at a considerable rate.

In a similar way many of the joints are enlarged. It is noticeable in many quarries, especially near the surface, that the blocks which compose any one bed do not fit closely but may be separated a few inches. The edges of the blocks are frequently concave, thus making the passage more or less tubular (Fig. 30).

**Caves and Limestone Sinks.**—The process above described, when carried further, results in caves. Most caves have this origin and are therefore in limestones. Such caves are, therefore, not primarily rooms but passages. The stream which is usually present is, therefore,



A.—Limestone sinks at the edge of the Covington, Ky., City Park. (See p. 72.)

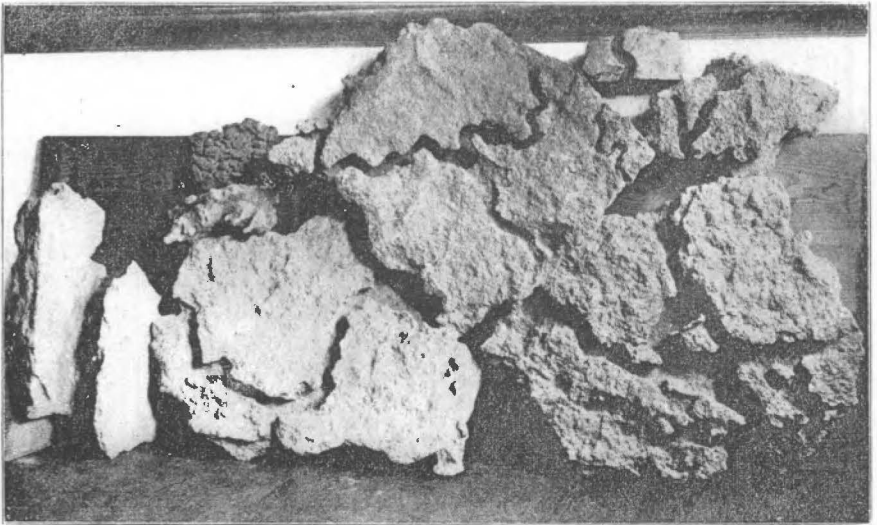

B.—Solution grooves in limestone. The view shows the lower surface of the slabs. (See p. 71 and Fig. 30, p. 72.) (Photo by Bridge.)

not an accident or a mere incident, but may almost be said to be the cause of the cave. If the limestone were 100 per cent pure it would all dissolve, and the cave stream would carry no mud or sand except such as might fall through the roof. In such a case the cave would be due almost wholly to solution. Ordinary limestone, when dissolved, leaves a residuum of mud which gives to the water a rasping effect. Where the limestone contains flints or chert nodules, these, being insoluble, accumulate as gravel in the bed of the cave stream, thus making its wearing effect much greater.

Limestone sinks, or "sinkholes" are caused by the dissolving action of water descending from the surface through joints or cracks to some kind of passage below. Sometimes this passage is a large cave, but it should not be inferred that a sinkhole always, or even generally, indicates the existence of a cave below. A few typical limestone sinks are found in Burnet Woods Park and the campus of the University of Cincinnati. Excellent examples are seen near the eastern border of the Covington City Park (Pl. IV-A). Others are found on the upland near Licking River, six or seven miles south of Covington. A small area which is pitted to a remarkable degree with such holes is found in the northern part of section 17, Sycamore Township, about midway between Hazelwood and Sharonville.

Very large sinks are sometimes made by the falling in of the roof of a cave, but this region, containing no caves worthy of the name, does not afford examples of this type of sink. Where the cave or passage below a sink, or the passage leading downward to it, is stopped, lakes or ponds result. This is the case with one of the sinks shown in plate IV-A. Where sinkholes are numerous they receive all the water falling on the surface, and continuous surface streams are not found.

**Other Chemical Changes.**—Aside from the processes involved in the solution of limestone, the only chemical process much in evidence is oxidation. The oxygen of the air in the presence of the moisture of the earth affects even the limestones. The effect may be seen in any quarry or ledge. The rock is weakened, and its lively blue color is changed to a dull yellow. The substance thus sought by the oxygen is iron, and the yellowish color of the weathered rock is due to iron oxide (iron rust). Slabs taken from near the surface in this area frequently have a blue center surrounded by a yellow border, indicating the presence of iron oxide. There is no more iron in the border than in the center, but it is not noticeable as a coloring matter until fully oxidized. Many of the rocks of the glacial drift (p. 107) contain far more iron than the limestone, and are consequently more subject to oxidation. In many cases their color is completely changed and their coherence entirely lost.

A very important agent in decomposing the minerals of igneous rocks is carbonic acid, a gas which animals exhale from their lungs and

which results abundantly from decaying vegetation. The work of this agent is called *carbonation* and is quite as important as oxidation, but, unlike the latter, it is not apparent to the casual observer. It helps to decompose most of the igneous rocks such as the granite and other foreign boulders of our glacial drift. The decomposition and disintegration of these yield sand and clay as shown on page 41. Moreover, if carbonic acid gas were not contained in ordinary surface waters and ground water, they could dissolve very little limestone, so little that there would be almost no caves and but very little limestone soil.

### *Mechanical Changes*

**Frost.**—Of the agencies which merely break the rock to pieces but do not change its nature, the most prominent in this region is "frost," or, more properly, frozen ground water.

Water, on freezing, expands one-eleventh of its volume. The force of this expansion is about one ton to every square inch. Hence any crack in rock, if filled with water, will get larger and larger with every freeze. Ultimately the strongest rock must be ruptured if its minute cracks are allowed to fill with water in this climate. The effects of frost are seen at the foot of every steep rock face. Wherever grading for railroads, roads, or other purposes, has made a steep rock face, or wherever an old quarry has been abandoned and its steep face left to the forces of nature, frost has pried loose fragments of the rock, and these have accumulated as a *talus* at the foot of the cliff. Railroads which run at the foot of steep rocky slopes, like the Chesapeake & Ohio opposite the mouth of the Little Miami, encounter danger from such falling blocks in the freezing season.

The work of freezing water is not limited to steep bluffs, though its effects there are more spectacular than elsewhere. Everywhere, as deep as the "ground freezes," the effect of freezing in cracks and pores is to rupture the rock and to open the way for the agents which act chemically. Nor is the work of frost restricted to fresh and solid rocks. It continues with equal importance in weathered or "rotten" rocks and even in soil.

**Heat and Cold.**—Another agent which helps to open cracks is the sun's heat. By causing expansion during the day and in summer, associated with contraction at night and in winter, it is an effective agent, but its effects in this region are not so evident as are those of freezing. It co-operates with frost in the wasting of cliffs and the making of talus. Its effects are often seen in the cracking and bulging upward of concrete sidewalks on a hot summer day. Rocks are broken by this agency as a glass dish or jar is broken by hot water, that is, by the expansion or contraction of one part without the remainder, or of the surface without the interior. For this purpose the heating or

cooling must be relatively sudden. This agency is more important in deserts where the contrast between day and night temperatures is greater than here, and where heating and cooling are more sudden.

**Plants.**—The work of roots in helping to break up rocks is manifest at many places on the bluffs where trees grow with little or no soil, their roots entering crevices in the rock, which are slowly widened as the roots grow. It may, however, be said of this agency as of many others, that its more spectacular effects are not its most important work. For every block of rock actually pried off by the expanding root of a tree, a thousand crevices are slightly widened so as to admit more freely the agents of chemical decomposition. Again, the work of tree roots which challenge our notice, is probably small as compared with that of humbler forms of plant life like lichens. Wherever the face of a rock is blotched with green or gray patches, the minute rootlets of lichens are engaged in a work whose aggregate effect greatly exceeds that of tree roots. In still further contrasting the more noticeable effects with those which escape popular notice, it might doubtless be shown that the aggregate of all the mechanical effects of growing plants is small in comparison with the chemical effects due to the products of their decay, especially to carbonic acid.

**Sapping.**—An important factor in the breaking up of rocks is the indirect effect of the disintegration of their neighbors. Where the edges of nearly horizontal beds are exposed, and one of the lower beds is easily worn or weathered away, the effect is to withdraw support from the stronger rocks above, which then break off in a vertical face. This process is called sapping. It is very important in the weathering and wasting of all the cliffs in this region. All consist of limestone interbedded with shale, the former strong, the latter weak. It has already been shown how frost breaks off blocks of limestone, but this process is greatly helped by the fact that the shale beneath each limestone bed weathers and wastes away continually. Thus the strong bed above is left *overhanging*. Ultimately it would break off of its own weight, even without frost. The weathering of the shale itself is partly by alternate freezing and thawing; partly by alternate wetting and drying; partly by dissolving certain constituents. Vegetation and wind also help.

In a large way this principle of sapping is accountable for some of the steepness of the bluffs in the southern half of this area. It is shown on page 67 that the upper half of these bluffs consists of stronger formations than the lower half. The latter is largely of shale which wastes rapidly.

#### *Movements of Rock Waste*

All the processes described above, which break down rocks, tend to bring them into suitable condition to be transported. In fact, the

whole complex process of weathering may be viewed from a physiographic standpoint as merely preparation for transportation. This latter process, like the former, is effected chiefly through the agency of water, though to a less extent by wind, and in a slow way by gravity without the immediate aid of either water or wind.

The word erosion, which has come to be used in a somewhat general sense, may be taken to include all processes whose effect is to pick up and remove surface materials. It is frequently, though not uniformly, used in more restricted senses. Probably the word is now too familiar to be pressed again into a narrow technical sense. As generally understood, it includes corrasion. (See p. 80). This is the process by which a stream wears away its bed, often working on fresh rocks, that is, without previous weathering. Erosion also includes the widespread wash by surface waters before concentrating into streams or even into rills. (See p. 77). In a very general way it even includes *creep* (see below), as when mountains are said to be carved and reduced in height by erosion. The terms creep, unconcentrated wash, and corrasion are specific and definite, and should be used instead of the general word "erosion" wherever the manner of removing material is to be specified.

#### *Creep*

A quiet process, attracting little attention but omni-present on slopes, is the slow creep of disintegrated rock and soil under the influence of gravity. The steady and uniform pull of this force would not of itself set the mantle rock in motion, but during any slight disturbance or rearrangement of particles a majority of them come to rest a little down hill from their former position. Such rearrangements result from such alternating processes as freezing and thawing, warming and cooling, wetting and drying, or from the creeping of worms and the movement of roots as the trees above sway in the wind. Nothing in the process attracts attention, but its results are so common that a landscape of steep slopes would look strange without them. Among these effects is the tendency of trees to lean down hill, a phenomenon so nearly universal that it is not fully realized until a picture is seen in which the trees along a ravine are made to stand vertically. The ground near the surface, being most subject to such mild agitation, moves most rapidly, carrying with it the base of the trunk, while at greater depths the roots retain almost their original position. Thus a rude measure of the velocity of creep is afforded by the degree to which trees lean down hill.

Since phenomena like this are as widespread as steep slopes, individual examples need not be cited, but they are found in special abundance and beauty on the steep slopes of the Ohio and Miami bluffs and in the ravines which indent them. The character of the surface



formations and soil in this region is especially favorable to creep. Sometimes in the winter or spring when the ground is unusually full of water, the movement is so accelerated that large cracks are opened. Pavements, fences, and walls may be badly displaced. Such instances are sometimes loosely called *landslides*, and they do indeed grade into true landslides in which a portion of the hillside falls suddenly into the valley. The word *slump* is a less definite term, often applied to such displacements regardless of the rate of movement.

### *Unconcentrated Wash*

The wash by surface waters, before concentrating into separate streams, differs from creep in affecting surface particles only. Like the latter it is intermittent, though its periods of activity differ from those of creep. It is like the latter in its quietness and liability to escape notice, as well as in the greatness of its effects. Water thus moving is not to be thought of as a sheet of uniform thickness, but rather as a great web or net of small rills which are not constant in position, and none of which pursues its course very far without further subdivision or union with others. Even where grass is absent these rills do not cut channels, because their small power is all used in transporting the sediment with which they are loaded.

Among the familiar effects of such unconcentrated wash is the filling on the uphill side of obstacles such as buildings, bowlders, and (in regions where they exist) stone fences. The effect on a plowed field after a rain is often seen in the filling of small depressions, leaving in their place flat surfaces covered with a web-like pattern of rill marks.

Such rills, whose work is classed as unconcentrated wash, bring to the streams a large part of the mud which great streams like the Ohio and Mississippi carry in such enormous quantities. The exact topographic effect of such wash is not easily stated, but without it the shapes of valleys, especially their borders and heads, would differ greatly from the forms which are familiar.

### *Transportation in Solution*

It was seen above that the weathering away of limestone is accomplished largely by dissolving it. Much of this and of many other substances is thus transported to the sea. Most waters from rivers and wells in northern United States are known as "hard." This is because of mineral matter (chiefly calcium carbonate, the substance of limestone) in solution. The Ohio is not a "hard" stream as compared with others. Out of every million pounds of its water passing Cincinnati, 120 pounds are mineral matter in solution. This means that each minute twenty-six tons of dissolved mineral matter pass by Cincinnati

on their way to the sea, a total of 13,683,600 tons per year. In a similar way the Miami delivers to the Ohio more than two tons of mineral matter in solution every minute.\* In proportion to its volume the Miami carries a much larger load in solution than the Ohio.

While on the one hand this process implies a great wasting of limestone and other soluble rocks, it is, on the other hand, supplying the sea with the material from which new limestone is being made. The material now in solution becomes solid again when taken by animals to build their shells. From the remains of these organisms new limestone is made.

### *Transportation in Suspension*

A second way in which the waste of rocks is transported to the sea is by carrying it in suspension. In this condition the individual particles of sediment are very small and remain suspended in the water as mud. Each particle is constantly being drawn downward by gravity and would ultimately settle if the water were at rest, but by the constant commotion of the water it is repeatedly carried upward.

**Sand-Boils.**—From any bridge over the Ohio, when the water is not too low, or better still from the deck of a steamer, the upward currents of the water may readily be seen making the so-called "sand-boils" or "mud-boils." These are nearly circular patches from a few feet to a few yards in diameter within which the water is evidently rising, carrying upward so much sediment that, in contrast with the surrounding water, these "boils" are distinctly brown. Such localized upward currents, and others which cannot be detected by any surface phenomena, may keep a single particle of mud in suspension continuously from Cincinnati to the Gulf of Mexico. More often, however, one particle probably comes to rest many times within that distance, and may rest at some places for years or even centuries.

**Contrast of Streams.**—Rivers differ greatly in the amount of mud carried in suspension and in the ratio which such load bears to that which is carried in solution. Thus the Ohio which carries 120 parts per million in solution, carries 230 parts per million in suspension. The major part of its load is therefore mud. On the other hand the Miami at Dayton carries 289 parts per million in solution and only ninety-four parts in suspension. Its water is therefore almost two and one-half times as "hard" as Ohio River water, while the latter is almost two and one-half times as muddy as the Miami. Thus the Miami is seen to carry its load chiefly in solution. Even the Ohio is not a muddy stream. As compared with Missouri River at Kansas City the latter is more than three and one-half times as hard and about

---

\*Computed from data in U. S. Geological Survey Water-Supply Paper No. 234 pp. 88 and 89. The data of the following paragraph are taken from the same source.

nine times as muddy. This stream contributes most of the mud to the Upper Mississippi. After the union of this stream with the Ohio at Cairo, Ill., the waters of the two streams may often be distinguished for many miles, each flowing on its own side of the channel, the waters of the Ohio being light yellow as compared with the darker yellow or brown waters of the Mississippi.

### *Transportation on the Bottom*

All that portion of a river's sediment which is composed of particles too large to be held in suspension, is rolled or pushed along the bottom, or carried forward by a process called saltation, in which the stones bound along very much as a baseball bounds along the ground, touching it at frequent intervals. The whole complex process of carrying material along the bottom has been aptly called by Gilbert, *stream traction*.

**Effect of Velocity.**—While, in supporting sediment in suspension, agitation is the chief requisite, the onward velocity of the water at the bottom is of prime importance in transporting sediment on the bed of the stream. It has been found out by experiment that a current of two miles an hour is able to roll or push over its bed fairly rounded stones having an average diameter of one and one-half inches. Since the velocity of streams at the bottom is much less than at the surface, the Ohio and Miami do not at ordinary stages flow two miles an hour at the bottom. In moderate floods, however, their bottom velocities reach that amount, and in great floods it becomes much larger. It is a principle of physics that the energy of a moving body varies as the square of its velocity, hence doubling the velocity causes the water to strike four times as hard. This enables it to move stones whose diameter is four times as large. In volume and weight such stones are therefore  $4 \times 4 \times 4$ , or sixty-four times as great as those which were moved by the water flowing two miles an hour. If the velocity be trebled the water would strike nine times as hard, and the size of the stones capable of being moved would be  $9 \times 9 \times 9$  or 729 times that of the stones moved at first.

The greatest stream velocities are not found in our large rivers, but in their smaller tributaries like those which traverse the bluffs of this region. These not only have steep profiles but have much smaller depth than the main streams; hence large boulders which are barely immersed receive the full force of the current. It need not therefore cause surprise to note that from time to time huge boulders are carried down our smaller streams. As transportation by rolling and pushing is almost restricted to times of flood, and the water is also much muddier at such times, it may fairly be said that streams do nine-tenths of their

<sup>1</sup>For exact data see Gilbert, G. K.—The Transportation of Debris by Running Water. U. S. Geol. Surv. Prof. Pap. No. 86, p. 216. 1914.

work in one-tenth of the time. This is a conservative statement. Some streams, especially intermittent ones, may do ninety-nine per cent of their work in one per cent of the time.

**The Scouring of Channels.**—The material which is urged along the bottom of the Ohio and Miami at ordinary stages is chiefly sand, and that is carried but sparingly. In great floods, however, the underlying sand and gravel may be scoured out to great depths. During the great flood of March-April, 1913, the Whitewater scoured its channel to a great depth, possibly thirty or forty feet at the Big Four railroad bridge one-half mile above its mouth. Such local scouring may be intensified by the presence of piers which hinder lateral cutting and create eddies in the current, but there is other evidence to show that streams frequently make such local excavations during floods. The habits of the Missouri at Omaha have been studied with some care and the conclusion reached that its local scouring frequently extends to great depths, occasionally to more than seventy feet.<sup>1</sup> In building bridges over the Mississippi, where forty to fifty feet of gravel intervene between the river's bed and the limestone below, the surface of the latter has, in more than one instance, been found polished and perfectly fresh, instead of rough and weathered as it should be if the gravel rested on it unmoved for many centuries.

Opposite Cincinnati there are thirty to fifty feet of sand and gravel between the river's bed and the solid rock beneath. Observations have not been made with reference to scour, but it is probable that much of this material is periodically scoured out and carried some distance down stream. The bed rock surface is not everywhere equally deep beneath the Ohio channel. Wherever it lies relatively near the surface it is probably worn down at intervals when the sand and gravel are locally stripped away. How deep this scouring extends it is not now possible to say, but it is possible that the deepening of the rock trough is thus going on at intervals throughout that portion of the Ohio which is included in the area here discussed.

The Miami throughout this area runs several hundred feet above bed rock. (See p. 148). Its ability to scour out sand and gravel was demonstrated in the flood of 1913, when it cut out gorges twenty feet deep on its flood plain outside the proper limits of its channel.

#### *Vertical Corrasion*

Corrasion is the technical name for the wearing effect which a stream has on its channel. In so far as it affects hard rocks, it is due largely to the rasping effect of the mud and sand carried by the stream.

<sup>1</sup>Todd, J. E.—The Moraines of southeastern South Dakota and their attendant deposits. U. S. Geol. Surv. Bul. 158, p. 150. 1899.

If a stream has more power than necessary to transport its load, all will move forward with the water; the mud in suspension, at the same rate as the water; the sand and stones on the bottom at a slower rate. Both will corrade the bottom, loosening new material and thus increasing the load to be carried. Thus an excess of power not needed to transport the load, is spent in corrasion. Looked at in another way, the stream always tends to *load itself* up to the limit of its carrying power. The chief cutting by such streams is on the bottom of the channel. They are said to *degrade* their channels; that is, they are *degrading* streams. The effect of deepening is to make valleys steep and relatively narrow (Fig. 31, p. 85). Excess of power and steepness of sides are characteristic of the smaller valleys in the bluffs and to a large extent throughout the uplands of this region.

### *Lateral Corrasion*

As corrasion embraces all the wearing effects of a stream on its channel, it includes that done on the banks. Such lateral cutting does not imply that a stream has power to spare after transporting its entire load. On the contrary, while it is observed to some extent in streams having excess power, it is most noticeable in streams whose load is so great as to prevent down-cutting. Such streams are apt to build deposits which turn the current somewhat against the banks. The effect of cutting away the banks is to embarrass the stream with a still greater load and to require more deposit. Thus a stream engaged in lateral corrasion works its drift over and over, picking up and laying down the same material many times before its final deposition in a delta or elsewhere. In some streams the picking up process is in excess; in others the laying down process.

This process of lateral corrasion is intimately associated with meandering (p. 89). All bluffs which rise from the bottom lands are made by this process. Their steepness is due to cutting at the base when the channel of the stream was there.

### DEPOSITION OF SEDIMENTS

In making the features which characterize this region, the depositional work of the streams is almost as important as their erosional work. Deposition is always associated with some loss of power. This may result from an actual loss of a part of the stream's water, as illustrated by many streams in the arid west which lose volume by excessive evaporation. Loss of power within this area is almost always due to loss of velocity, which may be brought about in many ways. Streams which deposit in their channels more material than they remove are said to *aggrade* their channels, and are spoken of as *aggrading* streams.

*Terminal Deposits*

**Alluvial Fans.**—One of the most common conditions under which a stream loses velocity is a change of slope. In descending a steep slope the stream uses power not needed for transportation, in corradng its channel and thus adding to its load. When it emerges upon a gentler slope its velocity and power are in part lost, and it must deposit a part of its load. This loss of velocity is due in part to loss of slope, and in part to the fact that it spreads out after emerging from the deep narrow channel which it cut where its power was excessive. In either case power is lost and the stream drops material in its channel. When the channel has been partly or wholly filled, the stream is still further spread, with a corresponding further loss of power. The result of aggrading its channel above the adjacent land is that the stream breaks over and takes a new course or subdivides, until, in the course of time, it has flowed over and aggraded the slope in all possible directions from the mouth of the ravine. The topographic form thus constructed is called the *alluvial fan*.

The conditions here described are met in hundreds of short narrow gully-like valleys throughout the area considered. The circumstances are especially typical in the ravines which indent the Ohio and Miami bluffs. The little and often temporary streams in such ravines have abundant power, and thus cut the narrow valleys whose sides frequently increase in steepness from the top down to the stream. On emerging from the bluff upon the gently sloping flood plain, material is dropped in the form of alluvial fans or sectors of low cones sloping in all available directions from the apex in the mouth of the ravine where deposition begins.

Sometimes such fans or cones are found singly, and are so well defined that the material of any one structure may be shown to be approximately equal in volume to that of the gully or ravine from which it was eroded. Often, however, such gullies are so close together that their attendant fans have not room to develop independently. When they are closely crowded, their lateral slopes may be lost, but the inclination outward from the hills is preserved, forming an inclined plane with a slope intermediate in steepness between the abrupt bluffs on one side and the flat flood-plain on the other. Such a feature has appropriately been called an *alluvial slope*.

**Deltas.**—Deposition also occurs where streams discharge into bodies of standing water or into more slowly flowing streams. The topographic form thus produced is the delta. This is not exemplified in a large way within the area studied. Temporary deltas of perfect form are sometimes made in the quieter parts of the large streams.

### *Deposits Inside of Meander Curves*

Probably the most abundant of all stream deposits are those made in the relatively quiet water on the bottom and banks on the inner or concave side of meander curves. These are made at all times and are independent of overflow. The rate of their making is, however, greatly accelerated by moderate floods such as approximately fill the channel. The material laid down is that which is being urged along the bottom. It consists in general of sand and gravel. These are built into a shoal, sloping streamward. Successive additions are put down in rude layers or strata whose dip is that of the surface slope (Fig. 35, p. 91). The height of these deposits is that of the water surface so long as the stream remains within its banks. As the channel is shifted by lateral corrasion toward the convex side of the curve, this deposit of sand and gravel is broadened on the opposite side.

In the way here described, the entire area over which the channel is shifted comes to be covered with a deposit whose origin is independent of overflow. In the case of most streams which have floods, this deposit is covered by successive layers of mud, laid down during overflow as described above.

### *Deposits Made During Subsidence of Floods*

In the two cases considered above, the change of carrying power is between one place and another and deposition is correspondingly local. During the subsidence of a flood, power is lost throughout the entire stream and deposition is correspondingly general. In the one case the variation is from *place to place* and the deposit is local; in the other case the variation is from *time to time* and the deposit is temporary.

**Deposits from Suspension.**—Deposition during subsidence of floods involves both material carried in suspension and sediments pushed along the bottom. The former is deposited as a fairly uniform sheet of mud over the area overflowed, but not within the channel into which the diminished stream retires. The great flood-plains in this region are in part composed of mud or silt laid down in this way. This is, of course, especially true of their superficial layers. At almost any place where great rivers are cutting into their banks a passenger on the deck of a steamer may easily see that the upper five to ten feet of alluvium is prevailingly silt in contrast with the lower layers which consist more largely of sand and gravel.

**Deposits at Bottom of Channels.**—When the flood subsides and the velocity is reduced, much of the material moved along the bottom comes to rest. Sedimentation of this kind affects not only the regular channel but the temporary channels through which the river may flow over its alluvial plain. Sheets of mud deposited from suspension are, therefore,

often traversed by a network of gravel bands. Where the flood plains are built mainly by overflow, and therefore of silt, such webs of gravel may be found at all elevations throughout the deposit, even though it be hundreds of feet thick. The deposit of gravel in this manner was strikingly illustrated by the Miami flood in 1913.

It has been pointed out above that the Ohio during flood may scour its channel to great depths. (See p. 80). The depth of deposit at such places during subsidence is correspondingly great. The fact, therefore, that a stream at ordinary stages runs over a deposit of sand and gravel, is not to be interpreted as showing that the stream is aggrading, or that it is failing to deepen its trough by corrasion.

### THE MAKING OF VALLEYS

#### *Consequent Streams and Valleys*

In considering the origin of valleys, two widely different and sharply contrasted sets of conditions present themselves. The first is that of an accumulated volume of water seeking an outlet to the sea by the lowest possible route. Such a route would be determined by selection from the source downward, and the valley which would later be eroded along that route would be the natural consequence of slopes which were there before the stream, and were simply found by the stream while hunting the lowest possible course. Such valleys and streams are, therefore, spoken of as *consequent*. The Niagara and St. Lawrence rivers which simply followed up the retreating glacier as it slowly melted back toward the north, are good examples. Parts of the Missouri and Ohio rivers, which were crowded southward to their present positions by the continental ice cap, and parts of the Mississippi displaced by the same means, are of the same class. The Potomac and James, which once entered the sea at Washington and Richmond, simply extended their courses seaward as the continent lifted, and the marginal sea bottom became the coastal plain. In doing so they simply followed the slopes which they found, and are, therefore, in their lower courses, consequent streams.

#### *Subsequent Streams and Valleys*

**Origin.**—In contrast with streams and valleys of the above type are those which begin at the lower end and grow headward. Streams and valleys of this kind are subsequent.<sup>1</sup> They start as gullies. In

<sup>1</sup>The term "subsequent" is frequently restricted by American writers to those whose position and growth are determined by softer rocks. Some excellent writers (Geike and others) have, however, used the word in the broader sense. This seems eminently desirable as it affords a suitable comprehensive term in contrast to "consequent."



this case the initial condition of drainage is one of unconcentrated wash. Somewhere on the slope so washed (it may be near the foot), the concentration of water becomes sufficient to cut out a gully. This gully at first carries nothing but storm waters and hence has an intermittent stream. Repeated rains, however, cut it down to the surface of ground water, and when its channel indents that surface there is constant flow. (See p. 171.)

The contrast between consequent and subsequent streams may then be expressed as follows: (1) Consequent streams find their courses laid out for them by pre-existing slopes; subsequent streams are in a measure independent of such slopes. (2) The courses of consequent

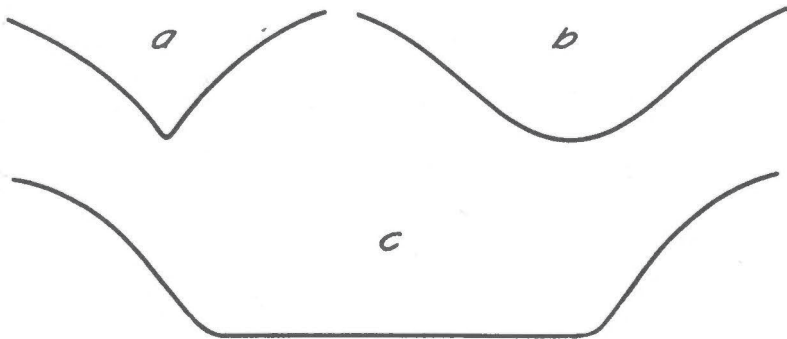

Fig. 31.—Cross sections of valley. *A*—Young valley showing by its form that down-cutting has been more active than widening. *B*—Older valley, in which down-cutting is retarded while widening proceeds. *C*—Much older valley with flat bottom (flood plain) and bluffs.

streams develop from source to mouth; those of subsequent streams from mouth to source. All of the ravines and nearly all the smaller streams in this area are subsequent.

**Down-Cutting.**—Down-cutting may go on rapidly for a time, but its effect is to diminish the slope from any one point to the point of discharge. This slope cannot be reduced beyond a certain degree, for the material constantly washing into the gully must also be washed out. If the washing out process fails to keep up with the washing in process, the gully will fill up, and the slope toward its mouth will again be increased. So long as down-cutting is active the side slopes are steep, and may increase in steepness toward the axis (Fig. 31).

**Widening.**—Since the effect of cutting down the axis is to increase the steepness of the sides, the washing and wasting of these is thus favored and the gully is thereby widened. The deeper and wider the gully becomes the longer are its slopes, and the more material is washed from them into the channel. In the early stages, while these side slopes are short, the deepening process has the advantage and the

gorge is accordingly steep. Later the wasting of the sides overtakes, as it were, the corradng of the axis, and there may come a time when the power of the stream in the axis is all used in transporting the sediment furnished to it by the wash of its sides and head. The resulting inability to cut down the channel is shown in the slopes of the sides which become constantly more gentle. If the new valley is alone in a considerable area it widens indefinitely, but if it has neighbors its

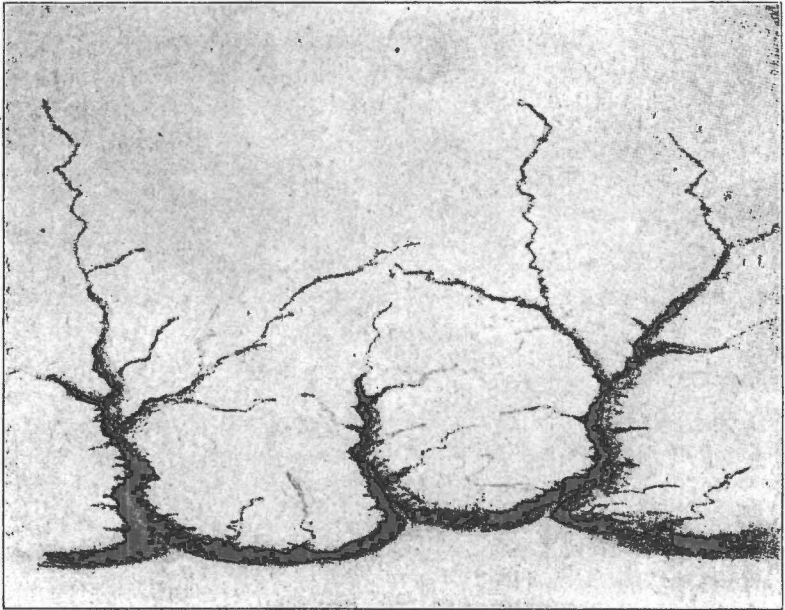

Fig. 32a.—The deepening, widening, and lengthening of valleys. This figure represents an early stage; compare figs. 32b, p. 87, and 32c, p. 88. (Salisbury and Atwood.)

own slopes and those of its neighbors ultimately meet and form sharp divides. The slopes of each can then continue to cut lower, but neither valley can widen except at the expense of the other.

**Headward Growth.**—For reasons similar to those which cause a valley to widen, it is also elongated headward. The headward growth of gullies is, or should be, familiar to all. If the valley cut down without widening, the slope of the sides would have to be vertical, which soon becomes impossible. So also, if the valley cut down without lengthening, the slope at the head would have to be vertical, which is equally impossible. The essential fact in both cases is that the cutting down of the foot of a slope steepens it and thus promotes erosion. Only, this erosion at the gully head is more rapid than that on its sides because more water comes in at the head.

The headward growth of a valley is subject to the same limitations as its widening. So long as it exists alone, such headward growth

may go on indefinitely, though at a constantly diminishing rate. Sooner or later, however, it meets other valleys leading in the opposite direction and a sharp divide results. The two valleys or streams are then in *headwater opposition*. Both slopes may then be cut lower, but neither valley can elongate headward except at the expense of the other.

It will be observed that what is here said about deepening and widening is almost equally applicable to consequent streams. Headward lengthening, however, is a distinctive characteristic of subsequent streams.

**Branching.**—For various reasons the headward growth of a valley

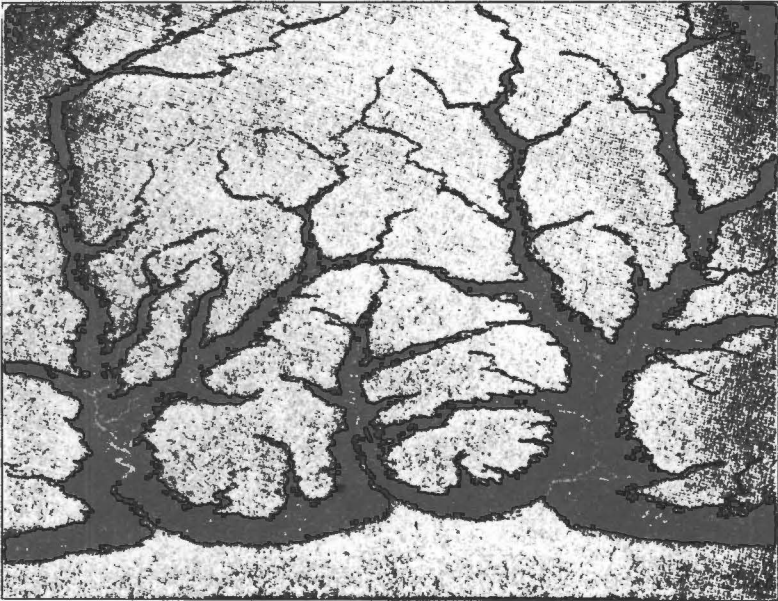

Fig. 32b.—A later stage in the deepening, widening and lengthening of valleys, (Salisbury and Atwood.)

is not generally confined to a single line. More than the average supply of water may enter from several directions. This may be caused by initial slopes which, although far too gentle to constitute stream valleys, are sufficient to determine the direction in which gully heads shall grow. Instead of a greater supply of water from one direction, the rock may be weaker along certain lines and thus favor the headward growth of gullies. This is true where the rock is cut by jointing cracks. Such joints are enlarged by weathering and, even though filled with disintegrated rock, erosion is tempted to follow such lines.

Where strata are inclined and outcrop in bands as in figure 23, page 53, it is almost certain that subsequent streams and valleys will develop on the outcrop of the weaker beds. Thus it happens that

subsequent streams may show a striking parallelism. Where there is no discernible condition governing the headward growth of valleys they branch in all possible directions, and are called *dendritic*, from their resemblance to twigs on a tree. Subsequent valleys are rarely found simple and solitary. If given sufficient time they increase in number, length, width, and complexity, until the original land surface has disappeared and the entire area has become valley slopes.

### *Cross Sections of Valleys*

Repeated allusion has been made above to the effects of certain processes on the steepness of slopes. These find their expression in

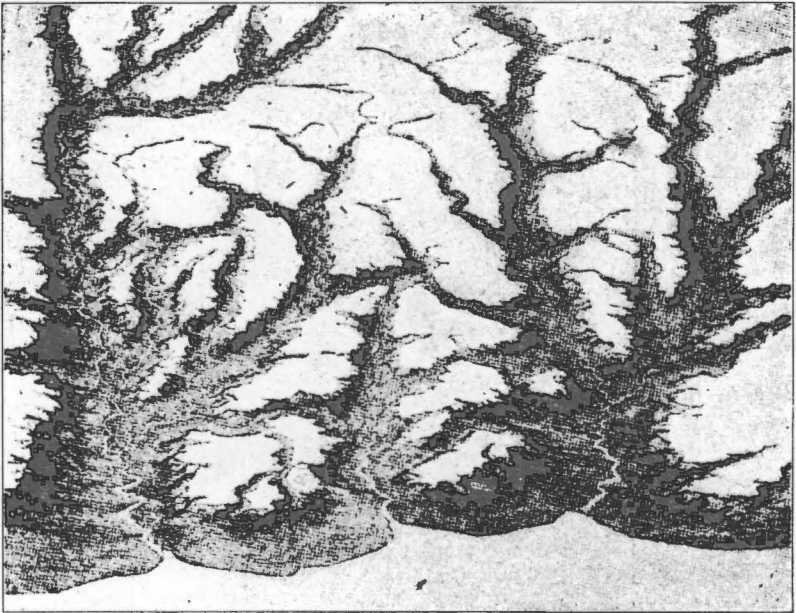

Fig. 32c.—A still later stage in the deepening, widening and lengthening of valleys (Salisbury and Atwood.)

the cross section and profile of the valley. In general, the shape of the cross section depends on the relative vigor of two processes, corrasion of the channel and wasting of the slopes by weathering and unconcentrated wash. The former tends to make the valley relatively narrow and deep. This is the case with young valleys, which are frequently V-shaped. The latter tends to make the valley wide and relatively shallow. This shape characterizes old valleys. If the vigor of down-cutting be great as compared with widening, the side slopes often increase in steepness as the central channel is approached, that is, they are convex upward (Fig. 31, p. 85). With less proportionate vigor

of down-cutting, this convexity disappears. With still less vigor of down-cutting, the side slopes become compound curves, steepest at intermediate heights and flattening as the axis is approached, that is, the valleys become U-shaped. It is not to be understood that streams in U-shaped valleys are as a rule aggrading their channels, nor even that they have ceased to degrade. In a later stage, valleys have flat bottoms and bluffs. The development of these features depends on meandering, which must first be explained.

### *Meandering and Flood Plains*

**Cause.**—At any fortuitous curve or turn, the stream's power is to some extent concentrated on the outer or convex side of the channel,

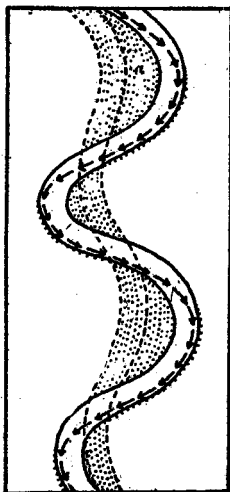

Fig. 33.—Diagram illustrating an early stage in the development of meanders. The dotted portion represents the area over which the stream has worked.

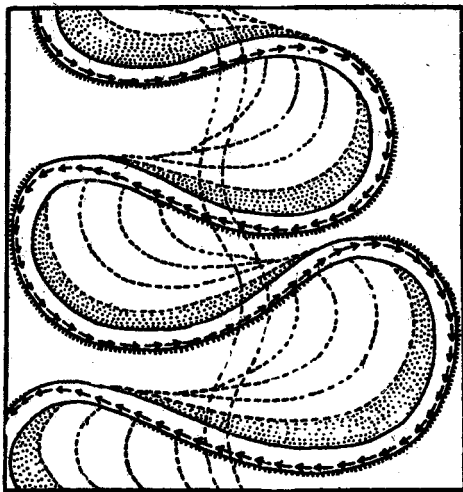

Fig. 34.—A later stage in the development of meanders. The several curves have not only widened their swing, but have moved down stream. Both from Salisbury's *Physiography*, p. 187; courtesy of Henry Holt & Co.

leaving the water on the concave side with less than its average velocity. At such a time, if the average down-cutting power of the stream be sufficiently small in proportion to its load, its power on the inner side or the curve becomes actually deficient, and deposition takes place in the channel against the inner bank (see p. 83). The effect of this is to narrow the stream, whose power is then still further concentrated against the outer bank. The shifting of the channel which is initiated in this way tends to make curves of somewhat uniform sharpness, their radii depending on the volume and power of the stream and the nature of

its load. When well developed, such curves are called meanders or ox-bows (Fig. 34). It is to be observed that the conditions of meandering are not limited to aggrading streams, or even excluded from degrading streams. The one essential is that in going around a curve the distribution of power shall be such that the power on the inner side of the curve falls below what is necessary to carry the load; that is, the load must be sufficiently near the stream's capacity so that it shall be locally in excess in the relatively quiet water at the inside of a curve. The Little Miami has good meanders in its lower course, yet it is not an aggrading stream. It has probably ceased to deepen its valley with reference to the adjacent hilltops, which are themselves beginning to cut down, but the valley bottom is likewise slowly cutting down, or at least not building up.

**Change in Form of Curves.**—The manner in which meanders originate implies a constant change of form. The more the stream cuts to one side the more sharply curved does it become, and the sharper its curvature the more does the stream cut on the outside of the curve and deposit on the inside. The ultimate effect of this tendency is to produce closed curves, formed by the stream's intersecting itself (Figs. 33 and 34). The completed circle or closed curve is then abandoned, and the stream is temporarily straighter than before. In this way, cut-off or ox-bow lakes are formed. For a time such abandoned arcs are in free communication with the new channel, but as the muddy water of the stream enters the ends of the abandoned curve its motion is lost and some of its load drops. Thus a dam is soon built at each end, and the remnant of the old channel becomes a closed basin.

**Change in Position of Curves.**—If any one meander curve be mapped in successive years, it will be seen to change its position as well as its form. Each meander is found to be moving down stream (Fig. 34). This is because a stream, in flowing transversely across its flood plain, cuts more rapidly on that bank which is on the down-valley side. This down-stream migration of meanders is important. The river at each meander swings only toward its outside curve; therefore, so long as a meander does not move down stream there can be no return of the stream toward the other bluff except by a cut-off. But as a curve which is cutting toward the right moves forward, that is, down stream, a curve which is cutting toward the left occupies its place and the stream begins to swing toward the other bluff without a cut-off. Thus the stream at any one place is observed to swing from side to side, a thing which it would not do if the meanders did not migrate down stream.

**Planation.**—The work done by a stream in the process of meandering is both destructional and constructional. Its destructional work is done against the outer bank of each curve. This bank may consist of the river's own alluvium, or of the original material in which the valley is cut. In either case the river planes the country to its own level

and produces a flat which is co-extensive with the area over which the stream has meandered. This process is *planation*, and is the essential process concerned in making a flat bottom in a valley which is not being aggraded. Even in such a case there is a coating of alluvium, but its thickness is roughly uniform and it is, therefore, not the primary cause of the flat.

The flat bottom is limited by slopes which are commonly steeper than any slopes of the original surface, because made by the cutting of the river at their base. These slopes are the bluffs. Their distinguishing characteristic is their steepness, and their chief significance in the history of the surface lies in the fact that they mark the lateral limits of the stream's meandering and planation. They are, therefore, composed essentially of the material in which the valley is cut. Usually this is not alluvium, but where a stream has cut down beneath its flood plain and formed terraces, bluffs are cut in the older and higher alluvium. In this case those cut in the original country rock may be distinguished as the *outer bluffs*.

Where a stream, meandering on its flat, flows at the foot of its bluffs, it is widening its trough and flood plain. This is seen most strikingly where the hill rises directly from the river's edge with a slope so steep as to be bare of vegetation. All such cases occur on the outside of the river's curve and indicate that the stream is planing off the hills which limit its trench. The bluff is, in fact, only the limit of such

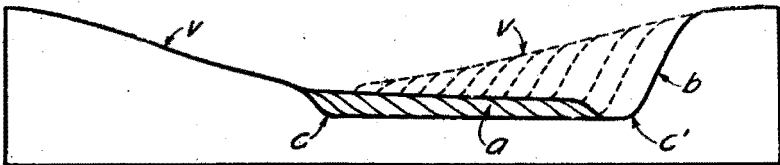

Fig. 35.—Making a flood plain by planation and lateral accretion of alluvium. *a*—Original valley slopes. *b*—Bluff being cut away at the base by the stream. The parallel dotted lines show successive positions of the bluff as the channel shifted from left to right. *c*—Original channel. *c'*—Present channel. *a*—Alluvium, deposited on the left side of the channel as the latter shifted toward the right. By subsequent shifting to the left the stream will cut a similar bluff on the other side of its valley.

planation. A good illustration of this process is seen at the "Blue Banks" opposite New Baltimore, and another at the "Cedar Cliff" on the Little Miami just below Miamiville. Where a railroad runs between the river and the foot of its bluff, as the Norfolk & Western does at places opposite Milford and Terrace Park, or as the Pennsylvania does at various places in the Little Miami Valley, expensive work and frequent repairs are often necessary to prevent the roadbed from being washed away by the river in its efforts to widen its valley.

**Alluviation.**—The constructional work involved in meandering consists largely in the deposit of sediments on the inside of meander curves, the reason for which has already been explained. (See p. 83.) The effect of this is to follow up the shifting stream with a deposit (generally sand and gravel) laid in oblique layers (Fig. 35) as high as the surface of the river. The bottom of this deposit is the planation surface made in the stream's meandering. The alluvium therefore constitutes a mere veneer whose surface is approximately parallel to the bed on which it rests.

Alluviation also includes the deposition of material from suspension in flood waters. Since the deposition from suspension is due to loss of agitation, it occurs most abundantly where there is a check in the velocity of the water. This is chiefly at, or just outside of the natural banks of the stream, for the contrast between the violent swirl of the flood within the channel, and the conditions over the nearby plain, is greater than the contrast within a similar distance at any other place subject to overflow. If the stream is entirely unable to cut down its channel, this extra accumulation on its banks will result in "natural levees," or a slope of the flood plain away from the stream (Fig. 36, p. 93). This is very conspicuous on the Lower Mississippi, but is not the case in this area. Along streams which, in the long run, are able to cut down their channels, this extra deposit of silt near the bank is washed into the stream between floods and is therefore not cumulative.

**Flood Plain Making.**—The making of flood plains by meandering alone involves two very characteristic processes, planation and deposition within curves. The latter may be distinguished as *lateral accretion*, and contrasted with *vertical accretion*, which consists in raising the height of flood plains by layers of mud dropped from suspension in times of overflow. In the building of most flood plains, lateral accretion is far the more important process. Some flood plains are built entirely without overflow.<sup>1</sup>

In a section through an alluvial plain the amount of accretion due to each of the above methods may be roughly determined by the nature of the material. Most of the sand and gravel has been deposited by lateral accretion and is not due to overflow, though some has been laid down in channels traversing the flood plain and used in time of flood only. On the other hand most of the silt which is incorporated in the flood plain has been laid down from suspension in times of overflow.

**Slopes of Flood Plains.**—In speaking of planation no account has been taken of the fact that the stream may, while shifting laterally, also be cutting its channel lower or may even be aggrading. In the former case, the surface of planation will not be horizontal but will decline toward the stream. This will become clear by assuming that in

<sup>1</sup>The Writer.—Flood plains produced without floods. Bulletin Amer. Geogr. Soc. Vol. XXXVIII, p. 89, 1906.



figure 35 the channel becomes progressively lower while shifting from *c* to *c'*. The steepness of the slope toward the present channel will be determined by the relative rates of the lateral shifting and the downward corrasion. Since the thickness of the alluvium laid down is approximately uniform, a flood plain surface thus formed has about the same slope as that of the palnation surface. Even though vertical accretion be large in amount, and though it be much greater near the stream than at a distance, it is generally insufficient to reverse the slope of the flood plain of a cutting stream, because the thicker layer of mud near the stream is in a relatively exposed position, and liable to wash

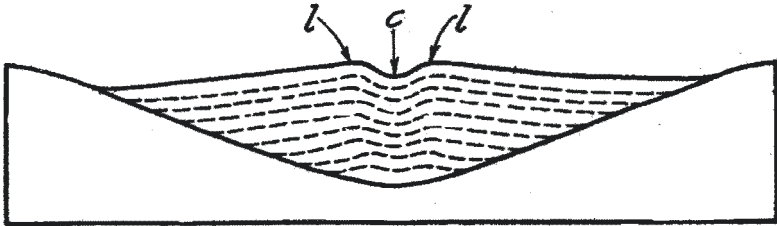

Fig. 36.—Building up of flood plain by material deposited by floods. (Vertical accretion.) *c*—Channel. *l*.—Natural levees. Shifting of channel, planation, and lateral accretion which commonly accompany this process are not represented in the figure.

back into the stream. It may, therefore, be stated as a general rule that flood plains of degrading streams slope toward their streams (Fig 37, p. 94). This is true of all flood plains in the area here described.

Aggrading streams, on the other hand, habitually build up their channels and are necessarily subject to floods, thus building up their flood plains as shown in figure 36, above. It may therefore be stated as a general rule that the flood plains of aggrading streams slope from the streams toward the bluffs. This is nowhere better illustrated than on the flood plain of the lower Mississippi, where the slope from the river's bank is frequently seven feet in the first mile, and sometimes as much as twenty feet in all.<sup>1</sup>

**Alluvial Terraces.**—Many valleys having bluffs and flood plains have also alluvial terraces, that is, nearly level tracts of land at higher levels than the flood plain. Generally these lie between the flood plain and the bluff though they may be entirely surrounded by flood plain. Frequently there are terraces of different levels, rising like a gentle stairway toward the bluff. Alluvial terraces are remnants of old flood plains. They may be developed in the normal process of a stream's down-cutting, or they may represent some decided change in the stream's life. The latter is the case with the fine terraces along the Miami, Little Miami, and Ohio.

<sup>1</sup>Note the Donaldsonville, La., topographic sheet of the U. S. Geol. Survey and other sheets in the Mississippi delta.

In these cases the terraces were made by first filling the great valleys to a level even with the terrace tops. This had to be done by aggrading streams. Later, by an increase of power or a decrease of load (see History, p. 160), the streams began to degrade and carry away the material with which they had once filled their valleys. Thus they cut to lower levels, leaving the present terraces as the only remnants of the original filling. When made in this manner, terraces on opposite sides of the valley are, of course, equal in height. The business part of Cincinnati and Covington stands on such terraces. (For further examples see pp. 26, 30 and 31).

The making of alluvial terraces in the normal course of a stream's down-cutting is illustrated by figure 37. It has been shown that a stream which is cutting downward, while shifting laterally, makes a plain which slopes toward the stream. It is frequently the case with very wide

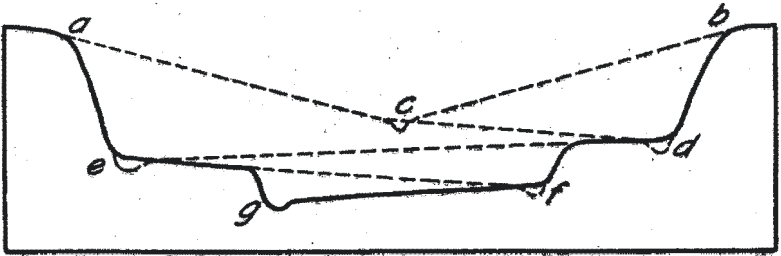

Fig. 37.—Making of alluvial terraces during uninterrupted down-cutting and meandering. *c, d, e, f, g*—successive positions of the stream channel. (Compare Fig. 35). The present surface is indicated by the full line. Former surfaces destroyed by erosion are shown by dotted lines. *a, c, b*—original valley; *cd*,—first flood plain; *de*,—second flood plain partly preserved as terrace; *ef*,—third flood plain preserved as terrace; *fg*,—present flood plain.

flood plains that their outer margins are too high to be flooded. A stream which has shifted eastward and then again westward while corradating its channel downward, may easily find, before reaching its original position, that the remnant of its old flood plain on the west is too high to be flooded (Fig. 37). In repeated shiftings it may leave any number of flood plain remnants at different heights. This condition calls for no sudden changes in the habits of the stream. In this case, terraces on opposite sides of the valley do not have the same height. All of the younger terraces of this region were made in this way, that is, all the terraces which are intermediate in height between the present flood plains and the old valley filling described on pages 150-153.

### Grading

By the *profile* of a stream is meant the form of its bed considered with reference to its slope only. It therefore ignores the stream's

lateral turns or horizontal plan. It may therefore be represented as a curve in a vertical plane (Fig. 38). Corrasion and deposition tend to give continuity to this curve, that is, to do away with repeated changes from gentle slope to steep, and the reverse. The process by which this is done is called grading. On slopes which are too steep the stream has power to spare and will use this power in cutting down. It cuts more near the upper end than the lower end of such a slope. Thus the steep slopes lose part of their steepness. When the stream reaches the flatter slope it may find itself overloaded and obliged to deposit some of its load. This it does at the upper end of the gentle slope, thus increasing its steepness. These processes continue until the profile is harmonious throughout. The final result is not a *uniform slope* but it is a *continuous slope*, which is concave upward, being steeper near the headwaters. This is because the stream needs a greater

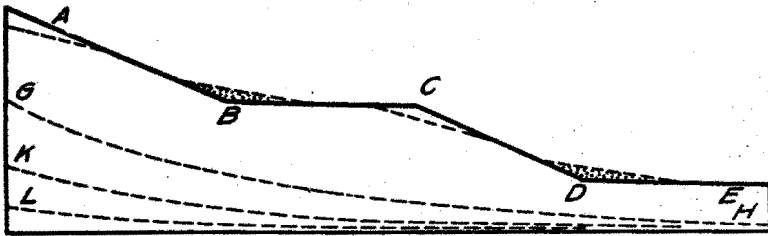

Fig. 38.—Grading of a stream channel. The steeper portions, AB and CD are cut down first at their upper ends, thus decreasing their grade. The flatter portions, BC and DE, are built up at their upper ends, thus increasing their grade. The entire course tends toward a continuous, but not uniform curve similar to GH. Later stages in the stream's life are represented by the profiles K and L.

slope where it is small and its power is, to a large extent, used up in friction on the bed. When a stream, even though flowing over strong and weak rocks, has produced such a profile, it is said to be graded.

The ratio of power to load is an important consideration in grading. On the steep slopes the former is in excess; on gentle slopes the latter. The equalizing of slopes, as described above, tends toward a condition in which the power will everywhere be just sufficient to transport the load, but not to corrade the channel, except as the neighboring slopes and hills are simultaneously worn down. It may be shown that the continuous and harmonious slope is reached only when the stream's power has just become equal to its needs for transportation. For, so long as a stream has surplus power it will make a distinction between strong and weak rocks, having its profile steeper on the strong than on the weak; but when power and load have been equalized no such distinction appears.

The small streams emerging from the bluffs in this area are in general above grade. Their surplus power is revealed by (1) the steepness

of the side slopes of their V-shaped valleys, (2) the steepness of their profiles, especially near the valley heads, and (3) the inequalities of their profiles, many of which show rapids and small falls of the Niagara type (Pl. II-A). Many of these streams are well graded in their lower portions but not near their heads.

### PROGRESSIVE CHANGES IN TOPOGRAPHY

The combined effect of all the erosional processes described above is a progressive change in topography. The nature of these changes is so well known that if the form and materials of the original land be given, the succession of topographic features can be predicted until the entire area shall have been cut down so near to sea level that running water can have no further effect. Regardless of initial form, this is the fate of all land masses unless the process is interrupted. Or, if the topographic features at any stage be given, former features may be known and even, to a considerable degree, the form of the original uneroded surface.

The succession of features of interest in this area is that which begins with a somewhat elevated plain or low plateau more or less abruptly limited by steep edges, such as are represented by the present bluffs.

#### *Beginnings of Dissection*

The first effect of running water on such a surface is the making of gullies at its edge. (See Fig. 32-a, p. 86). These grow headward and send out branches until, by the work of many such systems, the edge of the area has lost its flatness and consists of hills and ridges. This is the condition in which this area is found for some miles back from the main streams. It does not afford a perfectly exact and simple illustration of the beginning of dissection at the edge of a plateau, for, as noted elsewhere (p. 100), the present valleys are not being elongated headward in a plateau which is entirely devoid of valleys. The present streams are rather to be considered as deepening the lower courses of shallow valleys already in existence, as will be seen later in the discussion of the history of the present surface (p. 159). Nevertheless the topography shown at the present time differs little from that of a low plateau edge being dissected for the first time. The largest approximately level tract is found along the line of the Cincinnati, Lebanon & Northern Railway. Its width is gradually being reduced by headward growth of small streams on both sides; on the west by tributaries of Mill Creek; on the east by those of the Little Miami.

#### *Mature Dissection*

So long as the dissection of a plain surface is not complete, many hills and divides continue to rise to about the same height, which is

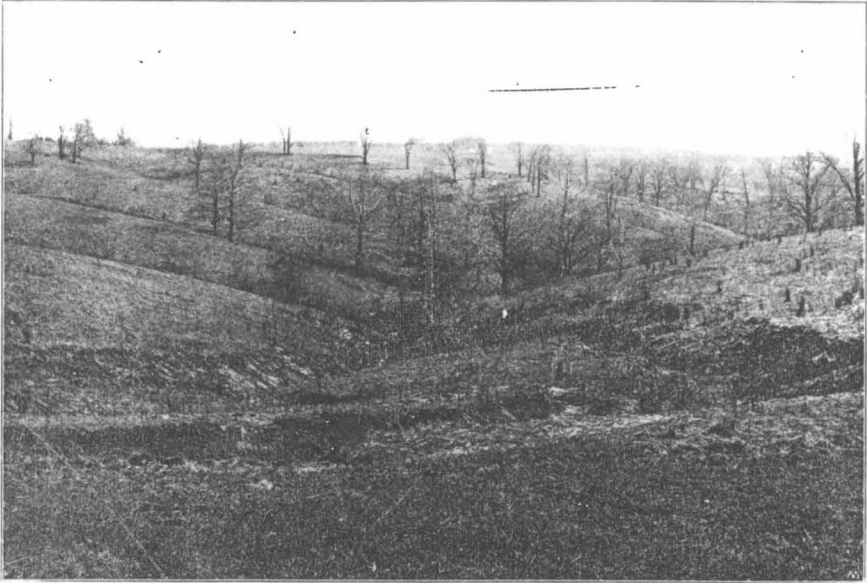

A.—Reviled valleys in upland, West Covington, Ky., city park tract.



B.—Distorted sand and gravel beds in kame, Camp Hageman. (See p. 155.)

approximately that of the original surface (Fig. 39). They have varying widths, and all are being narrowed by the wasting of their sides, but they cannot be much lowered so long as any part of their flat tops remains. The narrowest will first be reduced to points or crests, after which the continued wasting of their sides will lower their crests. Ultimately every ridge must thus begin to cut down. When practically all of the original flat upland has thus disappeared the country is said to be completely or *maturely* dissected.

Most of the uplands of this area are in this condition of mature dissection. The hills and divides have been narrowed to points or



Fig. 39.—Diagram illustrating progressive dissection of a plain surface. The stage represented by line (1), shows flat hilltops of unequal breadth and several which are already reduced to points or crests. In the second stage the points are cut down and the flat tops narrowed, one of them to a point. In the third stage no flat tops remain and dissection is *mature*. In an extended area a number of other hills would be found rising approximately to the level of the original plain surface. In the fourth stage all are approaching base level, but there is no longer any uniformity of height. It is to be understood that in nature the slopes would be curved as in figure 31, page 85. This diagram also illustrates the principle that the maximum relief of a dissecting plateau occurs at the stage of maturity.

ridges, but so many of them still rise to about the same height as to leave no doubt that the level thus marked is, essentially that of the former plain.

Since the hilltops have held their own up to the time of mature dissection, while the valleys have been deepening, the relief is greater now than ever before. It is also greater than it will be in the future, for it may be shown that henceforth the hilltops will cut down more rapidly than the valley bottoms. (Compare the diagram, Fig. 39.) The stage of mature dissection is therefore also the stage of maximum relief. The slopes are longer than they have ever been before and steeper than they will be at any later stage. The run-off is therefore at a maximum and likewise the power of the streams. Therefore, also, the load of sediment is greater than at any earlier or later stage. Maturity is therefore characterized by *maximum dissection, maximum relief and maximum slopes, run-off, stream power, and load*. It does not follow that the stage characterized by these maxima should coincide with that at which streams reach *grade*. Graded stream valleys are sometimes called "mature." If that word is used in both these senses

it often becomes necessary to speak of a region as mature while the valleys which dissect it are still young. Such is the case with the mature portions of the area here treated. The confusion thus threatened can perhaps best be avoided by dropping the use of the word "mature" with reference to streams and valleys. For this purpose the word "graded" expresses all that is intended.

### *Wearing Down of Hills*

After maturity is passed the hills lose their uniformity of height, for the crests of the narrower ones not only begin to be lowered sooner, but are cut down faster than the broader ones. With continued erosion

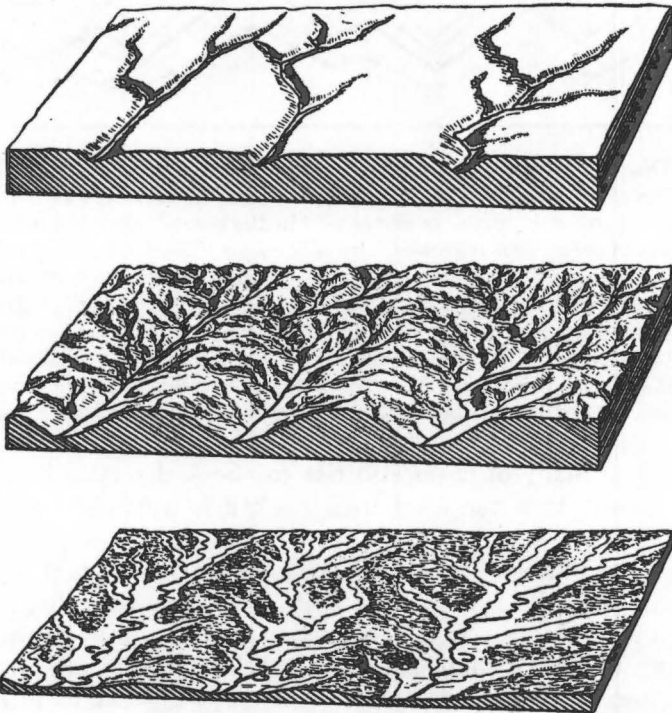

Fig. 40.—Plateau in youth, maturity and old age. (Blackwelder and Barrows, *Elements of Geology*). Compare Figs. 32a, p. 86, 32b, p. 87, and 32c, p. 88.

toward base level the relief decreases, and with it the inequalities among hills, until the entire area is but little above sea level. Being "almost a plain" it is then called a *peneplain*.

**The Peneplain in This Area.**—There is no simple illustration of this stage of erosion in the area here considered, that is, no peneplain is now found at the level at which it was made. The geological evidence is however complete that the once nearly flat surface of the upland

was produced in this way. The present hilltops and ridgetops which are of nearly uniform height are all that remains in this locality of a well developed but subsequently eroded peneplain. When made, it was but little above sea level. The present deep valleys were, of course, impossible at that time. Whatever streams then existed must have been without cutting power, and meandered widely over the nearly flat land. The making of this peneplain is among the most important events in the history of the present surface. (See. p. 112.)

### *Renewed Uplift*

**Cycles.**—When an old peneplain is elevated erosion has renewed power, and dissection of the surface is again begun. In many respects this second dissection resembles the first. Both begin with a plane or nearly plane surface and end with the same, passing through a stage of mature dissection and maximum relief. The essential repetition of the same processes and features in similar order has caused the term *cycle* to be applied to the entire round of events from the beginning of erosional work to its close, or sometimes to the time required for all. A region may thus pass through any number of cycles, according to the number of times it is uplifted. This region illustrates the dissection of a low plateau in its second (or later) cycle. Many other cycles may have been completed before the first one of which record is left. The present cycle is loosely called the second, only because the one which ended with the peneplain (represented by the present hilltops) is the oldest of which a record is left.

**Rejuvenated Streams.**—It has already been shown that when a peneplain is uplifted the power of its streams is again increased. They are then said to be revived or rejuvenated. The effect of this is to cut down rapidly, thus making a deep and narrow *young* valley within the shallow and wide open *old* valley (Fig. 41). The same effect is produced when the mouth of a stream is lowered, or when, for any other reason, the cutting power of the stream is increased. The features due to rejuvenation are well shown in the valley of West Fork Creek. (See p. 159, also Plates V-A and IX.)

An interesting phase of revived streams is seen in the Licking and other Kentucky streams tributary to the Ohio. In this case the streams at the end of the first cycle were wandering over the peneplain in an intricate system of meanders. When the peneplain was uplifted and the streams were revived, these streams cut young gorges 200 to 300 feet deep in the uplifted plain, retaining at the same time their meandering course. These curves are now *entrenched meanders*. The old flood plain on which the meanders developed is represented by the tops of the present bluffs. A new flood plain is being made by continued meandering and lateral corrasion at the present level of the stream. It is plain



that such features cannot be produced in a single cycle of erosion, but can result only from rejuvenation. This principle is beautifully exemplified by Kentucky River and by Licking River south of this area. The broad curve of Licking River within this area near its southern margin is of the same character.

**Stream Courses of the Second Cycle.**—Unless the land is submerged at the close of the first cycle, or the old valleys are effaced in some other way, the second cycle is not in all respects like the first. If valleys, however shallow, remain after uplift, their courses need not

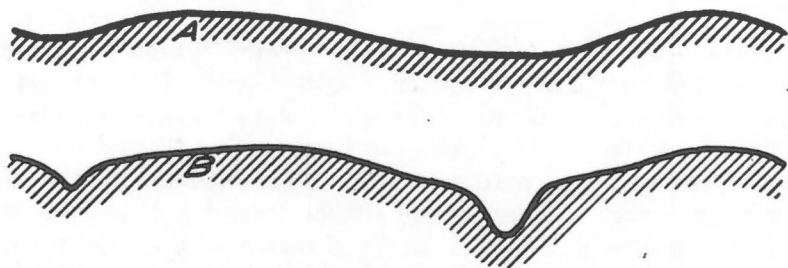

Fig. 41.—A—cross section of old valleys. B—the same valleys rejuvenated.

be again determined by the process of headward elongation. To a certain extent the country will have a "ready made drainage system." Nevertheless, if the old surface be uplifted without filling, the streams near the center of the area are not at once rejuvenated. The effects of uplift are first felt near the edge where the streams descend to lower levels and their gradients are steepened. Rejuvenation and down-cutting begin, therefore, in the lower courses of the streams, and as these are cut down the renewed activity advances up stream until it reaches the headwaters. This is the way in which rejuvenation occurred in this area when the old penplain was uplifted. The effects of rejuvenation have now advanced nearly or quite to the heads of the old valleys.

It thus appears that many of the valleys in this area are in their second cycle, but some came into existence in the glacial epoch, and are, therefore, now cutting down for the first time. (See p. 120.)

## CHAPTER V

# THE WORK OF GLACIERS

### FORMATION OF GLACIERS

**Valley Glaciers and Ice Caps.**—The most common conception of glaciers is derived from mountain regions like the Alps or Canadian Rockies. Such glaciers occupy mountain valleys, and there should be no confusion when they are sometimes called mountain or *Alpine* glaciers, and at other times *valley* glaciers.

In colder latitudes ice of the same nature may form a broad sheet covering a perfectly plain surface, or it may cover a rough surface so deep that the highest hills, or even low mountains, are obscured. Such a sheet is also commonly spoken of as a glacier, but it should be distinguished as a *continental glacier* or *ice cap*. Such an ice cap now covers Greenland, having an area of at least 300,000 square miles. A similar cap covers perhaps several million square miles of the Antarctic continent. The ice of such continental glaciers may be at places several thousand feet deep.

**Névé.**—All glacier ice is derived from snow where the annual snowfall exceeds melting, and is not, like ordinary ice, formed directly by the freezing of water. The gradual change from snow to ice may be observed even in the latitude of Ohio. When a deep pile of snow is protected from melting until late spring, it may be observed that the once flaky snow has become granular like a mass of small pellets. Those who have tried to make snowballs in the late summer from the snow on high mountains which may have lasted over many seasons, will recall the same granular condition still more pronounced. Each grain is a pellet of pure solid ice. By a process not here explained, these pellets get larger as time goes on, some no doubt disappearing and giving their substance to others. In this condition the material is called *névé*, a term taken from those parts of the Alps where French is spoken. The term *névé*, while used in this sense to designate the material, is used also in a slightly different sense to designate the great snow fields which cover the mountain slopes above the level of the glacier.

**Glacier Ice.**—Where the *névé* is very deep, as in a mountain valley, its own weight presses the lower granules very close together, compacting them into a solid mass. This is helped by melting at the surface, the resulting water trickling down and freezing in the pores. By these two processes *névé* becomes glacier ice. Those who visit glaciers should

not fail to pour a little ink on a piece of the ice. The ink follows the lines or seams where the granules meet and thus outlines their form. In most glaciers their sizes range from that of peas to that of cherries, but they may be as large as oranges.

Thus at the upper end of the mountain valley the ice is confined to the bottom where the pressure is great. All above is névé, and at the surface ordinary snow. As the same material creeps very slowly down the valley, consuming much time in its progress, it changes more and more to ice. The greater warmth of the lower valley may destroy the snow cover, so that in late summer many glaciers carry no snow at their lower ends (Fig. 42).

**Movement and Crevasses.**—The forward movement of an Alpine glacier is in part (though not wholly) a mere matter of sliding down grade. The grade may change from place to place. The valley also

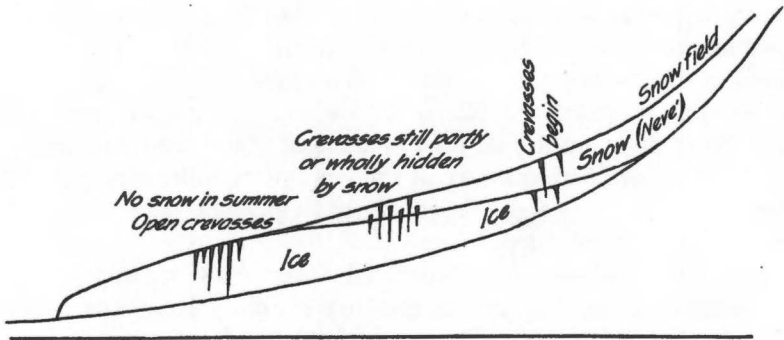

Fig. 42.—Longitudinal section of Alpine glacier showing relation of snow to ice.

widens and narrows alternately and its course is far from straight. On these accounts the glacier cracks or forms *crevasses*. In fact, it is customary to define the limit of the névé (snowfield) and the beginning of the glacier by the place where crevassing begins. These crevasses may open a fraction of an inch or ten to twenty feet, and may be so abundant as to make the surface impossible to cross, especially after melting has widened their tops and narrowed the intervening ice blocks.

#### THE BEHAVIOR OF ICE SHEETS

**Former Ice Sheets of North America.**—In a late geological period, called Pleistocene or Glacial, snowfall greatly exceeded melting over the northern part of North America, and glacier ice accumulated to so great a depth that it spread southward over Ohio and the states west of it (Fig. 43). To some extent, no doubt, the general slope of the continent was southward, but to some extent also, the southward movement was a mere spreading out, due to piling up at the north.



Fig. 43.—Map showing the glaciated area of North America. The dotted lines and arrows show the direction of ice movement. That portion of the ocean which is left unshaded is less than 600 feet deep. It is continental shelf or "epicontinental sea." (See p. 57). That which is shaded darkest is for the most part more than 1,500 fathoms (9,000 feet) deep. (After Chamberlin and Salisbury).

**Thickness.**—The total thickness of the ice in Canada may have been a few thousand feet. It was doubtless a few hundred feet thick in the Miami Valley. Generally speaking, it began to grow thinner by excessive melting after crossing the Great Lakes. Over northern Canada, at least, the snowfall exceeded melting.

**Movement Over an Uneven Surface.**—The surface of the ice necessarily sloped in the direction indicated by its movement, but this did not prevent the glacier from crossing great valleys like those of the Great Lakes, a hundred or more miles in width and a thousand or more feet in depth. The ice filled these valleys, and must therefore have been 1,000 or more feet thicker in the basin of Lake Superior than on its margins. It was able to climb the slope to the southern margin because the slope of its upper surface was always in that direction. The ice therefore moved up hill in much the same way that water does when flowing over a dam.

The rate of ice movement may have been a few inches or a few feet per day. In moving over the land, the ice was obliged to accommodate itself to the uneven surface. In any one position the ice was fitted to hills and valleys as a die fits a mold, but the same surfaces would not fit when the ice had moved forward to a new position. Thus the ice was continually obliged to fit itself to new topographic forms. This it did partly by breaking and refreezing. Ice also melts more readily when subjected to pressure, hence where it pressed unusually hard against an obstacle there was a tendency to melt a hollow in the ice to fit the obstacle, and where a gap was left between ice and earth water might accumulate and often freeze.

But the accommodation was not all on the side of the ice. The hills and valleys were obliged to compromise. The former were worn down where ice was thick and heavy, but not in southern Ohio where the ice was relatively thin and rapidly wasting. Valleys were in many cases filled or partly filled, either temporarily by stagnant ice or more permanently by rock debris. There were also other and less simple ways by which the ice was continually molded and remolded to the surface over which it moved.

**Advance and Retreat of Front.**—As already stated the ice is constantly moving forward, melting meantime both on the top and at the edges. By reason of this continual advance of ice from a colder region, the glacier is able to survive indefinitely in a region where melting greatly exceeds the snowfall. At length, however, its front reaches a position where the rate of melting at the edge equals the rate of advance. Beyond this it cannot advance. So long as this balance continues the edge remains stationary. But the balance is liable to disturbance. The climate may become temporarily warmer or colder or the volume of on-coming ice may be greater or less. In either case the edge of the ice shifts. This is important in the area near the Ohio as will be seen later.

**Lobes.**—Important effects are produced at the edge of the ice by large valleys where these trend in the direction of the ice movement, as was the case with the Miami, Little Miami, and Mill Creek valleys. Regarding the surface of the ice as essentially a plane, it is clear that in such cases the ice is much thicker in the large valleys than over the intervening divides. Moreover, its movement, where thin, is more interfered with by friction, and it is more easily broken up. It is easily understood that thin ice melts quicker than thick ice. It comes about, therefore, that large valleys thus situated are often occupied by glacial ice when the intervening higher ground is bare. This is probably much more apt to be the case during the retreat of the ice front than during



Fig. 44.—Glacial erosion on surface of limestone, Kelleys Island, Lake Erie. Photograph by Clara G. Mark.

its advance. The more important effects of glaciation may, therefore, be expected in the great valleys. This is abundantly illustrated near Ohio River as described later.

If valleys trend transversely to the ice movement they are more apt to be filled with rock debris if not too large.

#### LOAD CARRIED BY THE ICE

**Glacial Erosion.**—Several allusions have been made above to rock debris carried by the ice. The larger part of the geologic importance of glaciers in the United States consists in their relation to such material. Glaciers bear very heavily on the earth below and in their onward movement abrade a large amount of material, first the mantle rock and later the solid rock. This applies to those regions where the glacier is accumulating, or at least maintaining its full thickness and weight; not to such regions as southwestern Ohio where the ice was rapidly wast-

ing and unable to carry forward the debris it had already loosened, much less to erode the fresh bed rock. Kelleys Island in Lake Erie is well known for its beautiful illustrations of what the ice can do in grinding away, polishing, striating and fluting the solid limestone (Fig. 44). At that place all mantle rock must first have been swept away, but near the Ohio, not only was the bed rock not eroded, but much of the old pre-glacial mantle remains.

**Debris on the Ice.**—Alpine glaciers derive much debris from the steep side slopes of their valleys from which rocks roll down on the ice. The very nature of a continental glacier shuts this out. Only an exceptional mountain, called in Greenland a "nunatak," may rise above the ice. Its steep slopes, made steeper by the erosion of the ice at its foot, may drop debris on the ice which stretches out as a long dark train in the lee of the mountain, but aside from this exceptional case there is little or no opportunity for any rock material to get on the surface of the glacier. Continental glaciers, therefore, carry little or nothing on top. An exception may be found near their edges where dust has been blown on, or where melting has carried away all the clean ice of the upper portion and is at work on the debris-filled lower portion. The rock material thus set free accumulates on the surface and tends to prevent deeper melting.

**Debris in the Ice.**—Much of the material which glaciers erode from the surface is merely rubbed along between the ice and the earth, but much of it also is carried up into the ice, especially that which is eroded from hilltops. A great deal also is incorporated into the glacier by the ice freezing around it, and some of that which falls on top goes down into crevasses. In almost any mass of drift a number of stones will be found which have thus been carried in the ice at its base and scratched or "striated" by rubbing over others or over the solid rock of the bed. Similar scratches on bed rock are very useful in showing the direction of movement.

#### DEPOSITS MADE BY THE ICE

##### *Ground Moraine*

**How Deposited.**—The ways described above, in which glaciers obtain and carry their loads of rock material, suggest the ways in which it may be deposited. Perhaps the most important of all deposits, at least in the United States, are those made beneath the ice and known as ground moraine. So long as a glacier continues in a climate favorable to accumulation, its thickness and weight and the power with which it rubs on its bed are kept up, and little material can come to rest beneath it. This was the case in northern Canada. Before going very far north of the Great Lakes the traveler sees bare rock becoming more and

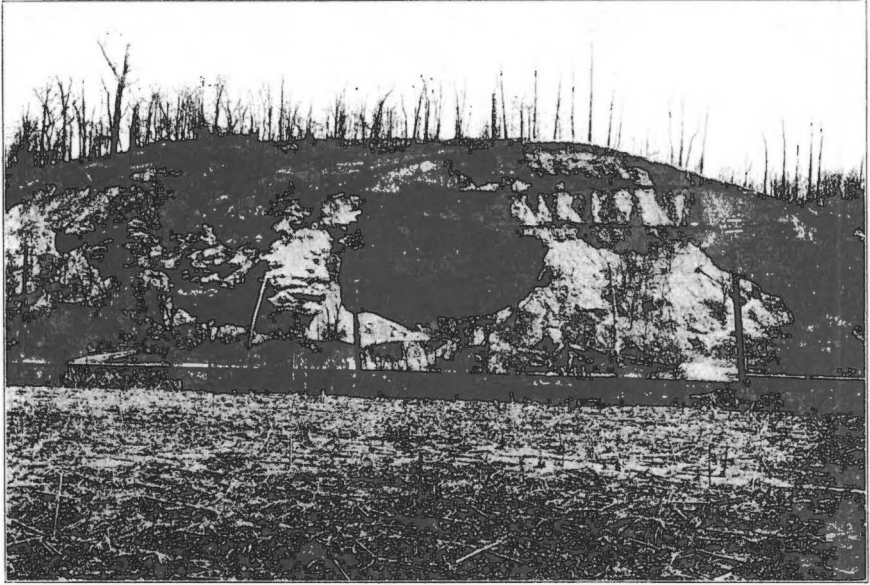

A.—Interbedded gravel and till in the Illinoian terrace near Coney Island. The eight-foot bed just above the telegraph pole is till. (See p. 134.)

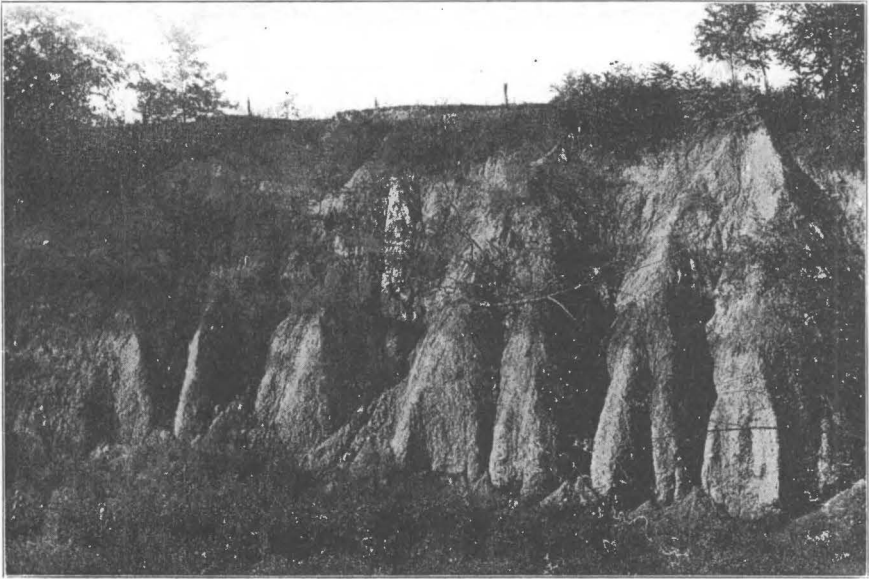

B.—Section on Twomile Creek, Hamilton, O., showing till of the Illinoian and Wisconsin glacial stages separated by four feet of loess or surface silt. The last appears as a dark band at mid-height in the picture. (See p. 147.)



more frequent. Even in northeastern Minnesota is a considerable area which was severely glaciated, but on which almost no deposit was left. When a glacier gets thinner and lighter it becomes unable to drag along beneath it all the load it has hitherto carried. The load therefore begins to lodge and form a sheet of ground moraine (Fig. 45). This is generally the case south of the latitude of Lake Superior. The change is a gradual one, but in the main the continental glaciers were not accumulating but wasting within the limits of the United States.

But the glacier is not to be thought of as invading the United States with a burden of detritus and depositing just enough at every stage to make up for the loss in carrying power. The glacier was not only depositing everywhere in Ohio, but everywhere taking up new burden. Therefore the detritus deposited at any given place consisted largely of material derived from no great distance. The proportions

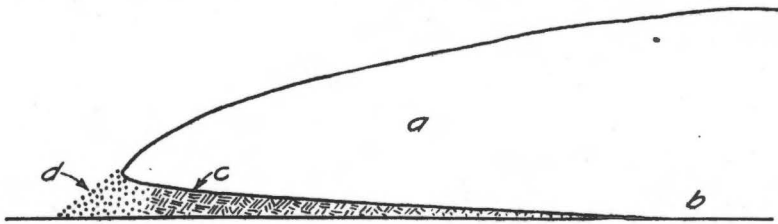

Fig. 45.—Diagram showing thinning of glacier and the effect on deposition. *a*—the glacier; *b*—zone in which the power of the moving ice is such that little material can accumulate beneath it; *c*—material lodged beneath the ice, becoming more and more abundant as the thickness and power of the ice diminish; *d*—material dropped from the ice by melting at its edge.

from farther north are smaller in proportion to the distance. It is fair to estimate that, of the drift thus deposited on the southern border of any county in southern Ohio, one-half the material came from that county itself, or at any rate from the last two counties passed over by the ice. Farther north, where the glacier was more vigorous, the proportion of material from long distances is greater.

Ground moraine is made up only in part of drift carried beneath the ice. The continental glacier, where wasting, is melting not only at the top but also at the bottom, thus setting free a part of the load carried in the ice. When set free by bottom melting this also joins the ground moraine.

Material thus left by the ice generally contains much clay. Sand and stones are embedded in the clay without assortment. The stones may be of any size up to huge boulders. Some of them may be scratched or *striated*.

**Local Character.**—From the principles here stated it will be apparent that the character of the drift at any given place reflects to a considerable extent that of the rocks just passed over. This pertains

not only to the stones embedded in the drift, but to the finer matrix as well. It is sandy where the underlying rock is sandstone, clayey where the rocks have been either shale or such as to yield clay on decomposition, and calcareous where the rocks have been limestone.

The thickness of ground moraine may be anything from a sprinkling to more than 100 feet. Throughout much of northeastern United States the total thickness of the drift is greater than this, but made up of several sheets of ground moraine laid down in different epochs. Very great thicknesses of drift (say 400 to 800 feet) are apt to be the result of other processes described below under the head of terminal moraine.

**Topography of Ground Moraine.**—The topography of ground moraine is apt to show the effect of the ice movement over it. The result will depend on the amount of glacial erosion and the amount of deposition. There is always a *tendency* to obliterate former valleys or to fill them irregularly, causing shallow undrained basins which retain lakes and swamps. If the glacier be weak and the deposit thin, as was the case in this area, the pre-glacial valleys may be little changed, and there may be neither lakes nor swamps. A very thick deposit may reduce the country almost to a plain as around Columbus, O., and the resulting streams may have nothing to do with pre-glacial valleys. Elsewhere, as in central New York, pre-glacial valleys may be obstructed and lakes result. In all cases there is a lack of angular topographic features.

#### *Terminal Moraine*

**Ridge at the Ice Front.**—Deposits made at the edge of the ice cover much less area than that of the ground moraine but are locally much more prominent. When the on-coming glacier melts at the edge as fast as it advances, the debris which it carries in, on, and below the ice, comes to rest. If the edge of the ice remains on the same line for many years this material accumulates in a ridge called terminal moraine. In exceptional cases such ridges are several hundred feet high and only a fraction of a mile wide, but smaller altitudes and greater widths are more common.

**Modes of Deposit.**—The most evident factor in the growth of terminal moraine is the mere dumping of rock debris as the ice which carried it melts. Another factor is the depositing of material carried to the front by glacial waters. These, either on or under the ice, are apt to run in narrow channels, but spread out at the edge of the ice losing their velocity and depositing their load in corners or recesses, or merely against the edge of the ice. When the latter melts away these deposits are left as mere piles of sand and gravel (kames) within the zone of terminal moraine of which they form a part. Sometimes the ice front, in its alternate recession and advance, pushes up into a steep ridge the material which lies in the way of its advance. A less

simple and noticeable, but very important factor, is the lodging of debris below the ice as it rapidly thins by melting both above and below within the last mile or very few miles from the edge. This is only an accentuation of the same process already described in the deposit of ground moraine on page 107, and illustrated by figure 45, page 107, but the thinning of the glacier near its edge is so rapid that the accumulation below begins somewhat abruptly to thicken at a rapid rate, thus building up a slope on the back of the ridge of terminal moraine. When pronounced, such a slope is commonly regarded as the back slope of the terminal moraine, though it is not sharply differentiated from the ground moraine.<sup>1</sup>

**Topography of Terminal Moraine.**—All these processes, except the last, tend to give the terminal moraine a different style of surface

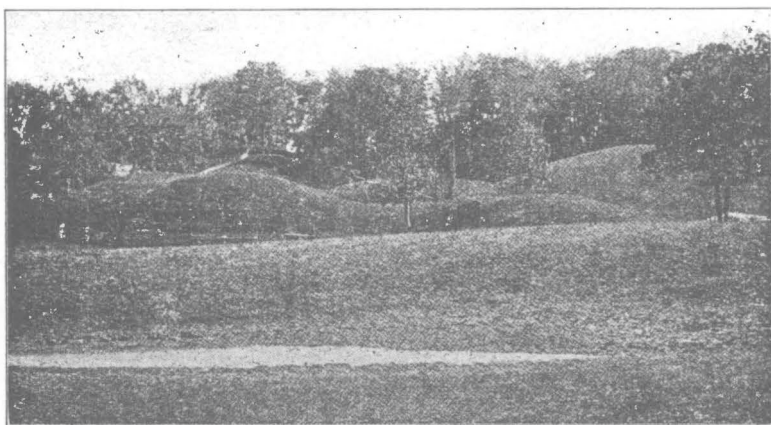

Fig. 46.—Kames near Oconomowoc, Wis. Similar topography is found in the kame districts around Camp Hageman and Furmandale.

from the ground moraine. The surface of the latter is dominated by the effect of the ice in passing over it. Its whole surface must be thought of as conforming to a moving sheet of ice. The surface of the land (omitting subsequent erosion) must also be thought of as the under surface of a moving ice sheet. On the other hand, the dominating factor in the topography of the terminal moraine is gravity acting on mere fortuitous dumps or piles of drift. This statement does not apply to the kind of back slope just described, but even on such a slope the hills and hollows are less orderly and more abrupt than in the ground moraine because of the abundance of the deposit and the diminishing power of the ice. Fig. 46, though representing the work of water rather than of ice, gives a good idea of morainic topography.

<sup>1</sup>This analysis of the processes concerned in building moraine follows Chamberlin. See *Compte Rendu of the Fifth Session of the International Congress of Geologists, Washington, 1891*, pp. 176-192.

**Drift Sheets Without Terminal Moraine.**—The description here given of the making of a terminal moraine implies a glacier (or ice-sheet) moving with considerable vigor and transporting much material to the limits of its advance. Most of the continental glaciers in North America built little or no terminal moraine. Such is the case with the first one which visited this area and crossed the Ohio. Apparently in such cases the movement was feeble and the ice thinned very gradually to its edge, so that all its load was spread out in a sheet before the edge was reached. The same effect would be produced if the ice were pushed forward to its extreme limit one or more times and then remained stagnant, or, if the ice itself continued to advance, the edge may have begun at once to retreat by excessive melting. In any case there was no constantly advancing debris-laden sheet with its edge remaining stationary.

The sheet which later covered the northern part of the area, while making no well defined ridges of terminal moraine here, made some deposits with the typically morainic topography. These are described in a later chapter.

#### *Water-Laid Drift Deposits Beyond the Glacier*

Only a part of the debris carried by the ice is dropped at once into its place when the ice melts. The balance is carried farther by the water which results from the melting ice or which falls regularly as rain. This glacial debris, rehandled and redeposited by water is built into various topographic features according to the slopes of the land where the glacier ends.

**Outwash Plains.**—If the glacier ends on flat ground, each stream which runs down its sloping surface to its edge will lose its power on reaching the edge and deposit its load in an alluvial fan. If the load be at all abundant such alluvial fans will soon grow laterally until they merge and all together form but a single gentle slope away from the ice, it may be for five or ten miles or even farther. This is called an outwash plain and is not well illustrated in this area for the simple reason that there was little flat ground where the glaciers ended.

**Lake Deposits.**—If the glacier ended on a surface of valleys and ridges in such a way that the local drainage was toward the ice, local lakes were formed, one shore of which was ice. In these lakes deltas were formed, or, in some cases, the lakes were entirely filled with sediment. Banklick Creek in Colerain Township, Hamilton County, was thus dammed. So also were the West Fork of Mill Creek two miles southwest of Glendale, and Sharon Creek one and one-half miles above Sharonville. (See p. 158.) In all these cases deep deposits of lacustrine

silt were made. The several streams have now cut down through these sediments; exposing their beds to view. They have been in part removed by erosion; their remnants constitute terraces.

**Valley Trains.**—If the glacier ended on a surface having valleys sloping from the ice, the detritus was carried down stream. All such streams flowing from the ice are overloaded with detritus, so that it forms bars and shoals and natural levees, all these being forms which



Fig. 47.—Yahtse River, Alaska, overloaded with debris from a glacier and depositing it in the form of a valley train. This represents the condition of the Miami and other large valleys in this region during a part of the glacial period. (Russell, U. S. Geol. Survey.)

attend the filling of a valley by alluvium. Such valleys become filled or partly filled with alluvium which makes a flat flood plain or valley floor (Fig. 47). This process is well illustrated in the region here described where the great valleys leading south were filled to the level now represented by terraces. The most prominent of these is that on which the business section of Cincinnati is built. Such outwash is called a *valley train* and consists of sand and gravel.

## CHAPTER VI

# HISTORY OF THE PRESENT SURFACE<sup>1</sup>

### PRE-GLACIAL TIME

**Final Rise Above the Sea.**—From the account given in a former chapter of the making of the bed rocks in this area it is seen that the area was sea bottom most of the time until sometime in the Silurian period. If it remained longer beneath the sea, or was again submerged later, the beds thus formed have since been eroded away and the record lost.

**The Making of the Peneplain.**—The history of the making of the present surface begins with the final uplift above the sea. It is not probable that the land in this region ever rose very high. Erosion reduced it again to a peneplain, that is to a nearly flat surface very near to sea level. Whether this occurred once or many times cannot now be told, for in the last complete cycle of erosion the records of all former cycles were necessarily obliterated. The last peneplain produced was at least as flat as the flattest uplands now surviving and probably not more than 200 or 300 feet above the sea. The streams of that time meandered with very little fall over very wide flood plains. The surface then, as now, was independent of rock structure, though since the rocks are very nearly horizontal the surface was very nearly parallel to the beds. Nevertheless it cuts across the beds at a very small angle. As seen on the geologic map this surface rests now on one formation, now on another. This slight discordance of surface and bedding is one of the indications that the present surface is a peneplain and not an original sea bottom which has been lifted up and not eroded.

**Age of the Peneplain.**—This peneplain was complete at some time not very long before the glacial epoch, that is, in the Tertiary period. If it was complete earlier than that it continued unchanged into the Tertiary for want of any uplift, which would give the streams renewed cutting power, and thus bring about the destruction of the peneplain.

**Uplift and Erosion.**—Later, this peneplain was uplifted. This must have been late in Tertiary time, because the amount of erosion following the uplift was not great as compared with the entire task of base leveling. In the new cycle of erosion, maturity was reached only near the larger streams. Back a few miles from them the uplifted

---

<sup>1</sup>Published by permission of the Director of the United States Geological Survey.

penplain was preserved in considerable patches. Despite the later events of physiographic history these remnants still survive at altitudes about 900 feet above the sea, being 250 to 300 feet above the Miami near Hamilton, and 350 to 450 feet above the Ohio in the southern part of the area. Remnants of the old penplain rising to a common level are sufficiently numerous so that in any extended view from one of these uplands the horizon is flat.

*Pre-Glacial Drainage Described*

**Miami River.**—Three streams of considerable importance united their waters in this area (Fig. 48). Probably the largest was the pre-

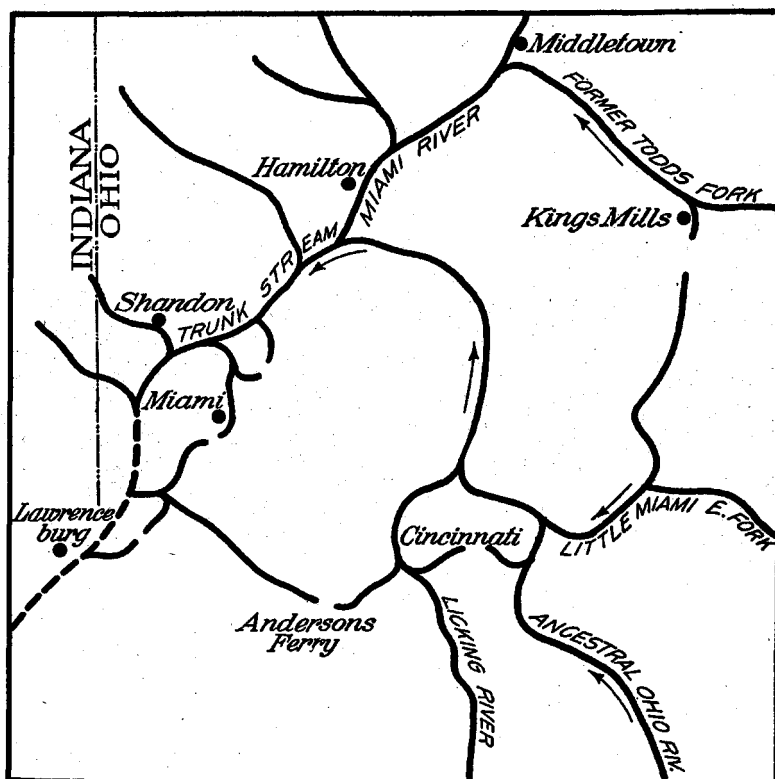

Fig. 48.—Pre-glacial drainage in the Cincinnati-Hamilton area. Compare Fig. 4, p. 25.

glacial Miami. The name must be used with reserve, since the outlines of the drainage basin and even the course of its northern portion were different then from now. But for most of the distance from Dayton to Venice, Ohio, the pre-glacial stream followed nearly the course of the present Miami.

**East Fork of Little Miami River.**—Another stream entered the area from the east along the line of the East Fork of the Little Miami and flowed west past Madisonville and Norwood. Judged by the breadth of its valley it was smaller than the Miami, but quite as large if not larger than the stream which entered the area along the line of the present Ohio.

**Licking River.**—From the south came the ancestral Licking, essentially in its present valley, with this exception that it continued northward through the Cincinnati basin and the narrow part of Mill Creek Valley to near Elmwood Place. There it joined the stream from the east, the ancestral Ohio described below. It thus appears that the broad and now very important Cincinnati basin was not made by the great river which now traverses it, but by the relatively small Licking, which, both south and north of this basin, flowed in a much narrower trench, having an almost constant width of one-half mile. It is quite probable that this and several other local expansions of the old river troughs are due to certain structural weaknesses of the rocks which made erosion easy.

**Ohio River.**—The stream which entered the area along the line of the present Ohio probably headed near Manchester, Ohio, not more than seventy miles above Cincinnati. If this stream be called the pre-glacial or ancestral Ohio it must be understood that it is so called purely on account of its course in this vicinity, and with the understanding that there was no Ohio River then in the sense of a stream having the same drainage basin as the present Ohio. This stream turned northeast at California through the valley now occupied by the Little Miami. South of Madisonville it was joined by East Fork and together these waters flowed west through the Norwood trough to what is now Mill Creek Valley.

After this stream from the east had united near Elmwood Place with the Licking from the south, the combined stream flowed north through what is now Mill Creek Valley and, turning west in the same valley, joined the Miami about three miles south of Hamilton. Passing southwest from there past Venice, the master stream flowed through the broad valley described in Chapter I as the New Haven trough. This valley is the natural continuation of the Miami, not only in direction but in dimensions and in the style of its bluffs, whereas the narrow trenches past New Baltimore and Miamitown agree in none of these. Near Harrison this master stream turned and flowed south through what is now the Whitewater Valley, a valley which plainly was made by a larger stream than the one which now occupies it.

**Todd's Fork.**—Still another large stream crossed the northeast corner of the area, joining the Miami at or near Middletown. This stream made and occupied the large valley described in Chapter I as the Union Village trough. When traced headward this trough is



seen to be continuous with the valley of the Little Miami from Morrow to South Lebanon, and, east of Morrow, with the valley of Todd's Fork. In pre-glacial time a continuous stream flowed along this line from the valley of Todd's Fork past Morrow, South Lebanon, Camp Hageman, and Union Village, joining the Miami at Middletown.

**Tributary Streams.**—Most of the principal tributary streams occupied the same valleys then as now. This is true of Sevenmile, Fourmile, and Indian creeks. All these streams, small and large, flowed at levels from 50 to 150 feet below their present channels, as indicated by the depth of the bed rock surface below the glacial drift and alluvium.

A number of tributary streams, very important in the history of the drainage, but no longer in existence, are shown on the map (Fig. 48, p. 113). One of these flowed north from Foster at the eastern edge of the map. It followed the line of the present Little Miami (reversed) and discharged into the pre-glacial Todd's Fork near King's Mills. Another flowed south from Foster to Milford along the present course of the Little Miami, but it was then a small tributary of the East Fork. Near Foster, perhaps just south of it, the north-flowing and the south-flowing streams were in headwater opposition and had cut a notch or col in the upland.

Another pair of tributaries, which later became of great importance, flowed east and west from near Dayton, Ky., along the line of the present Ohio; the one being tributary to the former Ohio, the other to the Licking. There was also a sag or col or notch in the upland between their heads.

In similar manner another pair of small streams flowed north and south from the col one and one-half miles south of Miamitown. The south-flowing stream followed the course of the present Miami and joined the master stream near the present mouth of the Whitewater. The north-flowing stream flowed eight or ten miles to join the master stream between Shandon and Fernald. It probably received a small eastern tributary from near New Baltimore, and it is certain that another small stream flowed east and north from New Baltimore along the line of the Miami (reversed) to join the master stream.

The Dry Fork of the Whitewater, which now flows south on the western edge of the area past Shaker Village and New Haven, formerly turned east to Shandon through the valley now followed by the C. & O. Railroad, and then south through what is now the valley of Paddy's Run to the master stream.

A small stream heading near Mount Hope Church, two and one-half miles north of Miamitown, flowed northwest joining the master stream west of New Haven.

Another pair of tributaries, which later came into great importance, flowed east and west from a divide just east of Andersons Ferry. The east-flowing one joined Licking River near Ludlow, Ky. The west-

flowing stream joined the master stream west of Cleves, following the present course of the Ohio only so far as North Bend, there turning north and then west in a course not very different from that of the Big Four Railroad. Thus it joined the main stream near Valley Junction on the north side of the isolated upland. Where the Ohio now skirts the southeast edge of this upland there was then a minor divide where two small streams headed, one flowing northeast to join the stream just described at North Bend, the other flowing southwest to join the main stream near Lawrenceburg. The stream which flowed from Andersons Ferry past North Bend received, west of Cleves, the northern tributary described above as heading at the divide south of Miamitown.

*How This Former Drainage System is Known*

The evidences by which it is known that the streams were as here described, naturally divide themselves into two classes, those which go to show that the large streams did *not* have their present courses and those which go to show that they *did* have the courses described. Speaking first of the former:

**Narrows at Andersons Ferry.**—A group of features showing that the Ohio has not followed its present course very long is found at or near Andersons Ferry. The bottom of the narrow trench at that place is scarcely wider than the river in high water (see Pl. I-A, p. 24). The bluffs here are exceptionally steep and, as pointed out in Chapter I, the south bluff for three miles east of the Ferry is almost free from ravines or even gullies. These features indicate a very young gorge. The trench of the Ohio elsewhere has at least from two to four times the width of the river. Even this is not old, but the actual time required to cut a trench twice the width of the river is much more than twice, perhaps many times the time required to cut a gorge as wide as the river. A large stream may cut a gorge of its own width in a relatively short time; this is all done by down-cutting, but the widening of a trench is by very different processes which do not work so rapidly.

It is a general principle that tributaries soon become numerous and the upland soon dissected in the immediate vicinity of a great down-cutting river, but the opposite is the case here. Immediately south of the river lies a broad upland sloping from the river, and almost the same feature is seen on the north side. The undissected character goes to show that until recently these uplands were remote from master streams. It is this exceptional circumstance which accounts for the commanding character of the sites occupied by the two convents on opposite bluffs, Villa Madonna on the south and St. Joseph Mothers' Home on the north.

If the character of this gorge be contrasted with that of the Miami trench or that of the Little Miami below Milford or with Mill Creek

Valley (see Figs. 6-12, p. 28, and maps in pocket), it will be seen that these latter are not only from three to six times as wide but that their bluffs are much eroded and there are no broad uplands near these valleys. The actual time necessary to cut these valleys is not three nor six, but many times that which would be necessary to cut the gorge at Andersons Ferry.

The evidences of youth are of the same class, though generally less pronounced, at all the other places which were described above

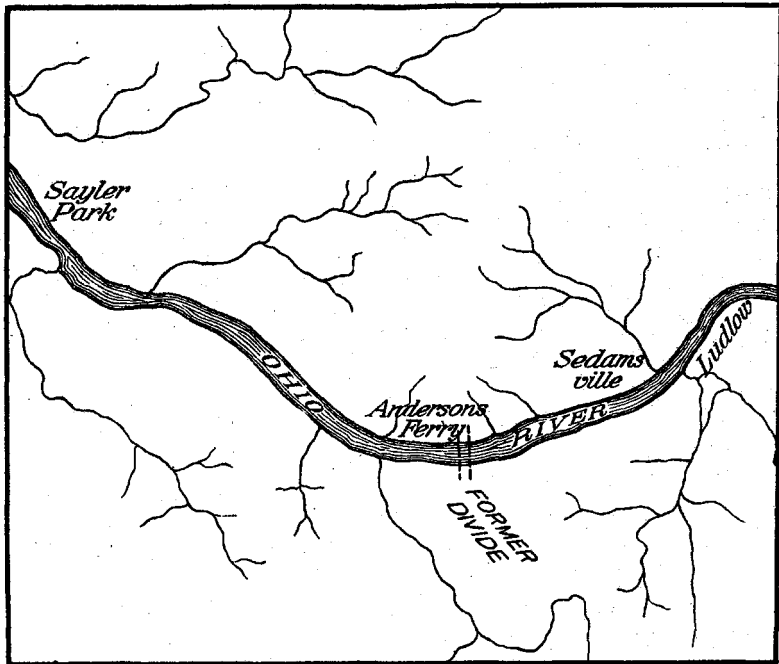

Fig. 49.—Map showing direction of tributaries to the Ohio, east and west of Andersons Ferry. These tributaries were developed when small streams flowed east and west from near Andersons Ferry. Compare Fig. 48, p. 113.

as cols or divides from which two former small streams were said to have flowed in opposite directions along the line of the present large streams. The narrows between Dayton, Ky., and Walnut Hills, and the similar narrows below North Bend are less striking in character. So also is the one at New Baltimore on the Miami, but the one south of Miamitown almost rivals the gorge at Sedansville.

**Narrows of the Little Miami.**—The evidence of this character derived from the Little Miami is very striking. The features of the gorge at Foster are essentially those described at Andersons Ferry, though of smaller dimensions. No observer of valleys could possibly

fail to note the peculiarity of the Little Miami, flowing as it does from its spacious valley at South Lebanon into the gorge south of Kings Mills, and later into the broad flat south of Milford.

**Direction of Tributaries.**—Another class of evidence going to show that the large streams did not follow their present courses is found in the direction of some of their tributaries. Streams commonly join at an acute angle. It is exceptional or abnormal if the angle between the two streams *above the junction* is obtuse. In that case the tributary must to a considerable degree turn back on its own course. Such an exception or abnormality is very striking between Andersons Ferry and Ludlow, Ky. Tributary streams on both sides of the Ohio enter at very obtuse angles and turn back on their own courses (Fig. 49, p. 117), indicating that they were normally tributary to an east-flowing stream. West of Andersons Ferry all tributaries join normally.

**Character of the Old Valleys.**—Having now considered the features which indicate that the large streams did not have their present courses in pre-glacial time, it remains to point out those features which indicate that the streams were as shown in figure 48, page 113. Of the evidence that the former large streams did have the courses described above, the most striking consists in the great valleys themselves. This is especially convincing where the great valleys are not in use at present by any through-flowing stream, for example, the Norwood trough, the New Haven trough, the Mill Creek Valley west of Flockton and the Union Village trough. (See Fig. 4, page 25.) That such great valleys should be directly connected with present river valleys, continuous as to direction, dimensions, and character, is strong evidence that they were made at the same time and in the same way. This is especially convincing where the stream in leaving the continuous valley turns into a narrow and evidently young trench.

**Slope of the Bed Rock Surface.**—In determining the direction of former drainage, the final appeal must be to the altitude of the bed rock surface along the lines in question. If rivers flowed in the courses assumed, and made the valleys in question, the valley floors must have sloped in the direction indicated. If filled later by loose material the slope should still be preserved on the surface of the underlying rock. It is difficult to ascertain this in detail. Our knowledge of the form of the bed rock surface comes largely from deep wells, piers, etc. From many deep wells drilled in and near Cincinnati, it appears that the surface of the underlying rock between the bluffs is not far from flat. No part is known to be more than seventy feet below the level of low water, possibly seventy-three feet in one case or 357 feet above sea level. The well in which bed rock was presumably found at this depth is located at the gas works on the river front. A well at Lockland (Stearns and Foster Paper Mill) struck rock at a level of only 356 feet above the sea. At Hamilton one of the wells of the city water works struck rock at a depth of 208 feet or 360 feet above the sea.

The above named depths are so much alike that it cannot be stated with certainty from this evidence which way the rock surface slopes between Hamilton and Cincinnati. Future wells at either place might reveal lower depths, but this is more likely at or near Hamilton than near Cincinnati, because the large amount of drilling already done at the latter place leaves less chance of discovering the rock surface at greater depths.

North of Hamilton, there is no question that the rock surface inclines southward almost as much as the river falls. The lowest surface reached by wells at Middletown is 410 feet above the sea and the lowest at Dayton 508 feet. At St. Paris, in Champaign County, a well drilled for gas went through 530 feet of drift without reaching bed rock, but even at that depth the bottom of the well was more than 700 feet above the sea. The conclusion may therefore be accepted that the drainage in pre-glacial times was southward toward Hamilton.

Unfortunately, for many miles down the Miami below Hamilton, there have been few deep wells drilled, and none deep enough to reach the rock. At Lawrenceburg, Ind., rock was encountered at an altitude of 365 feet above the sea, but that was not in the middle of the valley. The rock surface in the axis of the valley may be considerably deeper. So far as it concerns the area here treated, the chief conclusions to be drawn from the slopes of the rock surface are that such evidence is nowhere adverse to the plan of pre-glacial drainage as determined by topographic features, and that north of Hamilton the evidence is clear and positive.

#### THE ILLINOIAN GLACIAL STAGE

The description above given of topography and streams depicts the country at a time just previous to the first ice invasion. The first glacier to reach this area was not the first which invaded the United States. It may have been the third. It is called the Illinoian because it practically covered Illinois, and throughout most of that state the drift sheet which it left was not itself covered by that of a later glacial stage. This Illinoian ice sheet came, in a general way, from the north, but the exact direction cannot be told because few scratches or "striations" made at this time are left on the bed rock of this region. Near Newkirk, on the line of the Chesapeake & Ohio Railroad, about ten miles west from Hamilton, the bed rock is found smoothed and striated. Specimens were collected from this locality by Dr. George Twitchell of Cincinnati, who reports their direction as decidedly east of south. Dr. Twitchell also reports smoothed and striated rock surfaces on the bluff south of Excello. It will be observed that the bluff at this place is in the form of a wedge pointing north, and was, therefore, peculiarly exposed to the force of the southward moving ice.

*Drainage Changes Due to Glaciation*

**Effect of Outwash Before the Glacier Arrived.**—With the advance of the ice sheet from the north, the system of drainage above outlined began to be disturbed. Even before the ice reached Middletown, when it entered the upper basin of the Miami, the effect began to be felt in this area. No doubt the Miami quickly became an overloaded stream like other streams which receive drainage from glaciers. Its valley began to fill up with sand and gravel. Some of the sand and gravel now resting on the bed rock beneath the present streams may have been laid down at that time and never since disturbed. The partial filling of the Miami Valley raised the outlets and checked the currents of all its lower tributaries. They must then have begun to deposit sediment. If the deposits of each stage could be separated from all others and recognized, it would doubtless be found that some of the sand and clay passed through in drilling wells in Mill Creek Valley, the Norwood trough, and the Union Village trough were dropped at that time from the slackened waters of the ancestral Ohio and Todd's Fork.

**Changes in Todd's Fork and Little Miami.**—When the glacier reached the bluff at Excello, south of Middletown, the current of Todd's Fork was stopped, and its waters backed up in a lake. On the bottom of this lake there settled mud brought down by the stream, and mud with coarser sediments washed out from the ice. These lacustrine sediments covered the alluvial sediments deposited when the current was first slackened. It is not now possible to separate them. Later, however, when the ice advanced farther, a sheet of boulder clay was laid down on top of the alluvial and lacustrine sediments. A well one mile south of Union Village pierced twenty-eight feet of such boulder clay between the depths of 102 and 130 feet. Between this boulder clay and the underlying limestone were found three feet of gravel. No alluvial or lacustrine clay was identified at this place.

The ponding and rising of the water in this valley caused it to back up its tributaries and at length to overflow the divide at Foster. The whole Little Miami was later buried by ice, but before the ice again disappeared from the mouth of this valley at Middletown the new gorge at Foster had been cut so deep that the waters could not resume their old course. Thus Todd's Fork became the upper course of the Little Miami, or, it may be said, the Little Miami came into existence at that time. The lower valley of Todd's Fork was left without a stream. During the retreat of the ice front when the glacier again blocked the outlet near Middletown, there may again have been a lake in this valley, and in this lake clay would have been laid down on top of the sheet of till. Such clay is found in great abundance. The well mentioned

<sup>1</sup>See Bownocker, J. A.—History of the Little Miami; Ohio State Acad. Sci. Special Paper No. 3, pp. 32-45, 1900.

above is said to have passed through nothing but gummy clay between the depths of 6 to 102 feet. A well at the canning factory at Camp Hageman went sixty feet through the same "gummy clay," finding gravel below. It is not possible to say how much of this was laid down in the lake which existed during the retreat of the first ice sheet and how much in the similar lake which may have existed during the advance of the second ice sheet. It is quite probable also that somewhere in that ninety-six feet of "gummy clay" is a sheet of till not detected by the drillers, which was laid down by the second ice sheet, only to be again covered by lacustrine clays laid down during the wasting of that sheet, but before it was melted away from the mouth of the valley below Middletown. At Oakland there are seventeen feet of till just beneath the soil, and near Middletown several square miles of the valley floor are underlain by till. These sheets, at least, were deposited during the later ice stage, and rose above the level of any lakes which may have existed during the last retreat of the ice.

It may occur to the reader that if the drainage changes resulting in the formation of the Little Miami were thoroughly established before the retreat of the first ice sheet, there was no occasion for any later lake in this valley, or at least not in that portion of it which drained toward the newly formed Little Miami. Yet the large amount of fine clay which forms the larger part of the valley floor and, in part at least, overlies the later drift, shows that the valley must have held standing water, even as late as the retreat of the second ice sheet. The reason for this last lake is no doubt found in the great deposit of kame gravels which cross the valley near its southeast end. If lakes also existed during the retreat of the first ice sheet and the advance of the second, these may be explained by assuming that the valley was similarly obstructed by deposits of the first glacial stage.

**The Cut-Off at Andersons Ferry.**—As the ice advanced nearer and nearer to the junction of the former Miami and former Ohio, just south of Hamilton, the current of the latter stream was more and more checked by detrital filling at its mouth. Eventually when the ice itself had crossed its mouth, perhaps after advancing a considerable distance to the south, the current of the former Ohio was stopped and its waters rose in a lake. As in all similar cases there were sediments in this lake derived partly from the inflowing stream and (near the ice) from glacial outwash. The latter would be distinguished by some admixture of feldspar and other minerals from the igneous rocks of Canada, but, except for that, it will probably remain impossible to differentiate these lacustrine sediments from those river sediments which were deposited during the slackening of the current. In any case, clay, sand, and some gravel would be deposited during the advance of the ice, and these would later be covered by a sheet of till when the ice passed over. This agrees with the data obtained from drilled wells.

It is possible that by the time the ice reached Lockland the valley had been filled to a height of 500 feet above the sea, for no till is well authenticated at a lower depth. Farther north the glacier arrived earlier, before the valley had been so deeply filled. The wells of the Glendale Waterworks encountered some till down to the level of 472 feet above the sea; beneath that level was found mainly sand.

The impounded waters in this valley necessarily rose until they found an outlet. Probably for a considerable time they flowed along the edge of the ice when it stood against the bluff south of Symmes Corners. This probably accounts for the fine steep bluff west of that point. This bluff has almost no gullies and bears all the appearance of youth. Its youthful appearance may have been again renewed in like manner during the later glacial stage.

When the water could no longer escape by following the edge of the ice, it rose until it crossed the divide between the headwaters of the small streams at Andersons Ferry. When the ice finally retired, leaving the old valley partly filled with drift, this notch was already cut so deep that the stream failed to resume its former course.

**Changes in the Miami.**—Miami River can scarcely be said to have existed while the glacier covered Butler County, its entire drainage basin being covered by ice. The drainage from this area no doubt gave rise to many streams running over the ice and leaving its front at different points. Some drainage may also have followed the present river valley beneath the ice. After the glacier filled the valley west of Venice, the immediate drainage from the ice necessarily chose the lowest course it could find among the hills to the south. For a time this lay along the present course of the Miami through the narrows past New Baltimore and south of Miamitown. This line was marked out by the small pre-glacial streams described on page 115, and shown in figure 48, page 113. On the disappearance of the ice this line of escape for glacial waters became the permanent channel for the Miami, because the old valley west of Venice had been partly filled by glacial drift.

It is not probable, however, that the new channel past New Baltimore and Miamitown was cut down entirely by waters coming from the glacier. As pointed out above, it is probable that when the ice front stood some four or five miles south of Hamilton, the waters of the ancestral Ohio escaped westward for some time between the ice on the north and the bluff on the south. This condition may well have continued for some time after the Miami Valley further west was completely obstructed. If so, the entire volume of the master stream was available for some time to assist the cutting of the new valley past New Baltimore and Miamitown. Judging from the size of the present Miami Valley in that section it is quite probable that its cutting was thus helped by the stream from the east, at a time when the drainage of the Miami basin was dissipated and relatively ineffective.



**Other Cut-Offs by the Ohio.**—Later still the glacier reached the highland west of North Bend and again dammed the main stream, which by this time was flowing past Andersons Ferry, but turning north at North Bend and then west at Cleves. By this obstruction the Ohio was again ponded, and its waters rose until they crossed the notch between headwaters southwest of North Bend along the line of the present Ohio.

Whether before or after this event, the ice reached the bluff south of St. Bernard. Previous to that it is probable that all the water of the Ohio and Little Miami flowed around to the north of Cincinnati through what is now the Norwood trough. When the ice reached the upland of Cincinnati the water rose above the col or notch opposite Dayton, Ky., and flowed directly west, thus completing the present course of the Ohio.

**Changes in Dry Fork.**—At an early stage in the advance of the ice the former valley of the Dry Fork of the Whitewater was obstructed west and south of Shandon. That stream then crossed the highland straight to the south toward the Shaker Village. That portion of the valley west of Shandon was filled with till to a height of more than 660 feet above the sea. It is not known how much of this belongs to the first glacial stage and how much to the second. This filling is at least 112 feet deep, as known from a well near the center of the valley. It may extend much deeper, since bed rock was not reached. A well farther west, and belonging to Mr. T. Schradin, is only about one-eighth mile east of the present stream, and started thirty feet above the stream level. The record of material passed through in drilling this well corroborates the account of drainage changes here given. The material is as follows:

*Record of Well Two Miles West of Shandon, Ohio*

	Feet.
1. Till with few stones, down at least to the level of Dry Fork, as noted in bluffs near by; at least.....	30
2. Fine, light-colored clay, to.....	65
3. Same with vegetable remains, well preserved, including 10 feet of good peat, to.....	88
4. Quicksand.	

The till at the top is that of the later glacial stage, and shows that the fine clay was deposited as the result of an earlier obstruction. The fine clay represents lake filling, and the peat may have accumulated either on the bottom of the lake or (more probably) in a depression on an old flood plain.

Where the stream crossed the upland to the south it now flows in a narrow steep valley more than 120 feet deep, and possibly 100 yards wide at the bottom. At places its lower ten or twelve feet are cut in rock. How much of a notch the stream found in the upland along

this new course cannot be told. It may have been enough so that the drift alone in the valley to the east was sufficient to turn the stream in this direction. Otherwise, it would be necessary to assume that the ice either blocked the old valley before it reached the new or remained in the old valley longer.

### *The Older Glaciation on the Uplands*

**Thickness of the Till.**—The deposit of till on the uplands varies from almost nothing to a thickness of ten or fifteen feet. Thicker deposits are generally confined to valleys and ravines. The average thickness, aside from the broad valleys, may be from one to five feet near the Ohio, and from eight to twelve feet near the Hamilton-Butler County line. This applies to the area not covered by the later drift sheet. Farther north, where it is overlain by the younger till sheet, its thickness is hard to estimate because of the difficulty in distinguishing the two formations. In the more hilly sections bordering the Miami Valley from Venice to Lawrenceburg, this drift is almost as thin as on the bluffs of the Ohio.

**Character of the Till.**—The Illinoian till is generally a hard blue clay (yellow near the surface), containing many fragments of limestone. These fragments are generally small, many good exposures showing no fragments larger than one or two inches. However, fragments the size of a hand are common, and the dimensions may reach a foot or more. The majority of these fragments are of blue limestone, being from the same formations as those which underlie the area. Many others are of light-colored limestone, such as underlies western Ohio and eastern Indiana farther north. A very few, perhaps one or two per cent, are of igneous rocks, granite, basalt, etc., and metamorphic rocks, gneiss, quartzite, etc., derived from north of the Great Lakes. But although such stone are rare in the drift, the few large bowlders which are found on the surface are nearly all of this character.

This till or bowlder clay is generally very hard. It cannot be shoveled, even where free from large stones, and offers considerable resistance to a pick. It is generally very calcareous, effervescing freely with weak muriatic acid. In such tests, the limestones must of course be avoided. This calcareous quality is absent only within a foot or so of the surface, where the lime has been leached out in the process of weathering.

Another surface phenomenon in the till is a change of color from blue (generally very pronounced) to yellow. This is due to the complete oxidation of the iron as in case of our local limestones (see p. 73). This oxidation generally goes down from five to ten feet, and may go farther. The oxidized till retains its calcareous nature except very near the surface.

Another feature of this till consists in the prominent cracks which are sometimes seen to traverse it in fortuitous directions where freshly exposed in the bank of a stream. In many cases water is seen oozing from these cracks, and along all of them the clay is completely oxidized for an inch or more on both sides.

**Southern Limit of the Drift.**—The exact southern boundary of the drift is hard to determine because of its thinning and gradual disappearance. It is thin or absent on the steeper bluffs of both the Ohio and the Miami. There are few good exposures in Kentucky, but, on the other hand, there are few large areas without some trace of glacial deposit. Wright reports twelve feet of till one mile east of Hebron,<sup>1</sup> and there are small exposures in the cuts along the Fort Mitchell car line southwest from Covington. Gullies from two to five feet deep are regrettably common on the steeper slopes, and in the bottoms of these it is not uncommon to find a few igneous or metamorphic stones of Canadian origin. Where a few of such are found it is safe to assume that many more limestones were also left by the glacier, but are not always distinguishable from the residual fragments in the mantle rock.

An easier but less accurate method of determining the limits of the former ice sheet is by means of foreign boulders found in creek beds. It is a fair assumption that such boulders came from the drainage basin of the stream in which they are found. If the stream is flowing toward the north, then the local limit of glaciation is at least as far south as the boulders. Practically all of the small streams and ravines in the southwestern part of this area, west of Banklick Creek, Ky., contain some foreign boulders. Gunpowder Creek at and beyond the southern margin is no exception. Some of these may have been carried south by this creek beyond the point where they were dropped by the ice, but that could not have been the case with the boulders found in the small tributary ravines. The bed of Bullock Pen Creek, which flows eastward to the Banklick from Florence, Ky., just south of the limits of this area, has many large crystalline boulders, some of them three or four feet in diameter. Probably the ice reached at least that far south. The area between Banklick Creek and the Licking has furnished a few foreign stones as much as five or six inches long. It is not improbable that the ice covered at least its northern part. Similar evidence seems to indicate that the ice invaded the northern end of Campbell County, Ky., perhaps as far south as Fort Thomas. In the small streams and ravines of the south bluff of the Ohio east of Fourmile Creek, foreign stones are somewhat plentiful.

**Topographic Effect.**—South of the Ohio and for a few miles to the north, no topographic changes due to glacial agency can be detected

<sup>1</sup>Wright, G. F., *The Glacial Boundary in Western Pennsylvania, Ohio, Kentucky, Indiana, and Illinois*. Bull. U. S. Geol. Survey No. 58, p. 64, 1890.

except such as result from the drainage changes already described. Even near the Hamilton-Butler County line the present valleys and even the larger ravines seem all to be of pre-glacial origin, indicating that the drift deposit was too thin to obscure them. The general surface seems to have been coated with drift over hill and valley alike and it remains so to the present except in the channels of some streams and on some of the steeper and more exposed slopes.

### *Inferences as to Behavior of the Ice Sheet*

From this description of the character and distribution of the drift, and the topographic effects of the ice invasion, some things may be inferred concerning the general character of the glacier and its behavior.

**Thickness of the Ice.**—It is a fair inference that the ice on the uplands was everywhere thin. Otherwise there would have been at least local erosion and striation of the underlying rocks. Till was deposited without erosion, not only on weathered rocks but on laminated sands and clays in the valleys. This can be seen in the fine section along the Pennsylvania Railroad between Claire Station and Shade-more, and again in the bluff one mile north of California. It may well be that in these cases the ground over which the ice advanced was frozen, but the facts are none the less noteworthy as showing a contrast in behavior between the ice which moved over our soil-mantled hills and that which plowed the great furrows in the massive limestone of Kelleys Island.

Another inference is that the ice was not only thin, but *thinning* as it advanced southward. This is inferred from the fact that there remained no drift to be deposited as terminal moraine at the limit of advance. Another inference to account for the same fact is that the ice did not remain long at the southern limit of its advance. These two assumptions support each other. The greater the stress placed on one, the less dependence need be placed on the other.

**Derivation of Its Load.**—It is clear also that the ice was handling chiefly local material. Probably one-half of all that was laid down in this area was also picked up within its limits (if that can be said to be picked up, which is merely dragged along between the ice and the earth). Probably nine-tenths of the material came from the states of Ohio and Indiana, and ninety-eight or ninety-nine per cent from south of the latitude of Lake Superior, that is, from the area of un-metamorphosed sedimentary rocks. Some of the drift near the Ohio looks as though it were residual mantle rock, slightly disrupted by the glacier, and with an occasional foreign stone dropped or pressed into it.

The glacier did indeed carry some boulders from the far north, either in the ice or on the surface, brought there by the melting of the

ice above. Because these were carried in or on the ice they traveled to its edge, and were there deposited in somewhat larger proportion than along the way. Probably no creek bed in the area of the Illinoian drift has so many large foreign bowlders as the Bullock Pen, just beyond its southern margin.

### *The Older Glaciation in the Great Valleys*

A study of the deposits left by the Illinoian ice sheet in the Mill Creek Valley, and other great valleys of the region, indicates that its behavior in these valleys differed materially from its behavior on the uplands. Three remarkable features of the drift in these great valleys are its thickness, the interstratification of till and water-laid sediments, and the terrace-like or flat-surfaced form of the deposit.

**Topography of the Valley Drift.**—Generally the glacial deposits of this age form terraces in the wide valleys, the surfaces of these terraces being approximately flat, but sloping a little from the bluffs toward the axis of the valley. Usually they abut against the bluff in a fairly abrupt manner. Locally, where the bluff is not steep or well defined, its slope merges with that of the deep glacial deposits in the valley. Where the terrace is well defined the altitude of its outer and upper edge is generally not much above 640 feet, or below 620 feet. Where the deposits are preserved in the middle of the broad valley, as in Mill Creek Valley north of St. Bernard, the slope toward the axis may carry the altitude below 600 feet, even as low as 580 feet.

**Interstratified Materials.**—At the edges of this terrace the material is locally exposed in section as low as 500 feet above the sea. As far down as exposed, bowlder clay is seen to be interstratified with the sand, gravel, and clay. At places almost the entire thickness seems to be of bowlder clay; elsewhere it is almost entirely water-laid material, but there are few places where bowlder clay does not appear at the top just beneath the soil.

The water-laid deposits in these terraces are perhaps equal in volume to the till, and hence very important. They consist of gravel, sand, and clay. The gravel is composed almost entirely of limestone pebbles, generally not more than two or three inches in diameter. The few foreign pebbles present have more importance in indicating the history of the gravel than in making its bulk.

The large amount of limestone in these gravels, and the favorable conditions for percolating water, have favored the cementation of the gravel into conglomerate. This is more especially true at the edge of a gravel terrace where ground water escapes by seepage or in springs. There the water evaporates, precipitating its carbonate of lime. In terrace fronts, therefore, these gravels are generally, at least partially, cemented, and not infrequently consolidated into a

firm conglomerate. The edge of the terrace east of California furnishes abundant illustrations. The sand beds are also locally cemented, especially in concretionary forms. It is in beds of this age that the abundant concretions referred to on page 40 occur.

The reason for the relatively flat surface of these valley deposits is suggested by the nature of the materials. Deposits by overloaded streams necessarily make a nearly level surface. The terrace-like character and striking uniformity of altitude of the drift deposits in the larger valleys are, therefore, due to the large part played by water in their making. Glacial lobes acting alone would indeed have made thick deposits in these valleys, but the surfaces of such deposits would have been more rolling. The fact that all the till in these valleys was laid down on a nearly level floor of alluvium tended to give it a level surface. The further fact that, in most places, the till was laid down in

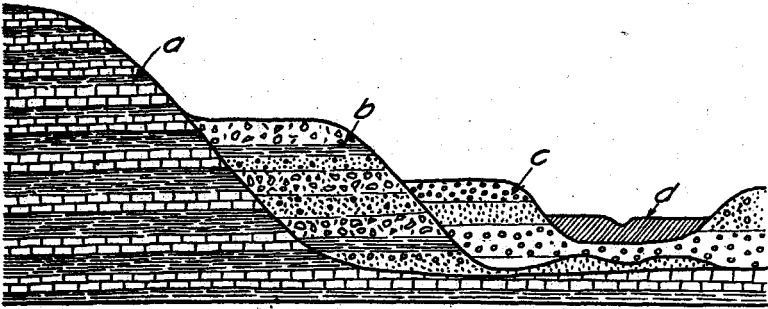

Fig. 50.—Diagrammatic representation of terraces in Mill Creek and Little Miami valleys. *a*—preglacial bluffs thinly covered with till; *b*—interbedded till and outwash of the Illinoian glacial stage; *c*—outwash of the Wisconsin glacial stage; *d*—recent alluvium.

several sheets, the surface in each interval being leveled up by water-laid sediments, tended still further to give to the final till deposit a nearly horizontal surface.

**Glacial Lobe in Mill Creek Valley.**—The great thickness of till in the broad valleys, when compared with the thin deposits on the upland, suggests not only that the ice was thicker and more powerful in these valleys than over the intervening uplands, but also that it worked for a longer time in the valleys than on the uplands. From theoretical considerations (see p. 105) it was seen that the former fact is certain, and probably the latter also.

Mill Creek Valley, whose axis is from 300 to 400 feet below the adjacent uplands, and which lies in the direction of the ice movement, was especially favorable to the formation of a glacial lobe. A tongue of ice may even have pushed down this valley in advance of the ice

when it first covered the area, but it is much more probable that the ice survived in this valley as an active part of the glacier after it had melted away from the uplands.

**Behavior Inferred from Typical Sections.**—The effects of greater power, exercised for a longer time, is seen in the thick accumulation of boulder clay at the bridge over Mill Creek, west of Carthage, on the road to College Hill. The west bank of the creek is here more than fifty feet high, showing the following section:

*Section at Bridge West of Carthage*

	Feet.
(1) Boulder clay (poorly shown in the face of the bluff).....	15
(2) Finely laminated tough brown clay.....	5
(3) Blue boulder clay.....	40
(4) Talus of till.....	5
Total.....	65

Base of section at about 510 feet above sea level.

It is not known how deep the boulder clay extends beyond the base of the section, and it is probable that the top of this section does not indicate the upper limit of the deposit before erosion.

There is no indication in this section that the deposition of boulder clay was interrupted, except at the time when the five feet of laminated clay was being deposited. Such clays *may* be deposited in quiet pools beneath the ice, but such pools would necessarily be very local. It is more probable that the ice front had temporarily receded. As seen below, the water-laid beds shown in other sections are too abundant and continuous to be easily explained without assuming that the ice occasionally melted back a considerable distance.

A quarter of a mile farther north another section exposed in the same bank is as follows:

*Section One-fourth Mile North of Bridge West of Carthage*

	Feet.
(1) Boulder clay.....	12
(2) Finely laminated brown silt.....	8
(3) Boulder clay.....	8
(4) Clean sand.....	15
(5) Boulder clay.....	30
(6) Sand.....	6
Total.....	79

Base of section at altitude of about 512 feet.

An effort to correlate these two sections shows how irregular are the deposits made by glacial waters near the edge of the ice. Making suitable allowance for the slumping of such deposits, and for error in

measurement of altitudes, it may be that numbers (1) and (2) are identical in the two sections, that is, that they represent continuous beds, the clay below showing a time of ice disappearance, and the till above representing the final advance. It is certain, however, that the fifteen feet of sand (No. 4 in the northern section) is not represented in the other section one-fourth mile to the south. This sand may have accumulated beneath the ice, or it may have been laid down in a depression in the till surface during a temporary recession, or it may have been laid down at both places during such a recession, being covered up by till and preserved in the northern locality, and eroded away by the readvancing ice (or by water in the meantime) in the southern locality. The chief importance of these two sections consists in showing, first, the general constitution of the terraces of Illinoian age and, second, the great local variation. The various assumptions here made as to the behavior of the ice and the circumstances of deposit have widespread application.

An exposure at the edge of the same terrace due east of Hartwell in the east bank of Mill Creek, but in the middle of the wide valley, is as follows:

*Section East of Hartwell*

	Feet
(1) Till (15 feet near by) actually shown in the section.....	5
(2) Dark clay very fine and gummy.....	15
(3) Till of very uniform thickness.....	5
(4) Fine sand, some of it minutely laminated.....	25
Total.....	50

Base of section at creek level about 525 feet above the sea.

In this section, again, there is reason to think that Nos. (1) and (2) are identical with the corresponding beds in the other two sections two miles farther down stream, but correlation of the sands and till sheets below is mere guess work.

The several proportions of boulder clay in the three sections are eleven-twelfths, five-eighths, and one-third. The last named of the three sections is in the middle of the broad valley, and it is not improbable that the normal proportion of water work to ice work should be greater in the middle than at the sides. All three sections agree in showing that the outwash from the Illinoian glacier in this part of the Mill Creek Valley was limited to fine material, not coarser than sand.

In its southward movement the glacial lobe in this valley came against the high hills of Avondale. The deep deposits of till, with varying amounts of interbedded sediments, built the levels on which Bond Hill and St. Bernard are situated. South of St. Bernard, and reaching within half a mile of the Zoo, extends the same level, now sharply dissected by streams of later origin. Most of the natural ex-





A.—Eroded edge of the Illinoian drift terrace, at the left; silt terrace of the Wisconsin stage at the right and lower; preglacial upland (limestone, etc.) in the background. West of Spring Grove Cemetery, Cincinnati.

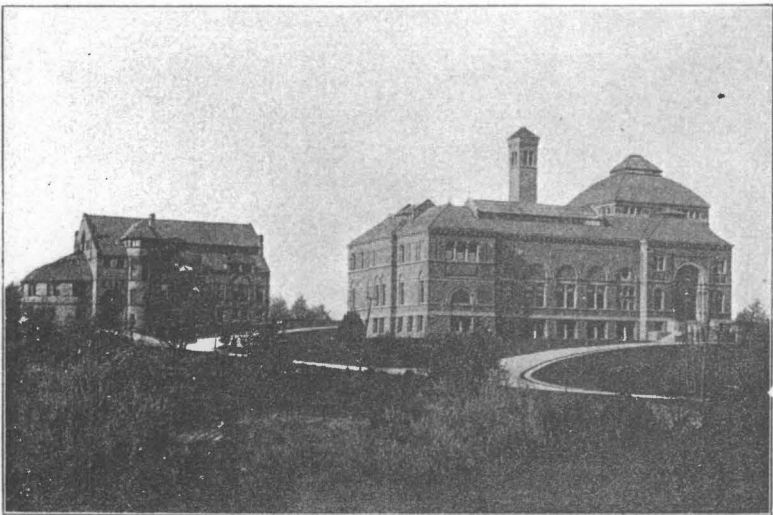

B.—Art Museum (right) and Art School. Built in large part of Cincinnati limestone.

posures here are in boulder clay. The somewhat higher land (approaching 700 feet) north and west of the Zoo has a deeper covering of till than is common for that altitude, because of the tendency of the ice lobe from the north to climb the slope which lay directly in its way.

**Cumminsville Branch of Mill Creek Valley Lobe.**—At this place the lobe divided. A part of it passed west to Cumminsville and perhaps thence south, down what is now Mill Creek Valley. Its deposits, ice-laid and water-laid, built the extensive (though now much dissected) terrace which includes Spring Grove Cemetery and Parker Woods—the latter now a part of the Cincinnati park system. The level of this terrace is marked by that of Hamilton Avenue to beyond Spring Lawn Avenue, and various remnants of the same level may be seen across the valley to the west. Down this far the terrace is largely, though not wholly, of boulder clay. Farther south the only remnant is a shoulder or interruption, at the appropriate level, in the slope of the west bluff north of Fairmount. This is made by a cemented gravel, the counterpart of that which makes this terrace elsewhere, to be described below. It is only to be expected that, as the end of the ice lobe is approached, the times during which it covered the ground should become shorter and shorter, and the intervening times of absence longer and longer. The proportion of water-laid to ice-laid material should be correspondingly increased.

**Lobe in the Norwood Trough.**—The branch of the Mill Creek Valley lobe which turned to the east was guided by the Norwood trough, the old valley in which had flowed the former Ohio. This valley, with its former axis not more than 360 feet above the sea, was filled partly, as described on page 121, and the rest with glacial deposits and outwash in the same manner as Mill Creek Valley described above. The level of its axis was raised to nearly 600 feet. As far down as this filling is exposed it consists of the same materials as those named in the sections near Carthage and Hartwell. Where the Norfolk & Western Railway crosses the Duck Creek road, till is exposed to a depth of fifty feet. A short distance to the northeast is a similar exposure, but here the till is interbedded with water-laid materials. Duck Creek, a small stream developed at a later time, has cut down into the new surface of the valley, exposing the materials to a depth of twenty to forty feet. Till is the chief substance seen in most of these exposures.

By far the best exposure of the deposits which fill the Norwood trough is seen at the east end where this trough borders the Little Miami Valley along the line of the Norfolk & Western and the Pennsylvania railroads. Along this line for a distance of about two miles. the Norwood trough ends in an escarpment which at its east end is more than 100 feet high, overlooking the flood plain of the Little Miami. This escarpment is primarily the bluff of the Little Miami and due to lateral corrasion by the stream, but it has been freshened and steepened

by excavation for the railroads whose tracks are twenty feet or more above the stream. A section of about eighty-five feet above the railroad, and near the east end, shows the beds in the following order named from the top downward:

*Section One-half Mile East of Batavia Junction*

	Feet.
(1) Loam and soil .....	10
(2) Bluish-gray till, somewhat oxidized .....	5
(3) Coarse to fine sand with thin plates cemented by calcite .....	15
(4) Covered (probably sand) .....	10
(5) Dark gummy clay .....	10
(6) Blue till, largely limestone, maximum size of stones 1 foot .....	15
(7) Yellow sand with thin clay streak in middle .....	15
(8) Blue gummy clay .....	3
(9) Talus .....	2
Total .....	85

Base at level of railroad a little less than 500 feet above sea level.

The thickness of the uppermost sheet of till, a short distance away, is much greater than it is here. It seems to be fairly continuous, forming the floor of the present Norwood trough. The lower sheet is exposed for about one mile, its average thickness being about the same as that shown in this section.

A number of deep wells have been drilled in this trough for the Norwood waterworks, the material passed through being recorded as gravel, sand, and clay, but it has never been observed with sufficient care to determine whether some of the beds thus described are boulder clay. It is highly probable that such is the case, and that the material for some distance below the level of 500 feet consists of alternating beds of the same nature as those here exposed.

The continuity of the beds in this exposure reinforces the impression made by the observations near Carthage and Hartwell, namely, that the ice alternately advanced and retreated considerable distances. It may be that the entire Mill Creek Valley and Norwood trough were several times covered by the ice, and completely laid bare in the intervals.

**Lobe in the Little Miami Valley.**—The Little Miami Valley, being narrower and less straight than that of Mill Creek, did not offer such favorable conditions for a persistent lobe of the glacier. The tendency is clearly shown, however, as seen in the deep deposits at Milford, Miamiville, and elsewhere. Where composed largely of till, these deposits are rather less uniform in altitude and less distinctly terrace-like in character than those in the valleys above described. This should be expected in a crooked valley where a glacial lobe tends repeatedly to push up one bluff or the other, and must constantly readjust its movements.

Since the Little Miami Valley is relatively narrow, and the stream much stronger than Mill Creek, the deposits of the Illinoian stage have been in large part carried away, but they remain in fragments as far north as Symmes Station. The bluff known as Cedar Bank, a mile east of Miami, is more than 100 feet high, its upper half being of till. The covering of talus and forest below may likewise conceal till. In the almost inaccessible upper half there seems to be some evidence of water work in several horizontal streaks of silt.

The high hill in the town of Milford is of the same nature, and shows that deposits of this epoch once filled the valley from bluff to bluff. The material of this hill is not well exposed, but a mile to the north, likewise in the middle of the valley, are two smaller hills rising to about the same altitude (about 650 feet). These are likewise remnants of the same deposits, and one of them, nearest the railroad, has been partly cut away, exposing a good section. The material there exposed is as follows:

*Section in Hillside One Mile North of Milford*

	Feet.
(1) Surface clay or loam.....	3
(2) Gravel largely of limestone pebbles, some of them striated, probably a very gravelly till.....	10
(3) Chiefly sand, much cross-bedded, locally cemented to a sandstone..	11
(4) Very gravelly till, with large boulders and striated pebbles, locally cemented.....	4
(5) Sand and gravel.....	8
(6) Yellow till; a band of very uniform thickness.....	1½
(7) Bluish-gray till.....	18
Total.....	55½

Base of section at level of railroad; altitude 580 feet.

A short distance away, excavation has shown that the till at the base goes at least ten feet deeper.

Four miles southeast of Milford, against the north bluff of the East Fork, is a terrace, which, according to the U. S. topographic map, rises above the level of 660 feet. It is composed of limestone gravel, which at the outcrop is firmly cemented. It may be that its sub-structure is in part composed of till. It indicates that the valley of the East Fork, at least near its mouth, was filled to the same depth as that of the valley at Milford. Probably the ice lobe divided at the bluff behind South Milford, one part going a short distance up the valley of East Fork.

The main ice lobe continued down the Little Miami Valley and joined that which came through the Norwood trough. The united stream of ice (and the waters which issued from it) aggraded this portion of the valley to about the same level as the Norwood trough. The proportion of water-laid to ice-laid material increases to the south. In

the east bluff of the Little Miami, near where the traction lines to California and Mount Washington cross the stream, is a good exposure of sand and silt, some of it minutely laminated. This is overlain by at least fifteen feet of till, representing a deposit which was no doubt thicker before erosion. This till now caps the ridges and remnants of a very much eroded terrace, similar to those farther north, but rising little above 600 feet. Other sheets of till may perhaps be interbedded with the sand and silt below the level of the exposure.

**Lobe in the Ohio Valley.**—The same glacial lobe continued south beyond Coney Island, making a large deposit of till at California, which caps a terrace three-fourths of a mile wide. This is the terrace in which the upper settling basins of the Cincinnati waterworks are dug. This sheet of till is locally at least twenty feet thick. It may be thicker, and there may be deeper beds of till not exposed, but the most southerly point at which two distinct and well separated beds of till are exposed is the bluff at Batavia Junction, south of Madisonville, described above. It may be that the ice tongue pushed forward but once to California, and that this event came late in the Illinoian stage when the great valleys had already been filled to an altitude of approximately 600 feet with outwashed sand, gravel, and silt.

Going southeast from California, that is, up the Ohio, the last good exposure showing both till and gravel in the same section is on the road from Coney Island to Mount Washington, about one-half mile from the former. Here, in a gravel pit beside the road, twenty feet of till rest on forty feet of gravel and conglomerate. The till contains abrupt pockets of gravel, indicating the abundance of water beneath the rapidly wasting ice. The gravel consists mainly of limestone pebbles, the largest being three or four inches in size. (See Pl. VI-A.)

Eastward, beyond this road, the terrace diminishes in width and clearness to Fivemile Creek, beyond which it is not recognized. It is composed largely of cemented gravel (Pleistocene conglomerate). Outcrops of such beds appear in the terrace edge at California. They are very conspicuous at Coney Island and at various points to the east.

The reasons for referring the till of this California terrace to a lobe of ice following the direction of the valley, rather than to the widespread sheet which is known to have reached the Ohio, and locally to have crossed it, are as follows:

(1) The adjacent bluffs are essentially without drift, and the uplands have very little. (2) The deep till is in terrace form, neatly limited to a certain altitude. This abutting of a horizontal surface against the steep bluff is a feature of the drift only, and does not belong to the underlying rock. (3) There are no similar thick deposits of boulder clay in the Ohio trough farther southeast, or even in the Cin-

cinnati basin, which was crossed by the ice sheet, but not favorably situated to be reached by valley lobes. (4) This interpretation is consistent with the evident history farther north.

In speaking of a glacial lobe occupying Mill Creek Valley, and advancing south through the Norwood trough and Little Miami Valley and up the Ohio, it is not intended to imply that a lobe extended this entire distance after the adjacent uplands were everywhere free from ice. How far the lobe at any one time extended forward from the main ice sheet is not determined. The significant points are that the main ice movements followed the great valleys, and that glaciation affected them in a manner quite distinct from the way in which the uplands were affected, and to a very much greater degree.

**Behavior of the Ice in the Miami Valley.**—The trough of the Miami below Lindenwald was less favorably situated to develop an independent glacial lobe, since the section between Hamilton and Harrison lies almost transverse to the direction of glacial movement. There is much till in the New Haven trough, but most of that which appears at the surface was deposited in the later glacial stage. The extent to which this part of the valley was filled by Illinoian drift has not been determined.

#### THE SANGAMON INTERGLACIAL STAGE

Following each stage of glaciation there was one in which the climate was not very different from that of the present time. Such stages are called interglacial. Should glacial conditions return again, the epoch in which we live would, of course, be interglacial. If we assume the current century to be in the middle of this stage, ours would be a very short interglacial stage as compared with some of the others, probably the shortest of all.

The time of deglaciation which followed the Illinoian glacial stage is called the Sangamon interglacial stage. The name is taken from Sangamon County, Ill. (containing Springfield), where the evidences of this stage are clearly shown, and have been well studied.

**Topography Left by the Illinoian Glacier.**—When the ice of the Illinoian stage finally disappeared from southwestern Ohio, a topography appeared which was not very different from that of the present. The drainage was along present lines, though the narrows, marking the places where great streams had found new courses, were even narrower than at present. The great valleys were the same then as now, except that the axes of some were from 100 to 200 feet higher than now; that is, the deep valley filling, now represented only by terrace remnants, was then continuous, and the streams ran over its surface at the level of the present terrace tops. The small valleys which open into the large ones were, of course, correspondingly less deep in their

lower courses. The axes of most small valleys were less sharply entrenched than now, and most of these streams were shorter at their heads, and had fewer tributaries than at present. Some other details were different because the covering of surface silt to be described below had not yet been spread.

The above description applies primarily to Hamilton County. In Butler County, or speaking more strictly, in the area covered by the later drift sheet, the difference between the present topography and that at the close of the Illinoian stage would be of the same general character; perhaps less than in Hamilton County.

**Erosion and Soil Making.**—On the surface of the newly made Illinoian drift sheet, the great streams began at once to entrench themselves by cleaning out the drift from their valleys. The smaller streams began at the same time to deepen their narrow valleys and elongate their heads, and send out more tributaries. The chemical and organic agencies described in Chapter IV began to change the character of the till and make a soil. Before the old soil made in this interglacial stage was covered up, it became considerably deeper than the one which was formed on the newer drift since the last glacial stage. This is one of the evidences from which it is inferred that the interglacial stage was much longer than the postglacial.

**Relative Amounts of Erosion on the Older and Newer Drifts.**—Another kind of evidence bearing on the length of time which has elapsed since each glacial stage, is the amount of erosion on the drift of different ages, where it has remained uncovered by later drift. On the uplands and in the bluffs, the size of a valley indicates little or nothing as to the amount of erosion since the ice departed. This is because the streams are running so largely in valleys cut before the glacial epoch. In the great valleys, however, the erosion which followed the Illinoian stage started on the nearly flat surface of the deposits described above. The valleys in these deposits, therefore, represent the postglacial work of the streams which now occupy them. Illustrations of this erosion are so widespread as to make mention of them almost unnecessary. The immediate valley of Duck Creek, in the Norwood trough, is wholly postglacial, and almost everywhere in its vicinity its larger tributaries have cut out valleys twenty to thirty feet deep, and having flat bottoms from fifty to several hundred feet wide. The valley of Ludlow Run, followed by the Southern Ohio traction line west of Spring Grove Cemetery, and heading at College Hill only two miles away, is seventy-five to one hundred feet deep and forty rods wide, cut wholly since the Illinoian glacier departed. Many streams not more than two or three miles long in the deposits of this age have valleys cut to their local base levels, and have already developed flat bottoms several hundred feet wide.

If these valleys be compared as to size with those of similar streams

on the newer drift sheet to the north, choosing places where the latter is also flat, it will be seen that the valleys in the older drift are many times as large; ten to twenty times would not be an unreasonable estimate. It thus becomes apparent that the interglacial stages, even though they do not attract attention by any deposits made at the time, are very important in the history of the present surface.

### THE LOESS STAGE

There is one important deposit in this region which appears to have been made at a time distinctly later than the Illinoian glacial stage, and distinctly earlier than the last or Wisconsin glacial stage. In other words, the time of its making seems to be separated from the Illinoian by a distinct stage, the Sangamon, and from the Wisconsin by an equally distinct stage. This deposit is *loess* or windblown dust, accumulated locally in this area to a thickness of twenty or thirty feet. Farther west, in the upper Mississippi Valley, it is even thicker.

#### *The Typical Loess*

**Character.**—This dust deposit appears now as a mealy earth, generally of light yellow color. When dug out of a bank in a fairly dry condition it breaks into fragments. Such a fragment, when crushed in the hand may offer considerable resistance, but gives way all at once, and crushes into a meal too fine to be properly called sand, but too coarse to be called clay. It does not form crumbs, balls, or lumps as clay does. Careful search will often disclose within it small coiled shells belonging to species still living. Not infrequently there are also calcareous concretions from a fraction of an inch up to several inches in the longest dimensions. These may have odd forms, suggesting the German word *Loess Kinder* (loess children). Within this area such concretions are rare.

When examined under the microscope this loess is seen to be made up of small angular fragments of quartz and other minerals from the igneous rocks which make up the glacial drift from the north. Such an examination has not been made for this area, but the material here is evidently identical with that farther west. Professor Salisbury found the loess at Kansas City to consist of particles ranging in size up to one-tenth of a millimeter (one two-hundred-fiftieth of an inch). But this size is extreme; only 4 per cent of the particles measured more than one ten-thousandth of an inch in their greatest dimensions; but this is still much larger than the average of clay particles.

Near the base of the loess, where it rests on the boulder clay, or even on bed rock, may often be found a few pebbles of the kind which occur in the till. Its exact base may thus be hard to determine. The



upper two or three feet may also be difficult to recognize as loess, because the decomposition of the constituent mineral grains yields so much true clay that the substance becomes stiff and may form clods.

A striking characteristic of loess is its tendency to "pack" into a mass which has a certain amount of rigidity. This is an essential property of molders' sand, for which loess is much used. It depends in part on the presence of angular grains of all sizes. Along with this goes a tendency to split in vertical planes or joints. These joints subdivide the mass into vertical prisms, not noticeable except on the weathered face of a loess cliff or bank. Partly on account of this packing and vertical jointing the loess has the peculiar property of standing in vertical faces. In excavations such vertical faces often endure for many years despite the mealiness of the material when crushed. This is only true where the surface drainage goes the other way and does not pass over the face of the exposure.

**Distribution in the United States.**—The formation here described is most abundantly represented in the states bordering the Missouri south of the Dakotas, and the Mississippi south of Minnesota. South of Illinois it appears chiefly in a belt bordering the Mississippi on the east. In these southern states it is generally known as the "brown loam," especially at some distance from the river, where its color is generally darker and its constitution more clayey. It is also spoken of as "bluff loam," especially near the river, and sometimes merely as "bluff."

Speaking of the entire area in which the true loess occurs, it is most prominent near the larger streams, especially those flowing south. In a very general way, also, its thickness decreases toward the south. It is generally much thicker on the east bluff than on the west, and on both sides it diminishes in thickness and becomes more clayey as the distance from the stream increases. It is also a very significant fact that it is generally (though not universally) absent from the surface of drift sheets which are younger than the Illinoian.

**Distribution in This Area.**—In the area under consideration the true loess is found only in small spots, a very few square miles, in the immediate vicinity of the Ohio. The bluffs on the Kentucky side from Bellevue to Ludlow are well covered, except on steep slopes from which it may have been eroded. Probably the maximum thickness, at least thirty feet, is found in the Covington City Park, on the high ground southeast of Ludlow and south of West Covington. Probably the largest deposit on the Ohio side is at the foot of the bluff on the road leading northeast from Delhi.

**Origin of the Loess.**—The origin and mode of accumulation of the loess may be inferred from its constitution and distribution. The fact that its grains consist in large part of minerals which make up the glacial drift, and the further fact that some of these particles are still

fresh, indicate that it was reduced to its present fineness by mechanical means rather than by decomposition. Its relation to the glacial drift suggests that this comminution might have been in large part mere grinding beneath the ice, and, therefore, that the loess is derived from glacial drift by some process of assortment. Its association with the great streams indicates that they were the primary agents of its distribution, and probably also of its assortment from the body of the till. Its presence on hills and bluffs, regardless of height, leaves no doubt that it was transported by wind as well as water, while the greater thickness on east bluffs points to the prevalence of westerly winds, and suggests that the flood plains of these streams were the source from which the wind gathered the material.

Following the inferences thus drawn, a picture of conditions during the loess-making time may be reconstructed as follows:<sup>1</sup>

The streams which flowed south from the source of supply were heavily charged with silt. It might be assumed from this fact that the streams were aggrading their channels, filling their valleys; and this was probably the case. In doing this they not only made wide flood plains but were subject to great floods. In times of flood the silt spread out on the flood plains, and in times of drought it was picked up and carried by the winds over the uplands. The sand was drifted to and fro on the flood plain, sometimes building dunes, as in a later time at Ludlow, Ky. (see p. 161.) These would be quickly carried away when the streams began again to degrade their valleys. Perhaps none remain from the loess stage. The silt would be carried higher and farther, settling in greatest abundance near to the source of supply, that is, on the bluffs. The deposit should be thickest on the bluffs, not only because they are near the source of supply but because the coarser grains settle first, and that which is regarded as typical loess is of relatively coarse grain when compared with other atmospheric dust. A similar process of wind deposition is now going on at the same place, but the amount of dust now carried is too small to accumulate as a distinctive deposit. It is not improbable that more is being removed by wind from the bluffs than is being added. Small mollusks, which lived on the land and in pools, were often covered by the drifting dust, and their shells were thus fossilized in the loess.

The location of the true loess in this area is in general consistent with the above view of its origin. This is especially true of the bluffs behind Newport and Bellevue. They lie on the leeward side of a broad alluvial flat (the Cincinnati basin). It is true that a prevailing northwest wind would be better suited to this hypothesis than the prevailing southwest wind now observed. The same is true at Delhi, where the valley to the northwest offers a free sweep for the wind. The

---

<sup>1</sup>See Chamberlin, T. C., Supplementary Hypotheses respecting the origin of the loess of the Mississippi Valley. *Journal of Geology*, Vol. 5, pp. 795-802, 1897.

locality of thickest deposit west of Covington does not lie in the lee of the broadest flats when the winds are westerly, but on the other hand it has flats on three sides, from all of which it might have received accretions.

### *The Surface Silt Elsewhere*

**Relation to the Loess and Drift.**—Over most of Illinois and southern Indiana, except near the Mississippi, Illinois, Wabash, and other large streams, the Illinoian drift sheet and the adjacent driftless region is covered with a sheet of loam or silt, which has some features in common with the loess. It is finer in grain and of more clayey appearance, and is generally less than ten feet thick, frequently only two or three feet, and entirely absent from many steep slopes. It resembles the loess in covering hill and valley alike, regardless of altitude. Like the true loess also, it is apparently independent of the material which it covers. Not only does it seem improbable that it should be formed by the weathering of the material beneath, but there is much evidence that the drift sheet was old and deeply weathered before this surface covering was added. Moreover, it extends without abrupt change of character beyond the limits of the drift into the driftless region on the south.<sup>1</sup>

This sheet, often called the "white clay," extends east over the area here described, probably as far as Parkersburg, W. Va. It is limited on the north by the edge of the newer drift.

So far as can be detected, this surficial sheet of silt is continuous with the true loess. The coarser grain and greater thickness of the latter seems to give way gradually to the more clayey character and diminished thickness of the former. In this locality the thickness of the surface silt is rarely less than two feet, except on steep slopes from which it may have been eroded. Locally the thickness is four or five feet.

**The Phase Called "White Clay."**—Generally this surface silt weathers into a rather mealy soil of light color. It is especially light in color on flat uplands, which are poorly drained. From such areas, which are abundant in parts of Illinois, southern Indiana, and even southern Ohio east of this area, the formation has taken its popular name "white clay." Such spots are not abundant in the area here treated, but their character is well exemplified in the flat lands about

<sup>1</sup>While the character of this sheet of clay or silt is well exemplified in this area, its relation to the underlying till is not so clear. Such statements as the one made above regarding an earlier soil formed on the till, rest largely on the field work of Mr. Frank Leverett of the U. S. Geol. Survey, who has studied the glacial formation very widely. There are, however, some very good exposures close to Cincinnati which suggest the relation here described. As it is not the purpose of this bulletin to discuss unsettled questions, and as Mr. Leverett has probably worked and written more extensively on the Illinoian drift than any one else, the interpretations here presented are essentially those which he has given.

Bevis, three miles west of New Burlington, and likewise on the flat upland strip followed by the Cincinnati, Lebanon & Northern Railway, from Deer Park and Rossmoyne north to the edge of the newer drift near the Hamilton-Butler County line. The flat fields including the brickyards south of Brecon are good examples. Similar illustrations are found on some of the flat uplands of Boone County, Ky.

Beneath the top soil it is more yellow and, where poorly drained, is often bluish at the base. At places, scattered throughout the entire thickness, but more abundant near the base, are small pebbles of chert, quartz, quartzite, and igneous rock, all representing the more resistant materials of the drift.

Analyzed both chemically and physically this formation is shown to consist of particles very similar to those which form the loess, though smaller. There are also many small concretions of limonite, the common oxide of iron which constitutes rust.

**Other Phases of the Surface Silt.**—With better drainage this surficial formation assumes darker colors, the surface soil formed from it being light yellow rather than pale gray, and the subsoil more ruddy. At depths of two or three feet the material is often brown, traversed by blue cracks, or mottled with blue and carrying concretions of limonite. Either at this depth or lower are generally found the chert and other pebbles mentioned above. Either at the horizon of these pebbles or below it is found, at many places, a stiff brown gummy clay, of the kind which may be formed by the decomposition of our local bed rocks or of the till.

Generally speaking, the body of this formation below its weathered surface is silty rather than clayey, and yellow rather than white or even gray. For the purpose here in hand, therefore, it is commonly referred to as the surface silt, a merely descriptive and not a technical term.

**Origin of the Surface Silt.**—If this surface sheet of silt is a direct continuation of the loess, and grades into it, then it was presumably deposited by wind, as was the loess. Its finer grain and texture are accounted for by the fact that wind, like water, when depositing its load, drops the larger pieces near to the place where the load was picked up. This would leave only the finest dust to be deposited at a great distance from the major streams, whose flood plains furnished the material of the loess. The same principle would account for the relative thinness of the deposit.

The chief difficulty in assuming such an origin for this formation lies in the presence of the pebbles. It has been suggested by Leverett<sup>1</sup> that some of these were brought up from the underlying till by crayfish

<sup>1</sup>Glaciation in the Erie and Ohio Basins, U. S. Geol. Survey Monograph No. 41 p. 298.

or other animals during the gradual accumulation of the deposit, just as the same animals working in the same material occasionally bring up small pebbles now. The fact that these stones consist exclusively of chert, quartz, quartzite, and other rocks which are very enduring, is assumed by him to indicate that all limestones had already dissolved out of the soil before this formation was deposited.

Instead of assuming that the material of this entire formation was imported from the same localities that furnished the loess, and, therefore, from a long distance, it is possible to conceive of the greater part of an aeolian deposit as being laid down not far from the place where the material was picked up. According to this supposition the loess is coarser than the widespread silt, not so much because it represents the material first dropped, as because the locality from which it was derived afforded a supply of coarser material. The broad flood plains, of course, afforded sand and particles of all sizes smaller than sand grains, but the sand generally fell again on the flood plain and would be again quickly carried away by the water.

If the surface silt be a wind deposit, it, like the loess, indicates an arid climate at the time of its making, or at least a time of extreme intermittent droughts. In such times dust is not brought to a place and deposited once for all, but is blown here and there many times, or many hundreds of times, before it is effectually buried and kept in place, or the aridity ceases. If a very limited surface like that of a county start in such an epoch with no wind deposit whatever, and none is brought in, it will nevertheless gradually acquire such a sheet, derived from its own soil. One spot will furnish dust which will settle at another. On another day the deposit will be shifted and new dust added to it from the exposed ground. The sites of erosion and deposition shift from day to day, or from storm to storm, but bare spots subject to fresh erosion become smaller and fewer as the amount of drifting material becomes greater.

It should not be assumed that the material thus subject to wind action was all laid down locally, or derived from nearby. There have probably always been "prevailing winds" from some direction, which would result in an aggregate movement of dust in some one direction. Moreover, the uniformity in thickness of the surface silt does not permit this conception of to and fro shifting to be adhered to exclusively. It is probable, however, that a large part of the area furnished dust as well as received it.<sup>1</sup>

---

<sup>1</sup>Since this was written a study of similar deposits in Iowa has caused certain careful observers to entertain the hypothesis that they are residual soil derived from decay of the drift beneath. This hypothesis and the suggestion here made of local to and fro shifting do not exclude each other. Even if all the factors mentioned should prove to be involved, further investigation is necessary to determine their relative importance.

## THE POST-LOESSIAN STAGE

Over somewhat more than the southern half of this area, the surface silt was the last formation deposited on the uplands. When it ceased to form, the present cycle of erosion began. In the northern part of the area the later glaciation interrupted this cycle, or brought it to a close. The time between the deposition of the surface silt and the newer glaciation constitutes a distinct stage. The same changes which are now at work at the surface were proceeding in that stage, namely, rock decay, soil-forming, and erosion. At a few places we have records of how far these processes went before the Wisconsin glacial stage, and therein we have some evidence of the length of this stage. Thus, on Twomile Creek in Hamilton (see section, p. 147, also Pl. VI-B), six feet of this old silt are seen in the bank between the older till below and the younger till above. The silt is much weathered, and for the most part converted into a soil. If this weathering was all done before it was covered up by the twenty-five feet of younger till, the time during which it was exposed must have been very long, much longer in fact than that which has elapsed since the last ice withdrew. A similar section bearing the same evidence is found in a high creek bank two miles northeast of Glendale.

## THE WISCONSIN GLACIAL STAGE

*Work of the Ice*

**Early and Late Wisconsin.**—The last stage of glacial conditions in this area, and the last in the United States, is called the Wisconsin. If the area here described extended ten miles farther north it would be necessary to subdivide this stage into early and late Wisconsin, for the stage represents two distinct advances of the ice, the latter falling short of the former by about twenty-five miles in this region. Only the early Wisconsin glacier invaded this area. These advances were not separated by a very long time, but each has its own deposits, which at many places are distinguishable.

**Limits of Advance.**—The limits to which the glacier of this stage advanced are best seen on the accompanying map (in pocket). Briefly summarized, it crossed the New Haven trough to the bluffs on the south, but at the western edge of the area it did not reach so far south, the local trend of the ice front being from northwest to southeast. Above New Baltimore the present channel of the Miami was buried, but below that point it remained free from ice. Between New Baltimore and Banklick Creek (distinguish from Banklick Creek, Ky.) the ice was checked at the foot of the bluff or part way up on the slope. East of that creek the glacier scaled the bluff and spread south over the upland,



but it was still unable to override the highest points. The effects of the 920-foot knob in section eight (Ross Township, Butler County, see topographic map) is particularly noticeable in causing a re-entrant curve in the ice front. From here the line trends southeast until within a mile or more of Mill Creek Valley. Here the effect of that large valley in developing an ice lobe is distinctly seen. This lobe advanced southward to Hartwell, its western edge for four miles being almost parallel to the valley. Turning north again at Hartwell, the eastern edge of this lobe follows the bluff almost to Sharonville, a distance of more than four miles, in a direct line. North of that the ice sheet covered the upland on the east, its edge trending northeast to near Foster. It does not appear to have crossed the Little Miami within the limits of this area.

In a general way the front of the ice seems to have trended both northwest and northeast from this area. The great southward advance within this area is therefore very marked. This is probably due mainly to the influence of the broad Miami Valley south of Dayton.

**Thickness of the Drift.**—The deposit of till made by the Wisconsin ice is on the whole thicker than that made by the Illinoian. Probably the combined thickness of the older and younger tills would average fifteen to twenty feet. Most of this is the newer deposit. The older was always thin, and in addition was doubtless, to some extent, disrupted by the advancing ice, and incorporated into the new drift. The aggregate thickness of the two on relatively plain ground may occasionally reach thirty feet, but greater thicknesses are for the most part confined to old valleys.

Not only is the general thickness of the later till greater than that of the earlier, but there is in some places a distinct thickening as the edge is approached. Many wells in the vicinity of Mason are reported to show a thickness of approximately forty feet of till, and in isolated cases not far away, much greater depths are reported. Near Pleasant Run, on the C. D. & T. Traction Line, similar depths are reported.

**Topography.**—The thicker drift here described does not constitute a good terminal moraine, but there are, near the border, spots of considerable size which have a morainic topography, that is, they are characterized by hummocks, and in a few instances by undrained hollows. One such spot is found on the western border of the area from one to two miles north of Shaker Village. North of New Baltimore is a similar topography. A considerable area near the Hamilton-Butler County line, west of the C. D. & T. Traction Line, is distinctly morainic; likewise a few small patches northeast of Sharonville.

As already described, the topography of the Wisconsin drift sheet is due in the main to pre-glacial erosion, the valleys now being at the same places as they were before the advent of the ice. The newer



drift sheet has this in common with the older. On the older drift there has, however, been much erosion since the ice disappeared; on the newer drift, there has been very little. Post-glacial streamlets have searched out the lowest line on which to run, and there may be something of a channel along such a line, but along most of the subordinate drainage lines there are, properly speaking, no stream valleys. Only streams of some size and permanence have erosion valleys cut beneath the levels which they found, and bounded by slopes of their own making, either ravine slopes or bluffs.

**Character of the Till.**—The drift of this stage is not sharply distinguished in character from that of the earlier. It has in general a lighter color and is softer and easier to dig, partly, no doubt, because it contains more sand, both mixed with the clay and localized in pockets. It is probably stonier also, and the percentage of igneous and metamorphic rock to limestone is greater than in the older drift; it may be as much as four or five per cent. The joints described in the Illinoian drift (p. 125) are less prominent in the Wisconsin, though by no means wanting.

The till of this age is calcareous like that of the Illinoian, and it has been less deeply leached in the formation of soil. The yellow zone due to surface oxidation is also less deep, but the contrast between young and old drift in this respect is not so great as might be expected, probably because the more porous character of the younger till has permitted the agencies of chemical weathering to work more rapidly.

The Wisconsin till is not covered by the surface silt described as covering the Illinoian, but its surface portion, from one to three feet deep, is in many places almost free from stones. In places this want of stones, at and near the surface, is very striking. Along the road eastward from Hamilton, past the infirmary, a trench two to two and one-half feet deep was dug for a pipe line. In two miles east from the infirmary scarcely a stone was thrown out. Generally the number of stones increases gradually with depth, but at places there is a sharp line separating the stoneless clay above from the stony clay below. Where this is the case it seems to represent a mode of deposit not described above. Glaciers may carry on their surfaces considerable layers of sediment. Such deposits on continental glaciers must necessarily be local and near the edge (see p. 106). When they consist of silt, it may have been brought partly or wholly by wind from the land surface in front. In the final melting of the ice, such "super-glacial drift" is quietly let down on the till below. It is doubtful if this process in detail can be invoked to account for all of the stoneless clay found in this area. Such clay is, however, sufficiently abundant here and elsewhere to call attention to the fact that the deposit of the topmost foot or few feet of glacial material is often to be explained by a different process from that which explains the lower deposit.

**Contact of the Two Drift Sheets.**—The distinction between Wis-

consin and Illinoian till, when exposed in the same section, is not always easy. In some exposures, believed to show till of both ages, the oxidized joints described above cross the boundary and extend many feet up into the younger formation. In at least one bank, two miles west of Glendale, water issues at the base of the softer till, evidently because it fails to percolate into the denser formation below. Many ravines cutting deep into the younger till expose below, a bowlder clay which has all the features of the typical Illinoian; yet the silt which commonly covers the latter is wanting and there is no suggestion whatever of a surface of contact. While some of these exposures are doubtless of Wisconsin till from top to bottom, it is likely that the base of some of these sections is of Illinoian age. The want of any evidence of contact may be due to the disrupting of the surface of the older formation as the younger glacier advanced, and the incorporation of some of the older material in the newer formation. The same process would obviate any sharp contrast in physical character. It is not to be expected that the two formations can always be distinguished even where found together. Much less is it possible to judge of every exposure at sight, whether it be one or the other.

The best section showing the deposits of the several glacial stages is found in the north bank of Twomile Creek in the city of Hamilton, about forty rods west of the C. D. & T. Traction Line. It is as follows:

*Section on Twomile Creek, Hamilton, Ohio*

	Feet.
(1) Clay soil and subsoil with few stones .....	1½
(2) Oxidized till of pale yellow color, grading into bluish till below....	7
(3) Bluish till containing lenses of silt and gravel .....	16
(4) Silt oxidized to a purplish brown, containing pebble of chert and igneous rock near the base.....	6
(5) Hard yellow till, grading into blue below.....	7
(6) Very hard blue till, base not exposed .....	14
<b>Total</b> .....	<b>51½</b>

In this section, number six is typical Illinoian till. One hundred feet away the oxidized fissures are strikingly exemplified. Number five is the oxidized phase, the topmost one or two feet being leached of its lime. Number four is plainly the surficial silt with its highly characteristic pebbles near the base. The whole thickness is here well oxidized, in part, no doubt, by weathering and soil-making before the deposition of the overlying till; in part, also, by ground waters which later followed this porous bed between the two tills. The dark color becomes more prominent near its base and extends over a little into the underlying till. Numbers three and two (Wisconsin till) do not differ greatly from the corresponding phases in the Illinoian till

as seen at many places. As compared with the Illinoian till in this section, they are slightly less hard and paler in color. The lower till also lacks the silt and gravel lenses.

**Behavior of the Ice.**—From the description here given of the later drift sheet the behavior of the glacier may be inferred. The greater thickness of the drift, especially near the edge, indicates that, as compared with the older ice sheet, the Wisconsin glacier kept up its power better as it approached its limit. Probably it moved faster, and thus carried a greater thickness of ice close to the limit.

#### *Work of Water in the Wisconsin Stage*

**Evidences of Abundant Water.**—Water flowing out from the edge of the Wisconsin glacier, and due largely to its melting, seems to have been more abundant than that which flowed from the former ice sheet. This tends to confirm the inference already drawn from the deposits of till, namely, that the thickness of the later ice sheet was better maintained as its limit was approached. The evidences of this abundant water are found partly in the main drift sheet itself, which contains pockets of stratified, that is, waterlaid sand and gravel. It is seen more clearly in the kames built at the edge of the ice, and still more clearly in the great valley trains, fragments of which constitute the sand and gravel terraces in the great valleys. (See map, in pocket.)

**Outwash Deposits of Different Ages.**—The deposition of valley trains by outwash from the glacier has been described on page 110. Those in this area were deposited in part when the ice front stood at its extreme limit, shown on the accompanying map; but their accumulation began as soon as the advancing ice invaded the upper basin of the Miami, and continued during its retreat to the same place. Necessarily, those parts which lie north of the limit of the Wisconsin ice sheet were deposited during advance and retreat only.

As stated above, the Wisconsin glacial stage was double, the ice coming down a second time to a line about half way between Dayton and Hamilton. A portion, perhaps a large portion, of this outwashed sand and gravel was due to this later advance, which did not otherwise affect the area here described. It is not possible at present to distinguish the late Wisconsin outwash from the earlier.

Probably when this outwashed material began to be laid down, there remained, at least locally, in the bottoms of the great south-leading valleys, some of the till and some of the outwashed sand, gravel, and clay from the Illinoian stage. (See Fig. 50, p. 128.) Of the several hundred feet of sand, gravel, and clay passed through at Hamilton before reaching the rock, it is not possible to say how much remains over from the older glacial stage and how much was deposited in the newer. This is equiva-

lent to saying that it is not now known how deep the inter-glacial streams in these valleys had cut their channels before the approach of the newer ice sheet caused them again to aggrade.

The "Forest Beds."—There is one feature in the banks of the Ohio which has sometimes been interpreted as giving the answer to this question. This is an occasional exposure of muck or dark mucky clay, seen only in spots and at favorable times after scouring has been effected by floods. Here and there it may contain wood, leaves, etc. It suggests driftwood buried beneath the flood plain deposits of a shifting stream. As such, it might have been laid down at any time, however recent, as similar deposits are being made and covered up now. The exposures of this deposit have, however, all been about ten feet, or a little more, above low water, which suggests that they were all made at the same time on the surface of an ancient and now buried flood plain. More convincing evidence was noted by Dr. Edward Orton at Lawrenceburg, Ind. There, at the corresponding level, was an exposure of several beds, called by him the "Forest beds."\* Here he found stumps in upright position as though still standing as they grew in the ancient soil. There were thin beds of ocherous clay both above and below the deposit containing the stumps. The overlying beds were reported by Dr. Orton to be not recent alluvium, but constituent beds of the great terraces. This deposit he interpreted as marking the surface of the flood plain at the close of the inter-glacial stage, when the outwash began to deposit in advance of the oncoming Wisconsin ice sheet. In the Miami Valley, below Hamilton, some drilled wells are cited by Leverett<sup>1</sup> as having passed through a bed of dark mucky substance about sixty feet below the surface. He suggests that this material may be muck accumulated on the Miami flood plain at the same time that the deposit was made at Lawrenceburg, and may thus mark the level of the inter-glacial valley floor near Hamilton. The differences in elevation between the beds at the two places correspond roughly with the fall of the river.

**Character of the Outwashed Material.**—While it is not possible to say of a well, at what depth the older deposit begins, and not always possible to distinguish the two deposits when seen in exposures, there are, nevertheless, certain characteristic differences. The newer gravel contains a larger proportion of stones from the far north. Not infrequently ten to fifteen per cent of the pebbles are of igneous rocks and quartzite. This is a much larger percentage than that found in the boulder clay. Such a contrast is to be expected, since the water-laid material represents the material dropped by the ice at a point farther north. The stones are usually well rounded, indicating much wear during their journey. It is not possible to make any general statement

\*Geology of Ohio, Vol. 1, p. 427, 1873.

<sup>1</sup>U. S. Geol. Survey, Monograph XLI, p. 318 and p. 322.

as to their size, because the material differs greatly in this respect in the different large valleys. It varies from the coarse material along the Little Miami at Loveland, where many stones exceed one foot in size, to almost pure sand, as found in parts of Mill Creek Valley. The newer outwash contains less clay than the older. Generally speaking, the sand of this age is sharper than that of the older formation.

Cementation into conglomerate is less frequent in the newer gravels, chiefly because there has been less time for the process. There are, however, conspicuous instances of such cementation, as in the banks of the Little Miami one-half mile north of Milford, and in Langdon's gravel pit at Linwood. (See Plate I-B.)

**Miami Valley Train.** — Remains of this valley train constitute a very broad terrace north of Hamilton. (See physiographic map.) Most of the "Hickory Flats" is of this origin. The altitude ranges from 620 feet to about 660 feet. The slope from the north bluff toward the axis of the valley is due to the fact that much of the material was brought in by tributaries from the north, and was deposited in excessive measure where the small valleys open into the larger. The material brought down by the Miami is sand and fine gravel, stones larger than two or three inches being exceptional.

Farther down the valley little is preserved of this formation until near the junction of the Miami and Whitewater. North of Miamitown at Valley View, a terrace of this age rises a little above 560 feet. This is in the narrower part of the Miami trough. It consists of coarse and fine gravel and sand, at places confusedly crossbedded. A large tract here is owned and reserved for gravel by the Chesapeake & Ohio Railroad. The Willey Construction Company also operates a large plant for the supply of commercial gravels a little farther north.

At Valley Junction, near the mouth of the Whitewater, the large gravel pits worked by the Big Four Railroad are in a terrace of this age rising 540 or more feet above the sea.

From the altitudes here given it appears that the down stream slope of the valley train was decidedly less than the present fall of the stream. The Miami falls from 625 feet at the northern edge of the area to about 440 at Valley Junction, a distance of thirty-five miles, measured along the axis of the valley, but ignoring the turns of the stream. In the same distance the altitude of the terraces falls from about 650 feet at Middletown to 540 feet at Valley Junction. The fall of the stream is 185 feet; that of the terrace level is 110 feet. This suggests two principles; first, large streams need less fall than small ones in order to carry their loads. The Miami no doubt carried more water then than now. Second, it was a depositing stream. The Miami is now essentially a graded stream, but is eroding rather than depositing. If its gradient were again reduced to what it was then, it would probably be unable to carry even its present load.

**Little Miami Valley Train.**—The corresponding terraces along the Little Miami begin at Loveland where the terrace rises above 600 feet. North of that the newly adopted valley is so narrow that the stream has succeeded in washing out whatever deposits may have been made. The stream here was necessarily swift, and the materials dropped were chiefly heavy stones. The gravel exposed at Loveland is made up largely of heavy fragments of limestone, some of them a foot in diameter. Descending the stream, the valley widens in irregular fashion, the terrace level falls, and the material becomes less coarse. It is present on one side of the river or the other for most of the distance to Terrace Park. (See map in pocket.) That village takes its name from a beautiful level terrace nearly a mile square, rising abruptly sixty feet above the flood plains, and abutting against the steep bluff on the west.

South of Terrace Park, remnants of the old valley train become more and more sparse to the mouth of the river, but fine remnants are seen both south and east of Newtown. The flat-topped ridge or hill stretching from Red Bank to Linwood is of the same origin. Here the material has a large proportion of sand, but through most of it is distributed gravel of medium coarseness. Cementation is locally complete.

The same relations as noted on the Miami between the gradient of the valley train and that of the present stream, are observed again here. The altitude of the terrace remnants falls from above 600 feet at Loveland to about 530 feet at Red Bank, a total fall of 70 feet. In the same distance the stream level falls from about 565 feet at Loveland to 455 opposite Red Bank, a fall of 110 feet. In other words, the terrace surface is 35 feet above the river at Loveland and it is 75 feet at Red Bank, indicating that the fall of the stream when the outwash was deposited was much less than its present fall.

**Mill Creek Valley Train.**—As Mill Creek Valley was the seat of the chief lobe of the Wisconsin ice sheet and the locality of its most southerly extension, it should also have furnished the chief channel of outwash. This does not seem to have been the case. As seen below, the Cincinnati basin appears to have been filled more largely from the east than from the north. Remnants of a valley train of Wisconsin age are not abundant south of Lockland. North of that there are few exposures, either natural or artificial, and it is not known how much of the "sand and gravel" mentioned in well sections is of this age and how much is older.

All of the gravel in this valley is relatively fine, and the terrace remnants are much more largely sand than gravel. One of these on the west side of Bond Hill has been excavated for sand to a depth of forty feet. A part of the sand is picturesquely crossbedded, indicating active local currents, but there is very little gravel. Its surface is flat and a little above 540 feet, this being the same level as the surface of the similar filling in the Cincinnati basin. It is a fair inference that

the entire valley north of this place was filled to this altitude or higher. Similar deposits in Reading are twenty feet higher. North of that the floor of the open valley, parts of which are on outwash of Wisconsin age, rises gradually to more than 600 feet near Lindenwald, where it falls off into the more recent trench of the Miami.

How far below Bond Hill the filling of Mill Creek Valley continued is not known. There are no remnants lower down in the valley which rise to the full height of 540 feet. Between Cumminsville and the mouth of Mill Creek there is evidence that stagnant water existed during the latter part of the time that these valley trains were being constructed, or very soon after. This evidence consists in fine laminated silt which is exposed near the stock yards to a thickness of more than twenty feet. Its surface is at least a few feet lower than that of the terraces at Bond Hill and in the Cincinnati basin, indicating that this stagnant basin was not completely filled with silt.

A suggestion as to the origin of this basin is that the mouth of Mill Creek was dammed by the valley train along the Ohio. If the 540 foot deposit which now partly fills the Cincinnati basin was extended across the mouth of Mill Creek, the possible fall in the total length of Mill Creek Valley was about sixty feet, that is, from 600 where it joins the Miami Valley to 540 where it joins the Ohio. The distance is about twenty-five miles, measured along the axis of the valley, without allowing for any meanders. This is less than two and one-half feet per mile, a fall sufficient for a large stream, but not sufficient to enable the smaller volume of water which traveled through the Mill Creek Valley to carry its load through to the Ohio.

At the north the Mill Creek Valley may be said to end at the 600 foot contour line, which runs nearly south from the bluff east of Hamilton and Lindenwald. The Miami Valley west of this line is from twenty to thirty feet lower than the Mill Creek Valley on the east. Locally the fall is abrupt, and the higher level on the east stands out as a distinct terrace. From this line eastward to Flockton the valley contains no stream. It is followed by the Miami and Erie Canal, whose constant level shows that the valley level falls slightly toward the east. The floor of this valley is in part flat and in part very faintly rolling. The latter parts are ice-laid drift, while the flat parts are sand, gravel, and clay, that is, water-laid.

The altitude of the sand and gravel floor of this valley is exactly the local level of the Miami Valley train. It appears that at some time after the glacier had receded northward beyond the junction of these two valleys, and the valley to the south had been much aggraded with outwash, the Miami divided at Lindenwald, one stream following its present course, the other following Mill Creek Valley. To what extent this occurred during the recession of the glacier which invaded this area, and to what extent during the life of the late Wisconsin glacier

which stopped farther north, is not clear. At all events the Miami during its aggrading stage was bifurcated at this point. The river at that time was not cutting a channel. It flowed, no doubt, in many small and shifting channels between shifting sand bars, as is the habit of overloaded streams. Its behavior could not have been very different from those parts of the present Platte River which are aptly described as "braided."

When the glacier disappeared and the overloading stopped, the stream began to cut a channel in its former deposits. The fork which followed the present course of the Miami then had the advantage of a shorter and more direct course, and hence larger fall than the fork which followed Mill Creek Valley. Hence the former was cut down more rapidly and took more and more of the water until the old course on the east was left dry.

The conditions thus depicted offer another suggestion for the deposit of silt in the valley of Mill Creek near its mouth. It will be remembered that this part of the valley failed to be filled with outwashed sand and gravel as was the valley north of St. Bernard. When the Miami no longer discharged a part of its water through the Mill Creek Valley, the unfilled lower course would be without current, and periodically filled by back water from floods in the Ohio. From such quiet flood waters, deposits of silt would be made very similar to those now found in this valley.

**Ohio Valley Train.**—Many terraces in the immediate valley or trench of the Ohio show that that valley was filled to an almost uniform height somewhat above 540 feet. From east to west across this area there is little or no fall in the height of these terraces. The map shows their locations at the mouth of Fourmile Creek, Ky., at California, in the Cincinnati basin, at Sedamsville, opposite Delhi, at Saylor Park (formerly Home City), and opposite North Bend. So far as observed, their materials are a medium grade of gravel with much sand.

By far the most important remnant of this valley train is the terrace on which the business portion of Cincinnati stands. Deep wells indicate that the maximum thickness of mantle rock is 185 feet, that is, from the surface at 545 feet to bed rock at 360 feet. Sand and gravel form the bulk of the material, with probably more sand than gravel. It appears that the upper thirty to sixty feet are generally free from clay, but that considerable clay is found at intermediate depths.

A study of the pebbles of this terrace was made by Orton<sup>1</sup> who classified them with reference to their derivation. His results were as follows:

---

<sup>1</sup>Geology of Ohio, Vol. 1, p. 432, 1873.



*Classification of Pebbles in the Cincinnati Terrace*

	Per Cent
Silurian and Devonian from the north.....	50
Ordovician (from nearby and part worn).....	30
Granitic.....	10
Sandstone, etc., from the Upper Ohio basin.....	10

The striking thing in this classification is the ten per cent of stone which could not have been derived from the basins of tributaries from the north, but must have come down the Ohio. This estimate is for the gravel exposed in the digging of cellars on the top of the terrace. The proportion of sandstones from the east may be still larger in the lower beds. Taking this fact in connection with the incomplete filling of Mill Creek Valley, it appears that the Cincinnati basin was filled chiefly by material which came down the Ohio and not down the Mill Creek Valley. However, the large proportion of stones from western Ohio indicates that the river derived its load largely from the Little Miami, Scioto, and other streams which enter the Ohio not far above Cincinnati. To what extent the valley train in the Cincinnati basin was completed at full height across the Mill Creek Valley is uncertain.

**Silt-Filled Valleys.**—The valley of the Licking, which heads to the south and flows north could, of course, not be filled with glacial outwash. It is observed, however, that the larger part of the valley of this stream (within this area) is floored by terraces whose level is essentially the same as that of the valley train. Covington stands on such a terrace and the entire Milldale (or Latonia) basin to the south has its floor at the same level. Many exposures show that these terraces on the Licking are composed of silt and not of sand and gravel like those on the other side of the Ohio. The explanation of this is that the detrital filling in the Ohio constituted a dam across the mouth of the Licking, thus ponding its waters. In the valley thus filled with standing water the mud brought down by the Licking itself was allowed to settle. Before the Ohio again entrenched itself, and thus removed the obstruction from the mouth of the Licking, the valley of the latter had been filled up almost or quite to the level of the ponded waters. To an undetermined extent, such filling was doubtless aided by back water from the Ohio during floods.

A small terrace in the valley of Fourmile Creek, where it leaves the Kentucky bluffs southeast of Fort Thomas, is of the same character. A similar remnant at an altitude of 560 feet or more is found on the north side of the valley of the East Fork of the Little Miami, some two miles east of Milford. It is only to be expected that the valley of the East Fork would be obstructed by the valley train along the Little Miami. Probably the former was in large part filled with silt from its own basin which has been since removed. A similar instance is found in a small valley one mile south of Terrace Park.

PLATE VIII.



A.—Erosion topography on Banklick Creek northwest of New Burlington. The Illinoian drift is here so thin as not to affect the topography.

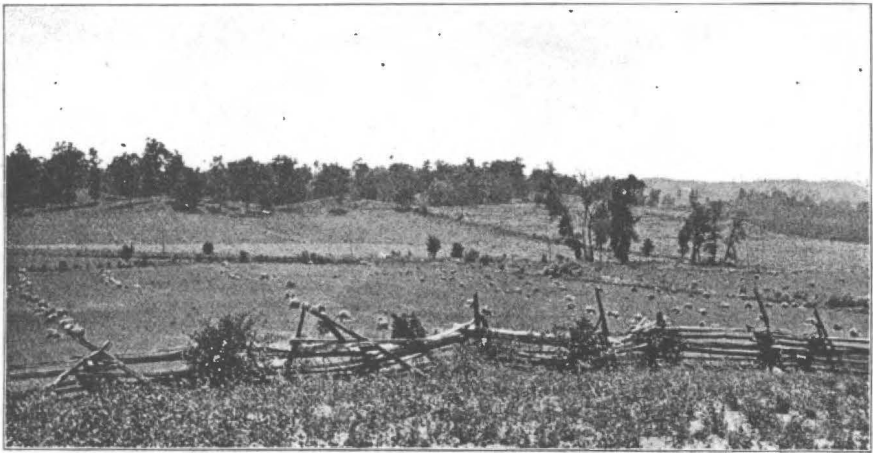

B.—Kames near Camp Hageman. These hills are as left by the glacier without subsequent erosion. (See p. 155.)

Two of the best examples of such silt terraces are found in the eastern tributaries of the Miami. The valley of the west branch of Taylor Creek, which joins the main stream opposite Miamitown, is largely occupied by such a silt deposit, which has been exposed at various places by the grading of the Chesapeake & Ohio Railroad (C. C. & L.) and by stream erosion. Here the fine silt in the small valley becomes first sandy, then gravelly, as it is seen in successive exposures nearer and nearer to the main valley. Doubtless the silt deepened in the side valley at equal pace with the deepening of the sand and gravel outwash in the main valley, the currents in the latter affecting the water in the former only a short distance from the mouth. Jordan Creek which enters the Miami two and one-half miles north of Cleves has some terraces which are remnants of similar filling.

An excellent example of what is probably the same feature is seen in the valley of Ludlow Run, a small northern tributary of Mill Creek, followed by the Cincinnati, Dayton & Toledo Traction Line west of Spring Grove Cemetery, Cincinnati. No remnant of the Mill Creek Valley train at full height is found so far down the valley, but less than three miles to the northeast is the excellent terrace near Bond Hill, already described. The surface of this is above 540 feet. It may well be that this filling extended down the valley far enough to obstruct the mouth of Ludlow Run. The consequence of such obstruction would be the aggradation of the side valley with silt from its own basin. The silt terrace is best preserved and exposed about one-half mile north of the terminal station of the traction line. Here it consists of finely laminated silts interbedded with more sandy layers. The uppermost silt layers abound in calcareous concretions, and in some of the layers are small coiled shells. The surface of this terrace, already somewhat lowered by erosion, is 540 to 545 feet above sea level. It is not entirely certain that it is not of the same formation as the silts lower down in Mill Creek Valley already discussed (p. 152). Its sandy layers and its greater altitude seem, however, to indicate wash from up the valley rather than subsidence from backwater of the Ohio. (Pl. VII-A.)

**Kames.**—Among deposits made by glacial waters at the edge of the ice, the most important are the kames which cover about two square miles centering at Camp Hageman where the Cincinnati, Lebanon & Northern Railroad crosses the old pre-glacial valley of Todd's Fork. These are abrupt gravel hills, some of them rising 100 feet above the flat valley floor, and affording the most striking morainic topography in the region. Their material is coarse and fine gravel and sand. Much of it was confusedly crossbedded when laid down (see p. 47) and large masses have since slumped, perhaps when the ice melted away, so that the bedding is now very confused (Pl. V-B). Many of the individual stones exceed one foot in diameter and a considerable proportion of the materials is of crystalline rock from the far north. Nowhere is the lithologic variety of the younger drift better illustrated.

The exact circumstances which brought about so large a deposit of water-laid material at this place are not apparent. The kames were of course built when the edge of the ice was at this place. In general, however, it is safe to say that where a not very thick ice sheet crosses obliquely so large a valley as that of the former Todd's Fork, there is apt to be a depression of its surface corresponding to that of the ground beneath. Both the surface drainage and the subdrainage of the ice are likely to be concentrated along such a line. Moreover, the chances of an irregular and locally indented edge of the ice are greatest where disrupted in crossing a valley. All these conditions favor kames. (See p. 108.)

Another good group of kames, but inferior to those at Camp Hageman, stretches from near Schencks Station, south of Hamilton, to beyond Furmandale. They lie mainly in a narrow north-south belt to the west of the Mill Creek Valley Traction Line, but are crossed by that line at Furmandale. The highest of these rise about fifty feet above the surrounding flat.

The circumstances giving rise to kame deposits at this place are apparent. The ice sheet moving south across the broad valley came against the upland which presents an angle to the north. There was a tendency of the ice to split on this headland and divide into two lobes, one going southeast, the other southwest. Probably it actually did this to some extent. The important thing here is a tendency to longitudinal crevassing, or at least to a separation between two lobes during the recession of the ice front. In such an indented front kame gravels would tend to accumulate. Another factor favoring kames at this place is the tendency to stagnation. This may indeed be the most important factor. Cracks in stagnant ice enlarge by melting and furnish appropriate recesses or pockets into which glacial waters carry their load, and where they leave it partly supported by ice walls. In the gravel pits in these kames the beds may be seen bent, broken, and faulted by the withdrawal of the supporting ice.

On these kames near Furmandale are thin patches of true loess, containing the ordinary loess fauna. It is noteworthy because of its occurrence on the younger drift. As a vast area of valley bottom lies to the west (windward) it will be observed that this was an appropriate place for the accumulation of loess according to the principle stated on page 139.

#### *Local Drainage Changes*

The great changes in the drainage of this region were probably all made during the first glaciation. Certain minor changes which are of interest seem to be connected primarily, if not exclusively, with the later advance of the ice.

**Narrows.**—Fourmile Creek is a western tributary of the Miami

near the northern edge of the area. It follows essentially its old pre-glacial course, generally between bluffs one-half mile to one mile apart. Its old valley is, however, filled with alluvium (partly glacial outwash) to a depth of 150 to 200 feet, and the river runs over this material. This is known partly by the depth of the filling in the Miami Valley which necessarily raised the mouth of its tributary, and partly from wells in the valley itself. At Oxford (just beyond the boundary of this area at the northwest) a well near Fourmile Creek was drilled through 187 feet of alluvium before reaching bed rock. Running over this material, the stream, while confined to its old valley, is not in its old channel. Locally it has meandered so near the bluffs that rock is exposed in its present channel. Several fords, and at least one bridge, are located at such points. The only marked dislocation from its former trench is two or three miles west of Darrrtown. Here the stream makes a sharp bend to the south and runs some distance in a gorge, which, at the narrowest place, has just the width of the stream. The gorge is more than 100 feet deep and is cut 30 feet into the bed rock. It is evident that the stream has here been crowded far up on the south side of its former valley. The hills within the bend on the north side are, so far as seen, entirely of drift, and, no doubt, obscure the old valley. Indian Creek is similarly crowded to the south at Bunker Hill and flows in a similar rock gorge, while elsewhere it follows its old trench now deeply filled, but bounded by its old bluffs one-half to three-fourths of a mile apart.

Simpson Creek is a small stream three or four miles long which flows east by north and enters the Little Miami at Foster. It has its upper course outside the area of the later drift and in a wide open valley. The last mile of its course is through a narrow and rocky valley which plunges steeply into the Little Miami. The interpretation here, as in the cases mentioned above, is that the lower course was crowded southward by the ice. This case is of interest because of the excellent contrast between the deeper and more fertile Wisconsin drift on the north and the thinner, silt-covered, more eroded, and less fertile older drift on the south. As in all the other instances cited of minor drainage changes, erosion in the new portion of this valley has exposed a good section of the underlying rock.

**Lakes.**—Where the edge of the ice rested against high uplands, some of the smaller streams were ponded, and the resulting ponds or lakes were partly filled with lacustrine sediments. On Banklick Creek in Colerain Township, Hamilton County, an interesting record of such conditions has been preserved. Here the Wisconsin ice sheet, coming from the north, covered only the edge of the upland south of the Miami, thus obstructing the north-flowing creeks. The ponded waters of the Banklick here rose to a height of at least 690 feet, that being the approximate level of the deposits made. This lake was filled in its central

portion with sand and silt, and near its edge with sand and gravel. Near the bridge at the west side of section 7, the creek has cut into its bank, making an exposure forty-five feet high. Four beds of alternating sand and silt are shown, the topmost bed being silt. The sand is much crossbedded. Apparently the dip of the crossbedding is down the valley toward the north. This would indicate considerable current in that direction, probably during intervals when the ice dam was not effective. A number of small remnants of deposits at the same level are found farther up the valley.

The West Fork of Mill Creek flows north from Mount Airy to near New Burlington, where it turns and takes an easterly course to near Glendale. Its upper course is outside the limits of the newer drift sheet. In its eastward course it enters the area of the newer drift about two and one-half miles southwest of Glendale, in the northwest corner of section 16, Springfield Township. For nearly a mile east of that point the creek runs in a narrow valley 75 to 150 feet deep, which is locally a sharp gorge cut many feet into the solid rock. This is due to the local crowding of the stream to the south out of its old valley. At the end of this gorge it again finds its old valley, or that of another pre-glacial stream, and follows this to its junction with Mill Creek proper. The ice, during its presence, and after that for some time the drift, ponded the upper stream, forming a lake, whose level was a little below 700 feet. This lake was almost filled with silt, remains of which are now well shown in the flat ground in the northwest corner of section 16. Most of the valley above this place is so narrow that the stream has since carried out the lacustrine silt, but small remnants are still found. Along a small northern tributary once known as Whiskey Run, about one mile east of New Burlington, the silt appears in the banks. About one-half mile above its mouth the skull and two teeth of a hairy mammoth (*Elephas primigenius*) were found. This animal flourished in late glacial time. The fossil was found embedded in gravel just beneath the lake silt and a little below the level of the stream.

Sharon Creek is a small stream four or five miles long which flows southwest, and emerges from the east bluff of Mill Creek Valley at Sharonville. Its upper course lies in a broad valley just at the edge of the early Wisconsin ice sheet. About one mile above Sharonville it suddenly enters a sharp gorge more than 100 feet deep, and cut fully fifty feet into rock. The Pleistocene map shows that at this place the glacier pushed to the southeast in a small lobe which crossed the course of the creek and crowded it out of its old valley. The former valley is now filled with drift and cannot be seen. The valley above the obstruction became a lake, and was filled with lacustrine clay to an altitude between 760 and 770 feet. Some of this clay is finely laminated and very plastic. Most of this filling was accomplished before the ice withdrew. This is known from a section just above the rock



A revived stream, tributary to West Fork one mile above Cumminsville. Note the narrow gorge cut in the older broad valley since rejuvenation.  
(See p. 159.)

gorge where a sheet of till rests on the clay. Most of it, however, remains uncovered. The cutting of the rock gorge was necessarily slow as compared with erosion in clay. Hence the stream above the gorge has not only trenched the clay to a depth of thirty feet, but widened this trench to about 400 feet.

## THE RECENT EPOCH

### *Changes on the Uplands*

**Development of Drainage.**—The Pleistocene or Glacial epoch ended with the retreat of the Wisconsin ice sheet, and all subsequent time is known as the Recent epoch. The geological work of this epoch has been largely erosion, but there have also been deposits, especially of alluvium. These include that which is now forming on our flood plains and that which covers the alluvial terraces lower and younger than the Wisconsin outwash. The changes brought about during this epoch are therefore similar to those described after the Illinoian stage. The streams which run over the drift sheet are, in their present cycle, largely consequent, that is, they follow courses determined by slopes which they *found*. In the older chapters of their history, many or most of these valleys were no doubt subsequent, that is, due essentially to the work of the stream instead of being found and followed by it. The larger side streams have altered the original troughs which they followed, by carving within them stream-made valleys with bluffs, in some cases separated by flats, but the smaller drainage lines with temporary streams are not true stream valleys. They are purely *constructional* features. In some cases gullies have developed either in the constructional troughs or on their slopes. These have been growing headward, thus lengthening some of the original valleys or increasing the number of tributaries.

**Revived Streams.**—Certain valleys immediately tributary to the great valleys, show the features of recent revival very strikingly. One of these is the valley of West Fork which enters Mill Creek at Cummins-ville. Up stream from the schoolhouse (about one mile west of Cummins-ville) the immediate valley of this stream is a gorge from ten to thirty feet deep, cut largely in the Eden shales. The cutting is so fresh that the walls are at many places precipitous, and the channel shows a succession of small falls or rapids where the stream passes over the limestone beds which occur at intervals in the shale. The level in which this gorge is cut is itself the bottom of an old valley more than 200 feet deep and one-half mile wide at the top. The relatively level bottom is from several hundred to 1,000 feet wide. These are the prominent features of a revived stream. (See p. 99, also Fig. 41 and Pl. IX.)

It is plain that at a time not very remote, the stream was flowing



at the level of the top of the present gorge, that is, at the level of the floor of the broad valley. This floor near Cumminsville is well below 500 feet, and is 400 to 600 feet wide. It therefore represents a well established graded course at a time later than the Wisconsin stage, for at the close of that stage the mouth of this valley must have been filled to the level of the partly filled Mill Creek Valley. Up stream from Cumminsville the old valley floor rises with a normal stream profile. One-half mile above Cumminsville the present stream flows at the old level, not being entrenched. One-half mile farther up, the stream flows in a vertical sided gorge thirty feet deep and its tributaries do the same. Up stream from that point, the depth of the new gorge gradually decreases.

It is plain that the stream does not now need so steep a gradient as it did in its former condition. This in turn indicates that the stream has greater carrying power and cutting power than before. It is therefore cutting down its upper course without changing the level downstream, thus flattening its profile or reducing its gradient. This much is certain, though the exact reason for its increased efficiency may not be clear. Probably it receives no more water than it did in the former condition. On the other hand it is plainly handling much larger stones than formerly. This may be seen by comparing the great slabs of limestone in the present channel with the rubble which occupied the channel at the higher level (Pl. III). The natural assumption is that since the removal of the once luxuriant forests the run-off is much more prompt, causing greater freshets, and thereby increased power; for it is well known that, so far as erosive power is concerned, a given amount of run-off is vastly more effective if concentrated into freshets than if discharged at a uniform rate. This supposition as to the reason for the "rejuvenation" (p. 99) of West Fork agrees with observations on certain other creeks in this area, some of which (though much smaller than West Fork) have been known to cut canyons ten feet deep in less than fifty years since the removal of the forests.

#### *Changes in the Great Valleys*

The post-glacial work of the large streams has consisted mainly in removing most of the material of the valley trains. In doing this they have lowered their own levels from 30 to 200 feet. If all the larger valleys were again filled up to the level of the present terraces of Wisconsin age, the amount of material thus used would be that which has been carried away since the glacier departed. Along the Ohio this would mean a fill of 190 feet in the axis of the valley. In the Miami Valley at Hamilton it would require a fill of forty or fifty feet.

The work of deposition since the last glacial stage, has been done mainly by streams on their flood plains (see p. 92). In this way they

have coated their bottom lands with sand and gravel to a depth somewhat greater than that of their channels, and have spread over this a sheet of loam ranging in thickness from zero to ten or fifteen feet.

### *Work of Wind*

Wind has not performed much work of geologic importance since the last glacial stage, but it has raised some sand dunes and even deposited a little loess. The former are exemplified at Ludlow, Ky., where, unfortunately, they are being fast cut away in excavation for gravel. They partly covered the gravel terrace of the Wisconsin stage between the railroad yards and the Lagoon, rising ten to fifteen feet above the gravel surface. It is significant that the activity of the wind in recent geologic time should thus be attested in the same vicinity where there is such abundant evidence of its work in the epoch when

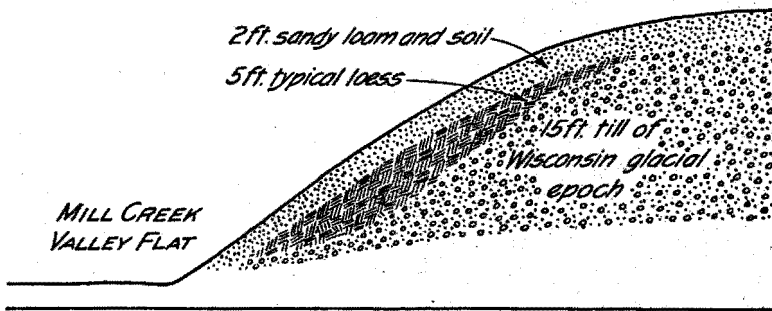

Fig. 52.—Loess on till of Wisconsin age at Reading.

the loess was deposited. It would not be surprising to know that the loess on the uplands to the east had again deepened at the time the dunes were made.

What seems to be dune sand covers a small area in the Mill Creek Valley north of Reading and east of the International Agricultural Works. The area thus covered is the south end of the elliptical spot shown on the map as underlain by till of Wisconsin age. The sand here covers the mildly rolling surfaces three to five feet deep. Its grains are well rounded and consist of quartz and other minerals derived from the igneous rocks of the drift. Probably it was carried up by winds from the alluvial flats on the west.

That wind was an active agent in this valley in post-Wisconsin time is made certain by the presence of true loess resting on the newer till at the foot of the east bluff at the northern edge of Reading. It is identical in character with that at Covington and Newport, containing also small pulmonate shells. The deposit is from three to seven feet thick and may well have settled on the bluffs at the same time that the

heavier sand was drifting on the flats to the west (figure 52). The thin covering of loess on some of the kames south of Hamilton (p. 156) is exactly analogous to this occurrence.

From the economic standpoint, by far the most important geologic process since the glacier disappeared, has been the making of the soil. This has been accomplished on the newer drift by the weathering processes described in Chapter IV and by the intermixture of decaying vegetation. The soils of the area are described in Chapter VIII.

## CHAPTER VII

### WATER RESOURCES

#### STREAMS

The water resources of a region include its running water or streams, its standing water or lakes, and its ground water, the source of wells and springs. Of these three, the second is absent in this region. There are no lakes or even ponds, except artificial ones made by building dams across water courses. The streams are highly important and the ground water most important of all.

The chief uses of streams are four: water supply, navigation, power, and irrigation. The last named, which is the chief use in the arid west, need not be considered here; and water power is not important in this area as compared with the other two uses.

#### *Navigation*

**Ohio River.**—Of all streams in America the Ohio has been the most used for navigation. In the latter part of the nineteenth century traffic by water decreased greatly, not only on rivers, but on canals as well.

In recent years, because of the vast amount of freight to be carried in the United States, and the relative cheapness of water transportation as compared with railroad transportation, there has been a great revival of interest in inland waterways. One river boat has been known to tow in barges 70,000 tons of freight at one trip. This is equal to the load of 2,333 modern freight cars, making a train more than fifteen miles long.<sup>1</sup> The cost of moving coal down the river is from one-fifteenth to one-fourth the cost of carrying the same coal by rail. Because of such facts as these, the United States Government has for many years been building dams to canalize the Ohio and thus provide for a constant depth. Most of the work previous to 1904 was near Pittsburgh, and was designed to provide for a minimum depth of six feet. Operations since that time have contemplated a nine-foot stage.

The essential feature of canalization is the maintenance of a certain minimum depth, however small the discharge may be. In summer,

<sup>1</sup>For these and other interesting figures see pamphlet entitled "The Michigan and Erie Ship Canal," by Frank B. Taylor. Published by the Toledo, Ft. Wayne and Chicago Deep Waterway Assoc., Ft. Wayne, Ind.

when the discharge is small, the water instead of falling lower simply moves more slowly. This is effected by means of dams placed sufficiently near together so that the level of the stream between two consecutive dams is essentially flat. In this way any desired depth may be maintained by building the dams high enough; but it is to be remembered that, with increased depth, the water moves correspondingly slower between dams.

The total number of dams contemplated between Pittsburgh and Cairo is about fifty, and the entire cost will be somewhat more than sixty million dollars. The first dam built to retain nine feet of water was completed in 1911 at Fernbank, twelve miles below the suspension bridge at Cincinnati. The crest of this dam is sufficiently high to maintain a pool of water with an essentially horizontal surface and not less than nine feet deep, extending up stream several miles beyond California. The next dam to be constructed near Cincinnati will be at the upper end of this pool.

**Miami River.**—The Miami is not now navigated, but in the earlier years of settlement many flatboats plied as far north as Hamilton. It is still classed as a navigable stream, and as such is under the control of the federal government. The amount of water which it carries is many times what is necessary for a deep canal, but, in comparing the canalization of this river with that of the Ohio, it must be considered that the average fall per mile of the Miami is eight times that of the Ohio. Eight times as many dams of the same height would therefore be necessary in order to maintain the same depth of water.

**Other Streams.**—As to navigation, the Licking is similar to the Miami, but its lower course, lying within a great industrial community, is somewhat used as a harbor. In a similar way, Mill Creek, though a very small stream, offers opportunities for the making of a great harbor by the artificial enlargement of the channel in its lower course. As there is already a great concentration of railroads in this valley, it is not improbable that the opportunity of a great harbor by their side will some day be found one of the greatest commercial advantages of this locality.

#### *Water Supply from Streams*

**Ohio River.**—As a source of water supply the Ohio is quite as important as for navigation. The city of Cincinnati pumps from the river fifty-three million gallons daily for its city water systems. Fortunately for this purpose the water of the Ohio is relatively soft. Its headwaters are in the Allegheny plateau whose rocks are in large part sandstone and shale. Calcareous rocks are very subordinate. An average analysis of the river water at Cincinnati shows that it carries in solution only 120 parts of mineral matter in 1,000,000 parts of water.

The hardness, or content, of dissolved solids in the Ohio should

be contrasted with that of the Mississippi at St. Louis, which has 269 parts per million, the Missouri at Kansas City, which has 426, and the Miami at Dayton, which has 289.

Like all great rivers, the Ohio carries mud in suspension, though not so much as the Mississippi below St. Louis, and only a fraction of the amount carried by the Missouri, which furnishes the larger part of the Mississippi mud. The average amount of mud in the water of the Ohio is 230 parts per million.

That the softness of the Ohio water is due to the rocks which underlie its headwaters, is shown by the character of the Allegheny at Kittanning, Pa., which carries but eighty-seven parts of dissolved matter per million. The Monongahela, at Elizabeth, Pa., has eighty-one parts per million.<sup>1</sup> Much of the dissolved matter which appears in the river at Cincinnati is derived from tributaries in Ohio.

The municipal supply for Cincinnati is pumped from the river at California, nine miles above the suspension bridge. It is first allowed to stand in large open basins where a part of the mud settles. It is then filtered through sand, after adding a small amount of sulphate of iron and of lime, to cause the clay to flocculate, that is, to form small flakes or granules. After filtering, the water passes into other basins from which it enters the city mains. Although the filtering process is calculated primarily to remove the mud rather than bacteria, experience shows that most of the latter are removed at the same time.

**Miami River.**—No other stream in the area is used as a source of water supply. Cities not on the Ohio derive their water from wells. It is instructive, however, to compare the quality of the water in other streams with that of the Ohio. The Miami gathers its waters from western Ohio where the underlying rock is largely limestone. As shown on page 107 the overlying glacial drift is similarly calcareous. The water of this river at Dayton shows 289 parts of dissolved solids in one million parts of water. The water is therefore more than two and a half times as hard as that of the Ohio at Cincinnati. The water of the Miami at Hamilton<sup>2</sup> is fifty per cent harder than at Dayton, and the water of the Little Miami, near its mouth, is similar to that of the Miami at Hamilton.

#### *Water Power*

The only use of water power in this area is at Kings Mills on the Little Miami. At this place one of the large powder factories of the United States is operated in part by water power, 700 horsepower being developed and available for nine months in the year. At every

<sup>1</sup>Fuller, M. L., U. S. Geol. Surv. Water Supply Paper No. 259, p. 215.

<sup>2</sup>Fuller, loc. cit. p. 215. The figures given here for Cincinnati and Dayton are averages of many analyses made in various seasons of the year. The others represent fewer analyses and are therefore less exact. It should be remembered that river waters are much harder at some times than at others.

dam, power is made available when the stream is at suitable stages. This is true of the large dams under construction in the Ohio. The use of power thus developed has not yet begun.

### *Floods*

**In the Ohio.**—A physiographic question of great interest in this area is that of floods. The Miami Valley was perhaps the chief sufferer in the floods of March-April, 1913, when the direct property damage in Ohio alone was conservatively estimated at \$143,000,000.

The Ohio at Cincinnati is said to be in flood when the water reaches a depth of fifty feet on the gauge. From 1862 to 1913, fifty-one years, this depth was surpassed forty-three times. The maximum height was 71.1 feet on February 14, 1884, but on April 1, 1913, the water fell short of that height by only 1.3 feet. Five years may pass without a flood, as from 1870 to 1875, and again there may be two destructive floods in one year, as in January and April, 1913. It should be understood that the selection of a height of fifty feet as the flood limit is purely arbitrary. Had a lower stage been selected as the limit, the number of floods would be greater. At that stage damage may be said to begin. At a stage of 63 feet passenger trains fail to reach the Little Miami (Pennsylvania) station, and at 53.5 feet the Union Station is abandoned. Before that stage is reached the handling of freight is largely stopped.

**In the Miami.**—Previous to 1913 the Miami received no attention as a stream liable to dangerous floods. The highest stage recorded at Hamilton was in 1898, when the river reached 21.2 feet. On March 25, 1913, the stream suddenly passed that record and rose with great rapidity to a height of 34.6 feet, which was passed at three o'clock a. m. March 26. The experience at Dayton was similar. In both cases areas were deeply flooded which had always been classed as terrace lands and had never been considered liable to overflow.

**Cause of Floods.**—The floods of this district are caused either by excessive rains or by melting snows. The greatest melting of snow is, of course, in the early spring or late winter. Excessive rains may come at any time of the year, though they are a little more frequent in spring and summer. Among the conditions favoring floods are frozen or very wet ground. Percolation is thereby hindered and prompt run-off is made necessary. All the conditions for floods are therefore most likely to be met in the late winter and spring. Of the forty-six floods on record at Cincinnati only three occurred outside the months of January, February, March, and April.<sup>1</sup> These three were in December,

<sup>1</sup>A convenient summary of these floods is contained in U. S. Geol. Surv. Water Supply Paper No. 334—The Ohio Valley Flood of March-April, 1913—by A. J. Horton and H. J. Jackson.

1847, May, 1865, and August, 1875. Some of these floods have been aggravated by the breaking of ice gorges, and by the narrowing of the river channels by bridges and "made land." The breaking of levees or of reservoir dams has not affected this region.

The great flood of 1884 illustrates a combination of all conditions operative here—heavy rains combined with melting snow on frozen ground. The flood of 1913 was due purely to excessive rains on ground already wet almost to saturation.

**Flood Problems.**—The complex question of the prevention and control of floods cannot be taken up here, except to mention and classify the different lines of effort. They fall into two distinct categories, flood prevention and flood control.

*Outline of the Problem of Floods*

Flood prevention.

Increase of percolation by

Methods of tillage

Preservation of vegetation

Terracing

Reservoirs to retard run-off

Flood control by channel improvement

Deepening

Broadening

Straightening

Levees

**Increase of Percolation.**—The water which falls as rain is disposed of in three ways, by immediate evaporation, by percolation, and by run-off. Anything which increases or decreases one of these processes affects the other in the opposite direction. Man cannot directly control evaporation very much, but he has considerable power over percolation and run-off.

The flow of streams at ordinary stages is supplied chiefly by springs and seepage. Water thus derived from the ground went in as rain some days, weeks, or even years earlier. Such water constitutes the *permanent flow* of streams. Over against this is *storm water*, which runs off without entering the ground. The body of a flood is of this character. It is important to remember that floods are made up essentially of *water which has failed to percolate*. How to increase percolation is therefore the most fundamental problem in flood studies. It is also a problem of the greatest magnitude in agriculture, which affects the human race far more vitally than floods. The United States Department of Agriculture is devoting much time and effort, already with some degree of success, to teach farmers on hilly lands to plow in such a manner as to assist percolation and retard run-off instead of the



opposite. This is done by plowing around the hill in horizontal lines instead of up and down hill. The practice is known as "contour plowing."

All vegetation tends to retard run-off and increase percolation. Fortunately, slopes too steep for profitable agriculture support just as good forests as does flatter land. The conservation of forests on all steep slopes is now being strongly urged and, to a limited extent, applied. This is very wise for more reasons than one. It should not be forgotten, however, that for one acre in forest there are many acres in crops or meadow, and the preservation of such vegetation so as to avoid washing of the soil and gulying is profitable, not only from the standpoint of agriculture, but from that of floods.

Most hilly countries come sooner or later to the practice of terracing. As the population of the United States increases, and farming becomes more differentiated, and intensive agriculture displaces extensive attempts where they do not pay, terracing will be practiced more and more. This will be done primarily for agricultural reasons, but in decreasing immediate run-off it will also tend to decrease floods.

**Reservoirs.**—A reservoir is constructed by building a dam across a valley, usually at a place where the valley is narrow and above which it is wider. Within limits the deeper the valley the better. A project to prevent floods by reservoirs provides for many such dams in tributary valleys. When used simply to prevent floods they are supposed to be closed only when the main stream below is approaching flood height. The water is then to be held back until it can safely be released. The plan contemplates that in this way an excessive rain, instead of running off in three or four days of flood, may be disposed of in several weeks without flood. Such a plan for the upper Ohio (above Pittsburgh) is approved by many eminent engineers.<sup>1</sup> There is no lack of reservoir sites in eastern Kentucky, West Virginia, western Pennsylvania, and eastern Ohio, that is, in the Allegheny plateau. In western Ohio, that is, in the Till Plains, the case is different. There the valleys are not only fewer but shallow, and it is necessary to flood wide areas in order to retain enough water to affect great floods.

Despite these difficulties the State of Ohio has authorized the construction of an extensive system of reservoirs in the Miami drainage basin to protect Dayton and other cities from floods. The plan of preventing floods by wholly artificial reservoirs is not yet in operation on any American stream. It is complicated with questions of

<sup>1</sup>The question of reservoirs to prevent floods has been thoroughly investigated by a commission under the auspices of the Pittsburgh Chamber of Commerce. The final recommendation of this commission was for a system of reservoirs supplemented by a river wall. The report of this commission is a large volume containing a vast amount of information of general interest to students of floods. It also contains an exhaustive bibliography on the subject of flood prevention in this and foreign countries.



A.—Flood at Hamilton, March 26, 1913. (U. S. Geol. Surv. Water Supply Paper 334.)

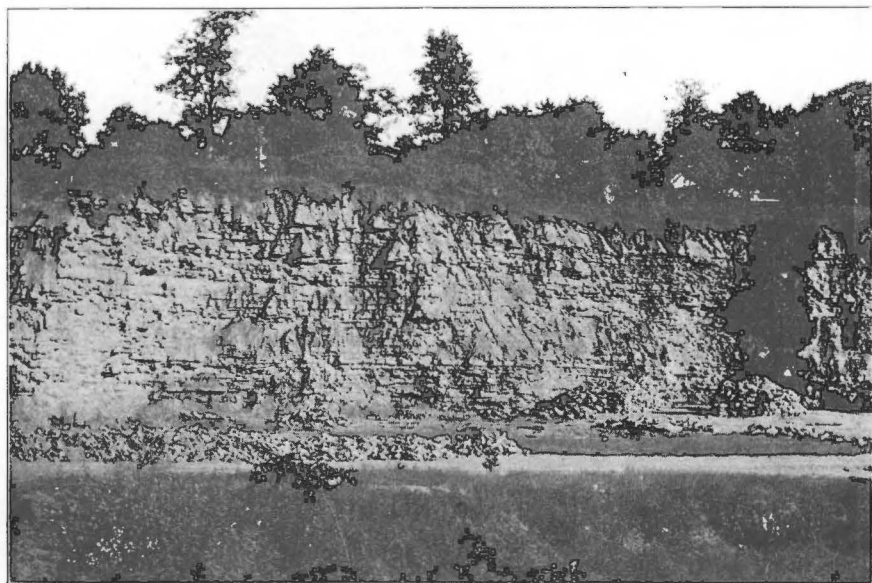

B.—Quarry in the Fairview formation, Observatory Road, Cincinnati.

navigation, water power, and water supply, all of which must be taken account of in a comprehensive plan. Further difficulties arise from a conflict of local and general interests. Large rivers traverse more than one state, so that the only authority sufficient to control such an enterprise is the national government. There is a further question as to whether the purely public benefit would justify the expense. If the benefit which would accrue purely to individuals be added to that of the public, there can be no doubt that the resulting gain would greatly exceed the cost. No project has yet been seriously considered for the prevention of floods by this means at Cincinnati, or at any other place which receives the drainage from so vast a drainage basin as that which lies above Cincinnati. The prevention of floods by reservoirs is practiced to a considerable extent in Europe in drainage basins of a few thousand square miles.

**Control of Channels.**—The control of floods by alterations of stream channels has been much more practiced in the past than any kind of flood prevention. Levees have long been built and channels straightened to provide greater fall and more speedy discharge. Channels may be deepened where the amount of fall permits. The control of channels has become a specialized branch of engineering science, because in altering the channel at one place the effects farther down stream must be considered.

Of recent years an increased amount of attention has been given to the obstruction of streams by bridge piers, and the narrowing of the channel by artificial filling and by buildings. In doing the latter, not enough consideration has been given to the fact that intermittent floods are normal occurrences on a stream which does not flow through lakes. It is not necessary to appeal to human records to ascertain this. The existence of flood plains covered by silt is the final proof. In view of this fact it would seem reasonable that the human race should find out how much room is necessary for the movement of recurring excess waters, and then adapt itself to the circumstances. Perhaps the largest factor under the direct and immediate control of the public is the artificial narrowing of stream channels.

## UNDERGROUND WATERS

### *General Principles*

**How Contained.**—Ground water, as the name implies, is water in the ground. It is contained in pores and larger cavities and passages in both bed rock and mantle rock. The pores may be very small like those in our shale or our limestone, or they may be such as exist between sand grains and pebbles in gravel, or between the crumbs of soil. Ground water also exists in cracks and between beds of rock which fit as closely as the leaves of a book tightly pressed. Again,

these cracks, either between beds or across them, may be enlarged by solution, making passages. (See Fig. 30, p. 72). In the limestone of this region there are many such passages from the size of a lead pencil to that of a man's arm. From this size up to that of Mammoth Cave there are all gradations.

**The Water Table.**—All such pores and passages may be either full of water or empty, or merely wet on the sides. Near the surface

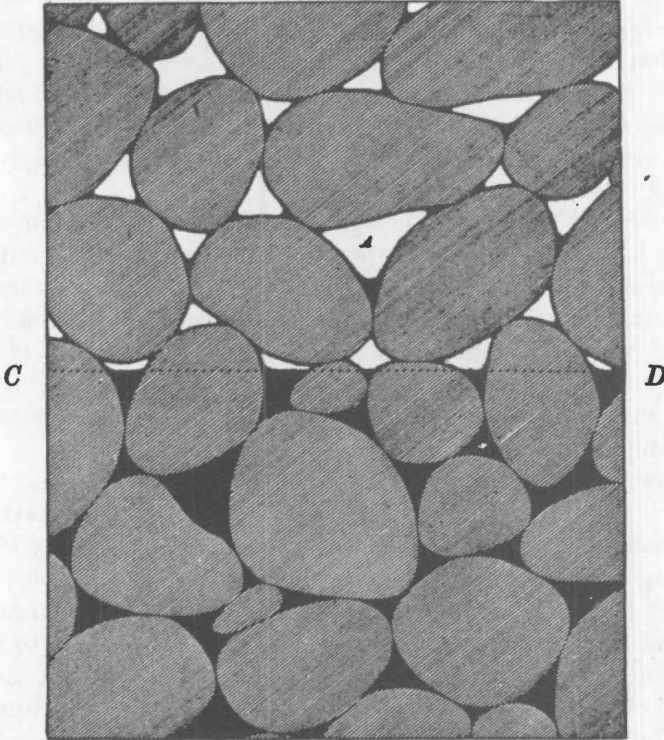

Fig. 53.—Ground water in pores of sandstone. Below the water table, CD, the pores are full. Above that level, capillary water coats the grains and is concentrated in corners. The pores are otherwise filled with air. If the coating of the grains in the upper half of the figure is assumed to be calcite, iron oxide, or silica, the diagram will serve well to show how sand grains are cemented into a sandstone.\*

they generally contain air, the moisture simply coating the grains or lining the cavities. Beyond certain depth the pores are full. If a hole be dug or drilled beyond that depth it will fill with water. If the rock into which it is drilled has only very small pores, the hole will fill with exceeding slowness. Nevertheless, it will fill in time if the moisture is not evaporated as fast as it comes in. This level, beneath which the pores are full, is called the level of ground water or the "water table." In valleys the water table is near the surface, and beneath

\*U. S. Geol. Surv., 21st. Ann. Rept., Part IV.

hills it is generally far below the surface, but not at so low a level as beneath the adjacent valleys. The relation between the surface of the ground and the water table is shown in figure 54.

Ground water is constantly acted on by gravity which tends to flatten out the water table. Where an impervious rock below the water table crops out on a hillside, the ground water rests on it, following its upper surface and issuing as a hillside spring. Near Cincinnati, the Eden shales afford less passage for water than the alternating limestone and shale of the overlying Fairview; hence it is quite common to find springs and seepage at the contact of these two formations about half way up on the bluffs.

In a similar way, the flattening out of the ground water within the hill or upland causes it to enter the stream channel in the valley.

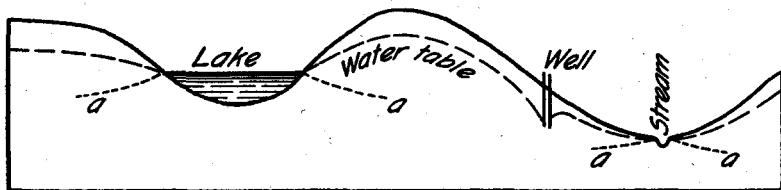

Fig. 54.—Diagram showing relation of the water table to surface slopes in a humid climate where lakes and streams are permanent. The ground water moves down the slopes of the water table, hence toward the lakes and streams. The dotted lines a, a, indicate the local slopes of the water table away from temporary lakes and streams in an arid climate. In the immediate vicinity of the well, excessive pumping has temporarily depressed the water table.

This is the only source of supply for a stream between rains. It is a general principle that streams do not become permanent until their channels are cut below the water table.

Between impervious beds, the effect of gravity on ground water is to cause it to move laterally as it would in a pipe, from the end where the level is higher toward some outlet at a lower level. This is a fundamental principle in artesian wells, and is well illustrated in the artesian conditions at Cincinnati described below. (See p. 175.)

Ground water is constantly being exhausted by another process, namely, evaporation. This evaporation is not mainly at the water table but at the surface of the ground above. It is lifted from one to the other by capillary attraction.

As ground water is being constantly depleted in these ways, so it is intermittently replenished by rains. There is evidence to show that the level of ground water in this part of the United States has subsided a number of feet since occupied by civilized man.<sup>1</sup> In some

<sup>1</sup>McGee, W J—Wells and Subsoil Water. U. S. Dept. of Agr. Bureau of Soils. Bull. 92, p. 178, 1913. McGee estimates this lowering in Ohio at 11.5 feet and in Kentucky at 10.7 feet.

cases this is desirable, as where swamps are drained, but in general it is a serious loss of a great natural resource. The drying up of some wells, and the necessary deepening of others, is the least of the losses. The real loss consists in the decreased moisture supply for crops. As the water table gets farther below their roots, the rise of moisture by capillarity becomes slower, and the ability to resist drought becomes less and less. It would not be unreasonable to estimate that a lowering of the water table five feet over the state of Ohio would be equivalent to the total loss of a year's crops with all the live stock dependent on it.

For this reason, as well as to prevent floods (see p. 167), it is highly important that farmers should favor percolation by plowing always on horizontal lines, and by keeping suitable vegetation on all slopes steep enough to wash.

**Wells.**—Wells are classified as surface wells and deep wells. This distinction has no reference to absolute depth. A surface well is one fed by ground water which is in direct communication with the surface, that is, it may have percolated straight down (even though slowly). The level of water in such a well marks the local level of the water table. It is higher in wet seasons than in dry. Such wells are generally shallow, but they may be several hundred feet deep if no impervious bed is struck at a higher level. Deep wells derive their water from beneath an impervious cover; it may be very near the surface, but in all such "deep wells" the water must have entered the ground at a distance—it may be a few miles or a few hundred miles. Very frequently such water is found to be under pressure or "head" and rises in the well. This is because it stands higher at the place of entrance than the level at which it is struck. It may even overflow at the mouth of the well. This was the original conception of an *artesian* well. As the word is now used, it is not necessary that the water should overflow or even rise to the surface, but only that it should rise by hydrostatic pressure, showing that it has been held down by an impervious cover. Generally speaking, such waters in humid lands contain more mineral matter in solution but less organic matter. Danger to health lies mainly in the latter.

#### *Water-Bearing Formations*

**Alluvium.**—Well waters, sometimes under more or less pressure, may be obtained from almost any of the formations within this area, but they differ greatly in the quantity of water yielded. More wells of large capacity are finished in alluvium (including that of glacial age) than in any other formation. All municipal supplies, except those taken from Ohio River, are from wells in the glacial outwash of the great valleys. Where this is of Illinoian age, as at Norwood, the wells may penetrate sheets of glacial till as well as sand, gravel, and clay, but the water is derived from the sand and gravel beds. Such

wells may strike water-bearing beds very near the surface, and many wells for domestic purposes go no deeper. In going deeper other water-bearing beds are pierced, and many wells derive water from three or four different beds. Frequently they go down to the underlying rock, and may even enter it a few feet, but the amount of additional water thus obtained from the rock is insignificant. Many manufacturing plants and other private interests have wells of the same kind as those which furnish municipal supplies.<sup>1</sup>

All such water is decidedly hard as compared with that of the Ohio. The total amount of mineral matter in solution in the latter is 120 parts per million, while water from the alluvium contains in general from three to six times as much.<sup>2</sup> This is to be expected in view of the calcareous nature of all the glacial drift including the out-washed gravel. It also emphasizes the fact that local ground waters are not derived from the streams, but, on the contrary, are moving toward them. Thus the Ohio becomes more and more hard as it proceeds.

**Surface Silt and Till.**—The surface silt rarely affords well waters because it is generally so thin that its base is above the water table. On the other hand, the base of the till is frequently below the level of ground water, and therefore saturated. Being essentially a clay formation its pores are small and the water moves through them slowly. Wells which stop in this formation have therefore but small capacity, but usually sufficient for small domestic supplies. Among farms on the uplands, more wells stop in this formation than in any other. The disadvantage of small yield is to some extent offset by the advantage of less contamination. The dense texture of the clay protects these wells better from surface impurities than a more porous material would. This advantage cannot be emphasized very strongly when the careless way is observed in which many farmers allow contaminated water to drain into the well from the top.

The supply of well water from the till is somewhat enhanced by the joints described on page 125. Water percolating through till also makes for itself small passages or tubes. In digging wells, or even post holes, water may sometimes be seen to gush from one of these tubes. Locally also there are pockets of sand and gravel from which the yield is good. In some such cases the water is found to be under a slight artesian pressure. The newer drift is on the whole better for wells than the older. It is generally less dense and more porous and is locally sandy. Well waters from the till are hard like those from the

---

<sup>1</sup>U. S. Geol. Surv. Water Supply Paper No. 259 by M. L. Fuller and F. G. Clapp, entitled *The Underground Waters of Southwestern Ohio*, contains the largest amount of information yet assembled concerning all wells in this vicinity. Chemical analyses are also given and the nature of the water-bearing formations is described.

<sup>2</sup>Dole, R. B.—*Water Supply Paper, 259, p. 203.*

alluvium, containing on an average at least five times as much mineral matter as the Ohio River water.<sup>1</sup>

**Maysville and Richmond Groups.**—Water supplies from the solid rock formations in this area are uncertain in both quantity and quality. From the standpoint of water supply, the solid rock formations of this area may be treated in four divisions, as follows: formations above the Eden shales, the Eden shales, the Trenton and underlying limestones, and the St. Peter sandstone. In the upper division, consisting of the Maysville and Richmond groups, both the limestones and shales are so dense that the water contained in their pores is almost unavailable. That which follows joints and bedding planes has freer flow. Joints in the limestone are thus frequently enlarged, as described and figured on pages 71 and 72. (See also Pl. IV-B). These are often nearly circular in cross section and may be four or five inches in diameter. The finding of abundant water in the fresh rock depends on striking some such passages below the water table. In a group of nearby wells, one well may strike such a passage at small depth, another at great depth, and another not at all. One well may yield abundant water and another little. One may show considerable pressure and another none. The outcome is always uncertain. Near the surface the bed rock is weathered and more porous, and the likelihood of striking water is correspondingly greater.

The water from this group is harder than that from the alluvium. In fact, since the edges of these beds abut against the alluvium in the great valleys, it is quite probable that much of the water in the latter is derived from these formations. Chemical analysis may show some common salt in these rock waters. In a few wells it is sufficiently abundant to spoil the water for drinking.<sup>2</sup>

**Eden Shales.**—The Eden shales illustrate the general principle, a highly important one in other lines of geology, that soft rocks do not fracture to the same extent as hard ones. Their fractures are mainly near the surface. Moreover, fractures in shale do not enlarge by solution like fractures in limestone. Between the density of the Eden shales on the one hand and the lack of enlarged joints on the other, they afford almost no water to wells. Only where the formation immediately underlies the soil and is in a weathered condition is there much chance of obtaining water, and then only in dug wells. Where the passage of ground water is slow, it is evident that much more water will issue from the large rock surface exposed in a dug well than from the small surface exposed in a drilled well.

**Trenton and Underlying Limestones.**—For 800 to 1,000 feet below the Eden shales the beds of the Trenton, Black River, and Stones River groups are composed largely of limestone. The water conditions in

<sup>1</sup>Dole, R. B., loc. cit.

<sup>2</sup>Dole, R. B., loc. cit. Various analyses on pp. 198-204.



these are essentially the same as in those above the Eden. Solution grooves and passages are perhaps still more prominent. They afford the only water available for wells. Unfortunately, the water from these formations is liable to be both salty and sulphuretted. It is frequently unfit for domestic use. In exceptional cases these rocks yield strong brines. The Eikenbrecker salt well at Ludlow Grove is 271 feet deep, and therefore stopped in the Trenton. Its water contains dissolved mineral matter, mainly common salt, to the extent of 98,222 parts per million, or nearly one-tenth of its weight.<sup>1</sup>

**St. Peter Sandstone.**—Below these limestones is the St. Peter formation consisting largely of sandstone, one of the most widespread

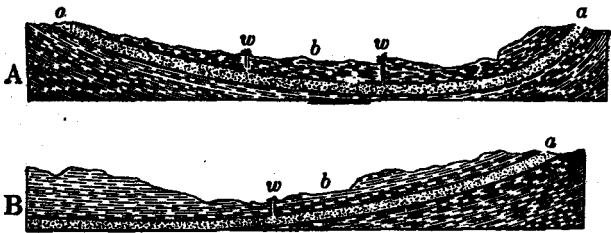

Fig. 55.—Conditions favorable for artesian wells. In the upper figure the porous bed is in the form of a basin; in the lower figure it merely dips, but there must be no natural outlet at its lower edge for the water which it contains. (After Salisbury.)

formations of the Upper Mississippi Valley. It yields a brine which is about one-third as strong as sea water, about one per cent of its weight consisting of mineral matter in solution. Common salt and sulphates are the chief ingredients. A number of deep wells in and near Cincinnati derive their water from this formation, but it is used only for mechanical purposes, such as cooling in the process of brewing and distilling.

An old analysis of the water from such a well at the Cincinnati Gas Works showed nearly one per cent of common salt, beside a considerable amount of lime and other salts.<sup>2</sup> A brine four times as salt as the sea was obtained from the same formation in a well at the works of the Champion Coated Paper Company at Hamilton.

#### *Artesian Conditions*

The St. Peter sandstone is the chief bearer of water under artesian pressure. While the chief water-bearing stratum is here 1,100 to 1,200 feet below the level of Ohio River, the formation comes to the surface in Missouri, northern Illinois, and Wisconsin. Probably most of the

<sup>1</sup>Dole, R. B., loc. cit., p. 204.

<sup>2</sup>See Dole, R. B., loc. cit., pp. 198 and 202.

water in this formation under Cincinnati entered at those outcrops, since the formation is overlain by many impervious beds. If this be true, the distance which it travels is about 350 miles. The surface of outcrop is about 850 feet above the sea. At Cincinnati the water rises to about 600 feet above the sea, or fifty to sixty feet above the street level in the business section of the city. This failure to rise to the full height at which it stands elsewhere is called by engineers "loss of head." This is due to friction in the pores. A loss of only 250 feet of head in 350 miles is relatively small, and indicates an open texture in the sandstone through which the water travels. Where it comes to the surface in the states named, it is composed of large round quartz grains, with much pore space. Chippings brought up in drilling wells at Cincinnati and Hamilton indicate that a part of the water-bearing stratum in this region is of similar character, though the formation embraces also other beds which are not of this character.

Since the water from the St. Peter sandstone has here an effective head of 600 feet, it would actually flow from the mouth of the well in the lower parts of Cincinnati where the altitude is about 540 feet.



A.—Gullied slope south of Bellevue, Ky. The limestone fragments indicate that erosion has reached the underlying rock.

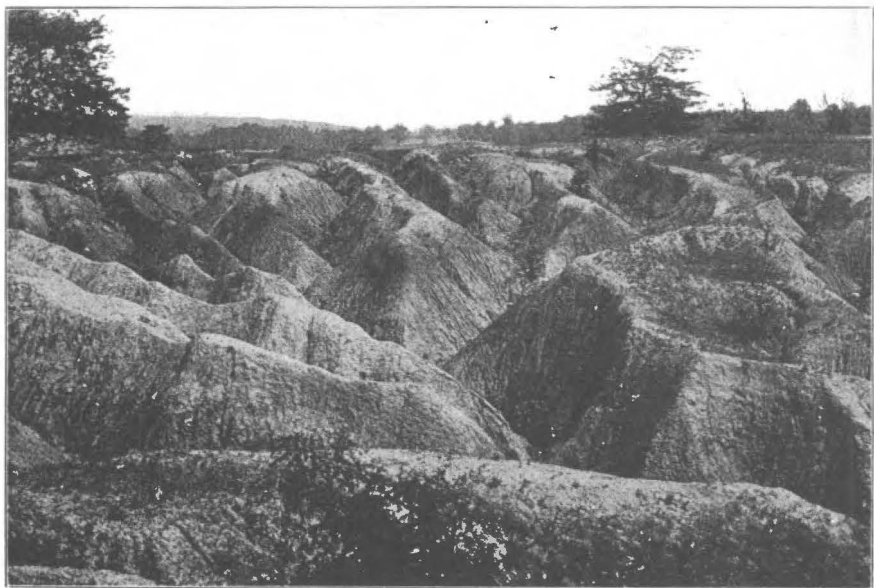

B.—Badlands eroded from the older glacial drift, west of Spring Grove Cemetery, Cincinnati. (Compare figures, pp. 86-88.)

## CHAPTER VIII

### MINERAL RESOURCES

#### BUILDING STONE

The most widespread mineral resource in this area is the limestone for building purposes. From Chapter III it is seen that beds of limestone form a part of every formation which outcrops in the area. Any of these which are thick enough may be used in walls, but most of the formations contain so many thin beds, or so much shale, or both, that the handling of such material would render quarrying unprofitable.

**Quarries in the Fairview Formation.**—Practically all the quarrying on a commercial scale is done in the Fairview formation (see p. 66), and most of it in its upper portion, the Fairmount member. In the upper fifty feet of this formation there is more limestone than shale, perhaps twice as much, while below that in the Mount Hope member the proportions are almost reversed. Throughout both members of the Fairview formation, a fair proportion of the limestone layers have a thickness of more than four inches, some being as much as seven inches thick, and an occasional one nine or even ten inches. In locating a quarry it is desirable to find as many thick beds as possible within a narrow vertical range so that the handling of discarded material will be as small as possible. Hence most of the quarries near Cincinnati, and the principal ones at Hamilton, are well up on the hillside in the Fairmount member. Just south of Coke Otto considerable quarrying has been done in the lower or Mount Hope member at the foot of the west bluff. The amount of discarded material here is so great as to make quarrying unprofitable except for local work.

**Character of the Stone.**—The limestone of this locality has the advantage of occurring in beds whose thicknesses continue fairly uniform for such short distances as the length of a quarry, though this is not true for long distances. The upper and lower faces of the blocks are therefore parallel and need no trimming. The other four faces must be trimmed, because the joints which divide the bed into natural blocks run very irregularly.

The color of the fresh limestone is a decided blue, but adjacent to the joints the surface of the block is in many cases colored brown

or yellow by oxidation (see p. 73). Generally this discoloration is superficial, and, therefore, does not show on the trimmed edge of the block. Where it is deep the block is not used in good walls.

**Uses.**—This stone is universally used for foundations in this community, except in some cases where ornamentation or variety is the chief consideration. It has also been used for a number of churches and other monumental buildings, such as the Art Institute in Cincinnati. (Pl. VII-B). With a little care in assorting blocks of different thickness, the blocks may be arranged in the wall in a pleasing pattern. The stone neither stains nor fades.

These advantages are sufficient to bring the stone into general use locally, but not to make of it an article of commerce outside the localities where it is quarried. For ornamental purposes and variety, a considerable amount of stone is imported, especially of the Dayton limestone and the Bedford limestone of Indiana.

#### ROAD METAL

Of the material discarded in quarrying, the shale has no value except for filling. The limestone is almost universally used in road making. The supply of such road material from the culls of quarries and from the grading of streets, etc., is very large, but in addition to this, some limestone is quarried for this express purpose. As a foundation for roads and streets it is highly satisfactory. It is also satisfactory as a surface material for macadam roads not subject to severe wear, but under heavy wear it rapidly passes into a fine dust which burdens the air and is harmful to man and beast as well as to vegetation. In cities it is intolerable except when oiled. On the other hand, when treated with a suitable grade of oil it makes a smooth, elastic, and enduring surface. It has the advantage of retaining the oil a longer time than a sandy surface does. A single treatment annually with a well chosen oil is sufficient to keep such a limestone surface in very good condition.

#### CLAYS

**Brick from Alluvial Clays.**—The manufacture of brick from local clays is an industry of importance because of the local demands of a large population. The quality of the product is entirely satisfactory for the uses to which it is put, but is not such as to cause a demand from outside the locality. Moreover, most of the clay used here is of a grade which is found very generally distributed over the United States. Much brick for "facing" walls and for ornamental purposes is shipped in from other localities.

The chief source of brick clay is alluvium from the flood plains of the larger streams. As explained on page 92, the mud of flood plains has settled from flood waters, and generally, therefore, occurs on top

of the sand and gravel. As the surface of the latter is apt to be somewhat uneven, due mainly to the wash of local currents in the flood waters, the mud which coats the plain may be much deeper at some places than at others. It is also finer, less gritty, and more plastic at some places, because the water from which it settled was more stagnant. All or nearly all of the *grit* was dropped from suspension before reaching these places of the best clay.

Owing to these differences of depth and quality, the selection of a spot for a brickyard on the flood plain is a matter of importance. Usually it is done by actually testing the clay. Most of the yards are located near Cincinnati and Hamilton. At Delhi, on the Ohio, the clay is found satisfactory to a depth of fifteen feet, though a test boring to fifty feet showed little sand, but most of the clay below fifteen feet is too sandy for brick making. The clay used at most yards averages much less than fifteen feet in thickness.

All of the brick made from alluvium near Cincinnati are made by a "wet mud process," that is, the clay is mixed with water before being put into the molds. The bricks must then be dried before being burned. All are common red brick, and are used largely on the inside of walls, though sometimes the best are selected out to be used for facing.

In the Miami Valley, just north of Hamilton, alluvial clay has been much used in the way here described, but in the only plant operating at present the "dry process" is used. In this process the clay is first thoroughly mixed without addition of water, and then pressed into molds. A higher grade of brick is thus produced.

At Milldale (or Latonia) brick of similar grade is being made on a large scale from the silts described on page 154 as composing the terraces along the Licking.

**Brick From the Surface Silt.**—A smaller number of plants are making brick from the surface silt. These plants are located on the uplands, mainly on the flatter uplands where the surface silt has the character of the "white clay" described on page 140. Most of the yards are located on the line of the Cincinnati, Lebanon & Northern Railroad between Rossmoyne and Brecon. At the latter place the white clay is six or seven feet deep with a few stones near the base. For brick making the topmost four or five feet of the underlying till is also used. The number of stones increases with depth. Beyond the depth of ten or eleven feet from the surface, the number of stones is too great. The brick made from this clay are similar in quality to those made from the alluvium.

**Shale Brick.**—A plant in the west bluff of Mill Creek Valley in Cincinnati, and another in the bluff at Newport, Ky., have been making brick by a dry press process from the Eden shale. The shale is finely ground in a crusher and then firmly pressed into molds, generally with no other moisture than that which it contains when taken from the bank.

The shale of the Eden group is of excellent quality for such use. It might well afford the basis of a large industry were it not for the interbedded limestone, and the popular preference at present for other styles of brick. The limestone has been successfully eliminated in the two plants mentioned. The thicker beds have been sold for building purposes, and the fragments from the thinner beds have been eliminated in the crushing process.

The brick thus made from shale is of high grade, having ample strength and a beautiful red color. It is used exclusively for facing. Styles come and go in brick as well as in clothing, and unfortunately for the shale brick industry in recent years, red pressed brick have not led the style. When they come into popular favor again it may be expected that the Eden shale will be more largely used.

**Cupola Lining.**—On the upland northeast of Delhi the surface silt is locally a dense clay rather than a silt. From several extensive pits this clay has long been dug and sold to foundries for lining cupolas. Although it is not commonly thought necessary to use a very particular grade of clay for this purpose, the clay from these pits has enjoyed great favor, and has sometimes been shipped to neighboring states. It is locally spoken of as *fire clay*, but chemical analysis shows that it does not differ much in constitution from the same formation elsewhere. The iron, lime, magnesia, and alkalies of clays constitute *fluxes*, that is, they make the clay soften at lower temperatures. The amount of such flux in this clay is too large for a fire clay.

#### BUILDERS' SAND AND GRAVEL

Sand and gravel for structural purposes is widely distributed in this region, as might be expected where a great ice sheet came to an end by melting. Deposits are found in all the formations shown on the map as composed in whole or part of material laid down by glacial waters, and in addition to these, from the recent alluvium. These formations furnish material of all grades of coarseness, large cobble stones for paving, smaller pebbles for roofing, ballast, and concrete, and sand for mortar and cement.

**From Deposits of the Illinoian Glacial Stage.**—The oldest formation of this nature is the Illinoian outwash interbedded with till of the same epoch. It will be recalled that where these gravels are exposed at the edges of the Illinoian terrace, they are in large part consolidated to conglomerate. On this account, and because gravel is so much more available in other deposits, that of this age is not much used. The bank north of Coney Island (see p. 134), and some small private banks or pits are in this formation. The large excavation by the Pennsylvania Railroad in the knoll one mile north of Milford, has been made to obtain filling. For this purpose gravel, sand, and bowlder clay have been taken without discrimination.

The sand from this formation is likewise less used than that of later epochs. In general it seems to be less "sharp" and, therefore, less valuable for building purposes. One large bank in this formation, described on page 134, is in the east bluff of the Little Miami on the road to California and Mount Washington.

**From Deposits of the Wisconsin Glacial Stage.**—The great resource of sand and gravel is found in the terrace remnants of the valley trains of the Wisconsin stage. Probably not many localities in Ohio or adjacent states would compare in this respect with the Miami and Little Miami valleys. In the former, the Big Four Railroad owns a large area of terrace land at Valley Junction, and the Chesapeake & Ohio owns a similar area at Valley View. Both railroads operate large pits and ship the gravel for ballast to neighboring states. The Norfolk & Western Railway owns a large area in the Little Miami Valley south of Terrace Park, though a part of this is on terraces a little lower and younger than those of the Wisconsin stage. There are also large gravel pits at Loveland and Terrace Park.

Many large sand and gravel pits in this formation are owned and operated by companies which supply structural materials to Cincinnati and other cities. Some of these have installed crushers, washers, and screens for assorting the material. Such pits are distributed along the Little Miami from Loveland to Linwood (Cincinnati). Large operations of the same kind are carried on at Bellevue, Ky., at Sedamsville (Cincinnati), at Bond Hill (Cincinnati), and along the Miami between Miamitown and New Baltimore. Harrison, just west of this area, has very large deposits of gravel of this age which are being to some extent worked.

The kames of the same age at Camp Hageman contain a vast amount of good sand and gravel. One large pit has been opened and thoroughly equipped and is now shipping extensively to Cincinnati and other cities. Gravel has also been taken at various times from the kames south of Hamilton.

**From Recent Alluvium.**—Of operations in terraces younger and lower than the Wisconsin outwash, the most extensive is east of Trenton, near Miami River. The stones of the gravel here are rarely larger than two or three inches and a large amount of sand is obtained.

Sand for building purposes is also pumped from the bed of Ohio River and Mill Creek. Excellent sharp sand is thus obtained. At places pumping may be carried on year after year, the supply being replenished during floods.

#### MOLDERS' SAND

**Characteristics of Molders' Sand.**—The process of casting iron is essentially this: a "pattern" of the same size and shape as the iron



casting to be made is embedded in sand closely packed. By a device not necessary to explain in detail, the upper half of the sand is lifted off and the pattern is removed. The upper half is then replaced on the lower, thus leaving a hollow interior, into which the melted metal is poured.

The sand for this purpose must be carefully chosen. Its essential quality is a tendency to pack and retain its form despite considerable jar. This must be accomplished with the sand almost (but not quite) dry, otherwise steam would form when the metal is poured in and the mold would be shattered. A small amount of moisture and therefore of steam is inevitable. An admixture of adhesive substance like clay would cause the sand to hold its shape, but if it filled the pores and prevented the escape of steam, the mold would still be shattered.

The characteristics of a molding sand, by virtue of which it packs and holds its shape and does not "blow" when the metal is poured in, are as follows: The grains should be angular. This causes them to interlock and thus to move over one another with difficulty. They should be of different size. The smaller ones occupy the pores between the larger. In this way the structure is made denser and stronger. A third feature is some kind of "bond" causing the grains to adhere slightly. If clay be present in sufficient amount to do this, it is apt to clog the pores, causing the mold to explode or "blow" when the metal is poured in, and the moisture is converted into steam. Much molders' sand, especially of the coarser grades, has a small amount of iron oxide coating the grains and causing some adhesion. The amount required does not seriously clog the pores and it is very efficient as a bond.

**Sand From the Loess.**—The finer grades of molders' sand are obtained from the loess. It is dug out in large quantities from the bluffs back of Covington, Newport, and Bellevue, Ky., likewise from a large deposit twenty or more feet deep at the foot of the bluff back of Delhi. The topmost two or three feet are discarded because weathered in part to clay. Of the loess beneath that, some is not suited to use as molding sand. That which is so used is still further classified as to coarseness. The loess is used in making relatively small castings. It is shipped not only throughout Ohio, Indiana, and Kentucky, but frequently to more remote states.

Loess is also used in other ways; sometimes to give body to dynamite; sometimes to serve a similar purpose in commercial fertilizers.

**Sand Beneath the Surface Silt.**—Coarser grades of molders' sand are obtained at various places on the uplands near Cincinnati, just beneath the surface silt. One such deposit near Cold Spring, Ky., is about fifteen feet thick. It is a quartz sand containing a small amount of iron oxide as bond. Similar deposits are being worked on the upland northeast of Delhi and east of North Bend. The last named deposit

is associated with much gravel, five-sixths of whose pebbles are of chert and quartzite, the remainder being vein quartz and various igneous rocks.

**Sand From the Wisconsin Outwash.**—Another source of molders' sand is the glacial outwash of Wisconsin age. Whole fields near Overpeck, north of Hamilton, are found underlain by such sand. It is found just beneath the soil in a bed rarely exceeding three feet in depth. Beneath this is clean sand suitable for building purposes. Some thousands of tons of this molders' sand have been shipped away in past years. Many acres have thus been stripped. The land after stripping is again farmed. A deposit, in every way similar to this, was worked for many years just south of Schenck's Station, on the C. H. & D. Railway.

Deposits of this character show something of the origin of these coarser grades of molders' sand. They differ in no important respect from the clean sharp builders' sand beneath, except in the matter of the iron oxide which makes the bond. Wash this out and the sand which remains is indistinguishable from that which lies beneath. It is plain that the sand as originally washed out from the glacier and deposited, was common sharp sand like the deeper beds at present. Being of glacial origin a part of its grains were of the dark minerals containing iron. These decayed, giving rise to iron oxide. At the same time some of the clay from the soil above was washed down into the sand. Thus the molders' sand has progressively thickened at the expense of the clean sand below. The process is too slow to be of economic importance in historic time.

## SOILS

### *Soils in General*

**Surface and Subsoil Distinguished.**—Soil is the surface portion of the mantle rock which is directly concerned in the support of vegetation. Generally a distinction is made between top soil and subsoil. The former, generally less than a foot in thickness, is commonly (though not always) darker and of finer grain. The contrast may not be sharp, and generally no exact plane of separation can be pointed out, but in many areas the distinction is sufficiently sharp so that the plowing up of an additional inch or two inches changes the character of the surface soil very decidedly for better or worse.

**Constituents of Soils.**—The darkness of the top soil is due in part to the more complete oxidation of iron (see p. 124), and in large part to decomposing or decomposed vegetation called *humus*. This is one of the essential constituents of soils. Within the limits of ordinary agricultural soils, the more humus the better. It is always in danger of being too much reduced. In nature, without man, each generation

of vegetation dies down and forms humus for later generations. When crops are cut and removed this order of nature is disturbed and the soil must be artificially fertilized.

It is not to be understood that humus is the only constituent of soils which is liable to depletion, or that fertilizers are added simply to restore this. There are many things in soils which are necessary to plant life, but most of them are sufficiently abundant so that their need is rarely felt. The three things most liable to depletion are nitrates (usually contained in humus), potash, and phosphate. Since these must so frequently be added, they are commonly regarded as the elements of fertility.

In recent years much has been learned concerning the importance of the physical condition of soils. Fertility is now known to be quite as dependent on physical condition as on chemical composition. Both are indispensable.

**Functions of Subsoil.**—While chemical compounds (plant food) are contributed to crops chiefly by the surface soil, they are derived



Fig. 56.—Section of an unglaciated hilly country showing gradual transition from solid rock to soil. (Salisbury and Atwood.)

in part also from the subsoil, being carried up in solution by ground water which rises from the water table by capillary attraction. It is one of the functions of the subsoil, therefore, to contribute food to the growing plant, but the most important function of the subsoil lies in its relation to the water itself. It must allow it to pass downward when there is too much at the surface, and must lift it again by capillarity when the surface is too dry. A subsoil which is right for hills in which the water table is deep would not be right for a broad flat bottom land where the water table is near the surface. If the broad bottom lands of the Miami Valley had a dense clay subsoil instead of the sand and gravel which they have, the surface would remain wet and the soil unworkable a long time after heavy rains; but if their porous subsoil were transferred to the hilltops, the water table would sink so low that crops could not survive a drought.

**Soils Classified as to Origin.**—Soils are either residual or transported. Residual soils are formed by the decay of the underlying rock. Hence they are also called soils *formed in place*. In a good section all gradations may be seen between the solid rock below and the fine soil above. (See Fig. 56). Those formed by the decay of limestone and calcareous shale (as in the Blue Grass region) are almost always fertile; those on

non-calcareous shales less so, and those on sandstone barren unless other elements have in some way been mixed in. Many uplands in eastern Ohio and Kentucky have soils made from sandstone. Igneous rocks may yield either good or poor soils. Those with the largest proportions of quartz (generally light colored rocks) are least apt to produce good soils. The darker rocks contain more decomposable minerals and yield more clay, making better soils both chemically and physically.

Transported soils may be laid down by water, wind, or ice. All three kinds, as well as residual soils, are represented in this area. All

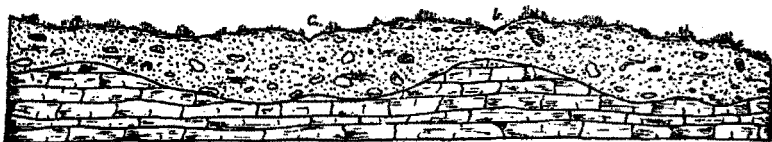

Fig. 57.—Section of a glaciated hilly country showing abrupt transition from solid rock to glacial drift from which the soil is derived. (Salisbury and Atwood.)

transported soils have this in common: they are made of materials gathered from many localities; hence they are apt to be heterogenous in character. The chances of being fertile are thus greatly increased, though not all transported soils are fertile.

It will readily be seen that on steep slopes the mere process of "creeping" (p. 76) plays a large part in mixing soils. Especially is this true where the rocks at different levels are of different kinds. In such cases it is no longer true that each kind of rock is overlain



Fig. 58.—The same, where glacial drift is so thick as to obscure the pre-glacial valleys. (Salisbury and Atwood.)

merely by its own products of decay. The soil near the base of the slope may be a mixture of the soils formed on various kinds of rock. Such are not transported soils in the sense of water-laid, wind-laid, or ice-laid sediments. They are known as *colluvial* soils. It is not necessary to distinguish them from residual soils in this area.

### *Soils of This Region*

The soils of this region may be classified according to their derivations from the following formations: (1) the bed rock (residual soil), (2) the surface silt and loess (soils due to wind transportation), (3) the

bowlder clay of the Wisconsin stage (soils due to ice transportation), and (4) the alluvium (soils due to water transportation).

**Residual Soils.**—Where the Pleistocene formations named are absent, the soil is formed by the decomposition of the limestones and shales. Such soils are, therefore, in the main, limited to the steeper slopes where the Pleistocene formations either failed to come to rest or have been subsequently washed away. Residual soils are found locally on the bluffs of the Ohio, Miami, and other great valleys and on the sides of the steep valleys by which these bluffs are at places dissected. These are the places where the bowlder clay and surface silt, if ever deposited, have been largely washed away. It may readily be inferred that the soil on such slopes is thin, for it tends constantly to wash down. This is especially true since the cutting away of the forests from much of this hilly land. Except for their thinness, these soils are fertile and enduring. They are of the same general character as the soils of the famous Blue Grass region of Kentucky. Their color is dark yellow or ruddy, and they may be further darkened by decaying vegetation. At many places they contain slabs of limestone derived either from close at hand or by "creep" from the higher slopes. Wherever these residual soils have sufficient depth they are well adapted to general farming.

**Surface Silt and Loess Soils.**—The mantle of silt or silty clay, which covers practically all of the older till sheet, is the most important soil maker in the southern half of the area. The till of Illinoian age has no importance in this respect, being almost entirely covered. This silt sheet derives its colloquial name "white clay" (used from Illinois to Ohio) from the soil which it produces on nearly flat uplands where the subsoil is not well drained and aerated. Under these circumstances the color of the surface soil is a pale yellowish or gray. A common characteristic of such tracts is a large number of holes and mounds of the common crayfish. Hence the common term "crawfish lands" in southern Indiana and Ohio generally applies to uplands whose soil is derived from the surface silt. The term "slash lands," used in Indiana, designates the same thing. Where humus is abundant the color of the soil becomes a darker gray or even brown. It is generally mellow and free from clods where drainage is fair and humus not deficient. Such is generally the case within this area. Where it covers broad flat uplands, as in some counties of southern Indiana and Ohio, the drainage is poor, and humus generally deficient. The soil is then very light in color and intractable. If plowed too wet it forms clods like sun-dried bricks. So far as this area is concerned the soil on the surface silt may be called a "silt loam."\* It is fair for general crops and generally good for wheat; likewise for fruits.

\*Loam is a mixture of clay and sand, or intermediate between them. The terms clay loam, sandy loam, silt loam, medium loam, etc., explain themselves.

PLATE XII.

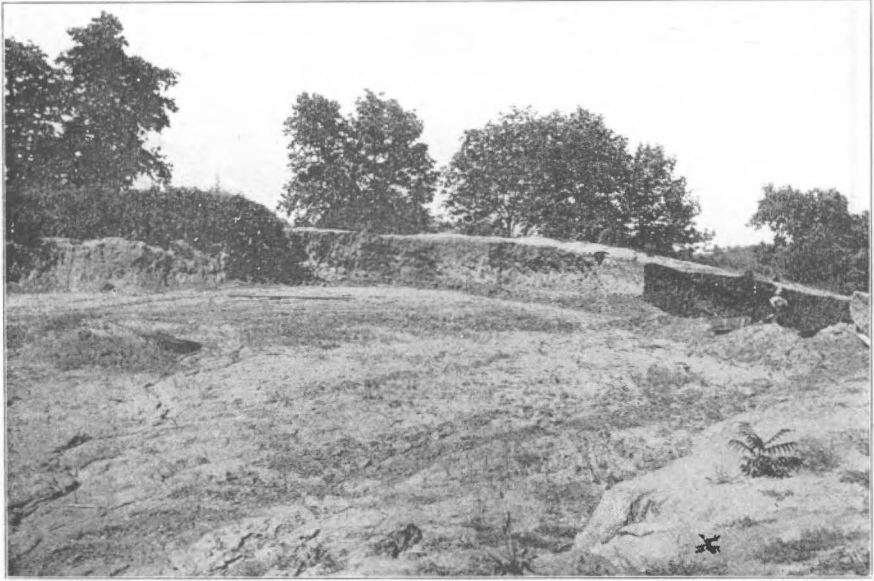

A.—Loess being stripped from hilltop at Bellevue, Ky., for molders' sand. (See p. 182.)

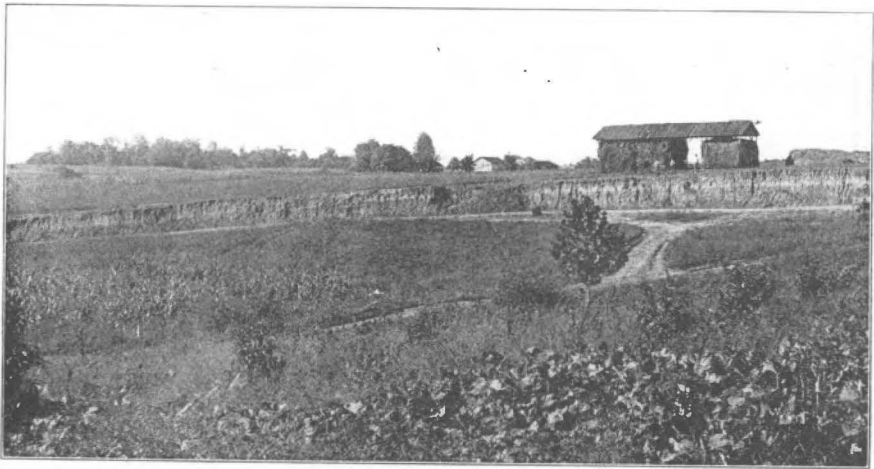

B.—The surface silt being stripped from uplands near Delhi, O., to be used for cupola lining. (See p. 180.)

A highly important soil due to wind transportation is represented in this area by that which is formed on the true loess on the southern bluffs of the Ohio. It is a mealy loam of excellent physical properties. In this area it covers only a narrow strip of hills. Where it covers broad areas, as in Iowa, Missouri, Illinois, and eastern Nebraska, it forms the basis of one of the chief agricultural soils of the United States.

**Soils on the Boulder Clay.**—The soil formed on the younger till sheet is in general a medium loam, locally a sandy loam. This character is determined by the composition of the till described on page 146. Being derived from a formation which is itself derived chiefly from the underlying limestone and shale, it is not unlike the residual soil in ultimate constitution. Over most of the area, stones are rare in the topmost two or three feet of the younger till and hence in the soil. At places, however, this stoneless zone is absent, and spots of gravelly or stony soil appear. In contrast with the gray color of the soil on the surface silt to the south, this soil has a yellowish color, with here and there brown or even black patches. These give a clouded appearance to the surface in almost any wide outlook over plowed fields.

Another contrast between this soil and that farther south is in the matter of destructive washing. Gullies are not unknown on the Wisconsin till. In a few places the washing of the soil is serious. But there is nothing like the wholesale wasting of soils by gullying which is witnessed on the older formations. (See Pl. XI-B.)

In general fertility this soil is decidedly superior to that found farther south on the older Pleistocene formations. Farmers on both sides of the border line speak familiarly of this contrast. A line traced between the better soils on the north and the poorer soils on the south by the sole criterion of reputation for fertility, would nowhere deviate more than a mile or two from the edge of the younger drift sheet. This reputation is reflected in the prices paid for land. A difference of twenty-five to fifty per cent in favor of the till soils to the north is not uncommon. Mason, on the relatively flat uplands covered by the younger drift, is the center of a prosperous canning industry. With a similar topography, the vicinity of Hazelwood and Brecon is decidedly inferior as a farming section.

**Alluvial Soils.**—Probably the most fertile and highest priced farms in the area are found on the terraces and flood plains of the broad valleys. Many farms on these alluvial soils have been bought at \$150 to \$200 per acre. From the origin of alluvium (see p. 92) it is plain that soils formed upon it may have any texture, from gravel at one extreme, to dense gummy clay at the other. The broad valleys of this area have a very large proportion of medium loams. For practical purposes these alluvial soils must be divided into two classes those which are liable to flooding and those which are not. In general this corresponds to the division between flood plains and terraces

Under this head of alluvial terraces the broad terraces of the Illinoian glacial epoch in Mill Creek Valley and elsewhere are not included. These are not only formed in part of boulder clay, but covered with the surface silt which is the basis of their soils.

The largest areas of alluvial terrace are found in the Miami Valley. The most extensive tract is in the "Hickory Flats" stretching from Sevenmile to Trenton and south to Overpeck. This is one of the best farming districts in the Miami Valley, which is widely known for its beautiful farms. At the surface are a few feet of loam. The deeper subsoil is everywhere of sand and gravel. On account of the wide extent of nearly flat surface at a low level, the water table is sufficiently near the surface so that the soil is not unduly dried out despite the very porous nature of the subsoil. Similar soil conditions are found in parts of Mill Creek Valley and in the New Haven trough where the name "Hickory Flats" is likewise used.

Over considerable areas the flood plain soils are quite as fertile as these terrace soils. Venice is the center of such a section. It was generally believed to be above flood level, but it was submerged by the flood of March, 1913. As is the habit of floods on bottom lands, there were local currents which scoured channels in the fertile loam and cut deep into the gravels below. Locally such scour reached a depth of twenty feet. Elsewhere fields were buried by shoals of sand and gravel, sometimes to a depth of four or five feet. Such local disasters are very impressive, but they affect only a small fraction of the total area of alluvial soils. They should not be allowed to divert attention from the larger fact that where the flood moved slowly or rested quietly it was depositing fertile silt. In other words, it was engaged in the same process by which the fertile bottom lands were originally made. In this way, the resources of fertility for the future are stored up.



## CHAPTER IX

### HABITATION

#### THE LOCATION OF CINCINNATI

The early settlement of the "Miami Country" and its subsequent history and life are closely bound up with its physical geography. This makes a knowledge of the latter necessary to a proper understanding of the former.

**Order of Settlement in the Mississippi Valley.**—To a casual observer of the great low plain constituting the upper Mississippi Valley, there might seem to be little choice as to where settlement should begin. In a large way the country is homogeneous, being in this respect perhaps the most distinctively *American* portion of the United States. The great rivers offer the most obvious suggestion for a beginning. It may therefore seem strange at first that central Kentucky was permanently settled some fifteen years before a beginning was made on the banks of the Ohio, and this, despite the fact that many of the supplies of the Kentucky settlements were carried down the Ohio to Maysville, Ky., whence they were taken overland in wagons.

We are now so much accustomed to the motives of trade that it is hard to understand the motives for occupying a region which is accessible only by wilderness roads, while leagues of fertile country remained unoccupied beside a great natural highway like the Ohio. Yet for more than a decade there was a growing commerce on the Ohio to supply the wants of the Blue Grass settlements, with little or no settlement on the banks of the Ohio below Wheeling, even at the necessary landing place.

To understand this apparent anomaly it is first necessary to examine a good physical map of eastern United States. This shows that the great Appalachian Valley trends west as much as south. This brings it within 200 miles of the Kentucky Blue Grass region. (See Fig. 2, p. 21.) Even Pittsburgh is almost that far from the same valley in Pennsylvania, and separated from it by a country similar in topography to that which had to be crossed by the pioneers farther south.

A second consideration is found in the character of the settlers and their motives. The pioneers of Kentucky were primarily farmers; producers rather than traders, and, as such, were more concerned with

the fertility of the soil than with the means of access. The immediate banks of the Ohio are nowhere so good for farming as is north central Kentucky.

Another consideration was greater security from Indians. The Cumberland Plateau, which intervenes between the Great Valley and central Kentucky, was not much more attractive to the Indians than it has been to the whites; hence the wilderness roads which crossed it were relatively secure.

Finally it should be remembered that the north bank of the Ohio was embraced in the Northwest Territory, within which it was not the policy of the new nation to permit settlement. But this restriction did not apply to the south bank, and was not in force at all when the Kentucky settlements were made.

**Importance of Navigation of the Mississippi.** — The settlements in southwestern Ohio and central Kentucky had much closer relations with New Orleans than with any place in the thirteen colonies. This was to be expected in view of their direct connection by river. Although the return from New Orleans was made by land, and was not much easier than a land trip to Philadelphia, it should be remembered that they were concerned chiefly for their exports, pork, flour, and whiskey, which could be floated down stream in flatboats. From New Orleans these articles were reshipped to ports on both sides of the Atlantic. Articles purchased came largely from the eastern colonies by way of the Ohio.

The chief public question which agitated the new settlements was therefore the free navigation of the Mississippi. The government on the Atlantic seaboard seemed to them indifferent to their interests, or at least unnecessarily slow in action; hence relations were for a time very much strained. Free navigation of the river was at length guaranteed by treaty with Spain in 1795, though not fully realized until after the Louisiana purchase in 1803.

**Resources Advertised by John Cleves Symmes.** — After John Cleves Symmes had become the proprietor of more than half a million acres in this region, he advertised in 1788 the following: "Excellent soil and climate, absence of mountains, level country, stone quarries, never-failing springs, rivulets and mill streams." His emphasis on the topography is noteworthy. How this appealed to the settler may be understood by comparing the topography of this region with what he saw on the long journey from the great Appalachian Valley. That valley itself is ribbed with mountain ridges between which many of the cultivable strips are narrow. On its northwest side rises the Allegheny or Cumberland escarpment, 1,000 or more feet in height, and forming the eastern edge of a plateau, so deeply cut by streams that it is always spoken of by the people as the *Allegheny Mountains* (in the north) or the *Cumberland Mountains* (in the south). The height

of this plateau and the depth of its valleys decrease toward the northwest, but not until the Blue Grass region is reached in Kentucky, or the glaciated plains in western Ohio, is there any large area to invite the farmer.

In the matter of soils a similar comparison may be made between that which was passed on the way and that which was found by the pioneer in this region. The plateau to the east has a large proportion of sandstone and relatively little limestone, hence the soils are inferior. The soils of the Miami country have been described above.

The preceding chapters make it clear that all the items in Symmes' advertisement were justified. It will be observed that he omitted all mention of forests. Yet two of the leading industries in the development were directly due to forests. In the early days the mast (acorns, etc.) made it possible to raise hogs at small expense. The city thus developed almost immediately the pork-packing industry, in which later, for many years, she led the United States. The hardwood forests with their abundance of hickory also formed the basis of her great carriage manufacturing, which is still important.

At the time of the first settlement, the coal resources of the Allegheny plateau were but little known. The nearest point of this field is distant about 100 miles from Cincinnati, but coal is so easily and cheaply sent down stream in barges that, in respect to this resource, Cincinnati has almost the same advantages as Pittsburgh.

**Factors Controlling the Location of Cincinnati.**—The Ohio has always been the most used stream in the United States. It has, in the first place, the greatest volume of all streams flowing east or west, unless it be the Columbia. It has also a low gradient, averaging less than nine inches per mile, and flows through a region of fairly dense population which produces much freight (coal, etc.), peculiarly adapted to water shipment. Until some time after the Civil War, the importance of the river as a means of transportation was very great. Since that time traffic by river has greatly decreased. At present it amounts to a small fraction of the railroad traffic at Cincinnati. The benefits of river traffic to Cincinnati at present are largely indirect, except for the great consideration of cheap coal. It is well known, however, that statesmen and students of transportation place much stress on the coming importance of internal waterways, and that the United States is in various ways making preparations for a revival of river traffic.

In any case, the presence of the Ohio River has, from the first, been one of the main reasons not only for the location of Cincinnati, but for its very existence.

The factor which determined the location of the city somewhat more exactly, is the meeting at this place of the Licking Valley from the south and Mill Creek Valley from the north. Near Hamilton

the latter merges with the wide Miami Valley, which gives an easy course for 100 miles to the north; but Mill Creek itself could scarcely be a factor even in canoe travel. Nevertheless this natural cross-road was followed by Indians from prehistoric times. By this route the tribes north of the Ohio made their raids on the Kentucky settlements. Later it became, in succession, the line of wagon travel, canal traffic, and finally the chief entrance for railroads into Cincinnati. Even before Cincinnati was settled, Matthias Denman bought the ground on which the business section now stands, intending to found

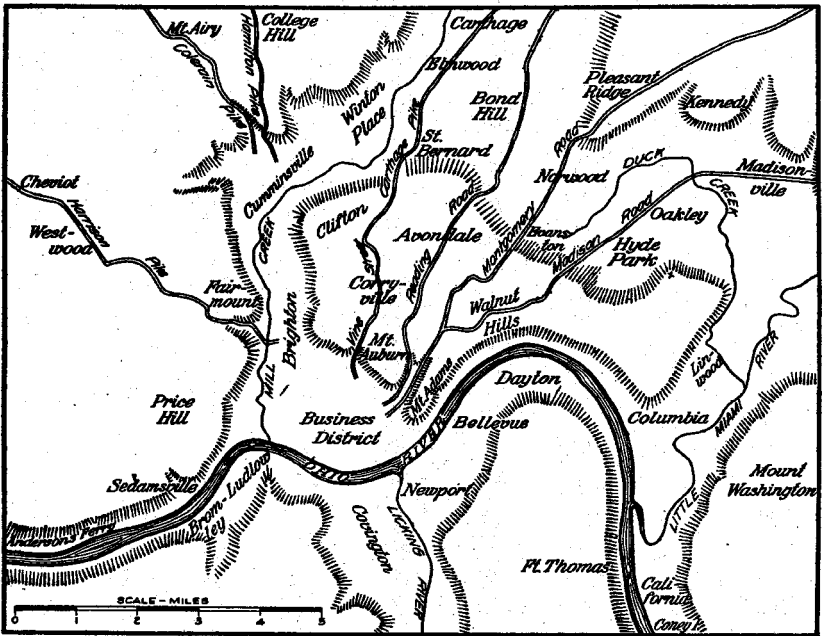

Fig. 59.—The site of Cincinnati.

a town and “establish a ferry.” Later, that ferry and others became enormously important. There is no other natural highway crossing the Ohio which compares in importance with that made by the Licking and Mill Creek valleys.

#### CHARACTER OF THE SITE AND ITS INFLUENCE

**Independent Communities.**—The actual site of Cincinnati was determined partly by the place of crossing the Ohio, and partly by the local divergence of the bluffs. This latter factor causes the Cincinnati basin with its several square miles of flat ground 110 feet above the river and 40 feet above the highest water. Settlement climbed upward from the river to this terrace somewhat gradually. That the city

should ever reach and climb the bluffs seems to have been an afterthought. Other settlements, however, grew up on the hilltops and throughout the Miami country. To reach these, the roads which radiated from Cincinnati climbed the bluffs through the notches made by small streams. Thus were determined Gilbert Avenue (Montgomery Road and Madison Road), Reading Road, Vine Street (Carthage Pike), Colerain and Harrison pikes, and several others. Other villages grew up along these roads, until within the present area of Cincinnati there were forty or fifty more or less independent villages, many of them having their own corporate organizations. Thus Clifton, Mount Auburn, Mount Adams, Walnut Hills, Price Hill, Westwood, and many others grew on the hilltops, and Cumminsville, Brighton, Carthage, Norwood, and others in the valleys (Fig. 59).

**Local Sentiment.**—Among the results of this peculiar mode of growth is the strong community consciousness which still attaches to the local centers. There are in Cincinnati forty or more local improvement or welfare associations. These are a very important factor in the life and government of the city. It is not to be understood that the organization of these associations dates back to the time of village independence, but the sentiment which, under later conditions, caused these societies to take shape was inherited from earlier conditions. Norwood (population 22,000) and St. Bernard (population 5,800) still remain independent cities, practically surrounded by Cincinnati.

**The Laying Out of Private Grounds.**—Another result of the peculiar topography is found in the extraordinary number of large and beautiful private grounds surrounding suburban homes. Above and beyond the cliffs there was no lack of room, but much of the area was dissected by ravines, making it difficult to construct streets, without which small lots could not be laid out. Even now, the city embraces much unimproved ground of this character. With increasing population new streets have been graded, and many of the old homesteads have been thus subdivided. The slope of the steep bluffs overlooking the city has almost prohibited road making, with the result that these have been but sparingly occupied by homes of a humbler sort.

**City Parks.**—The peculiar character of the city's parks has been determined by the same principles. Eden Park and Burnet Woods, and the University Campus, occupy areas of exceptionally deep and beautiful ravines (some of which have been leveled up at great expense to the city). The ultimate park plan involves the parking of the now unsightly bluffs, extending practically around the lower city except on the south. This is an opportunity almost unique among American cities. It involves a narrow strip of park with the maximum amount of outlook and good air, and located at the minimum distance from the centers of dense population.

**Building in the Basin.**—The flat portion of the city east of Mill

Creek (about three square miles) is still too large to be used exclusively for business. It is large enough to accommodate the business of a city several times the size of Cincinnati. The outer parts of this flat were long the suburbs and outlying districts. For a long time the canal along the line of 11th street was the practical limit of business. The outlying portion beyond was then called "Over the Rhine," a name which this district has ever since retained. This is now the most densely populated part of the city. There is no room for private yards except some small courts in the rear of dwellings and stores. Most of the area is occupied by buildings two to four stories high, the ground floor being used for stores and the upper floors for residence.

At the same time the business of the city is greatly congested within a small area nearer the river, having no natural boundaries. The streets are narrow, and the recent fashion of building tall buildings has added greatly to the crowding of these streets. Considering the narrowness of the streets on the one hand and the large level area which awaits a better class of buildings, the building of skyscrapers in Cincinnati seems peculiarly out of place. If covered with good buildings from six to ten stories high the area of the Cincinnati basin is sufficient to accommodate the business of the city for several, perhaps many, generations to come. The limiting of buildings to a moderate height will have a double advantage. Local congestion will be prevented and a larger area will be improved.

As noted in the description of the topography, the main portion of the city is completely encircled by a ring of low ground, the Ohio, Little Miami, and Mill Creek valleys and the Norwood trough. Manufacturing tends more and more to occupy this low strip. The railroads are necessarily there also. The lower part of Mill Creek Valley, in part occupied by railroads and factories, and in part waste ground, affords a natural site for a great harbor.

# INDEX

	Page.
Aggrading streams.....	81
Algae.....	43
Allegheny plateau.....	20
Alluvial clay brick.....	178
fans.....	82
slope.....	82
soils.....	187
terraces.....	93
Alluviation.....	92
Alluvium, recent deposits.....	181
Alternation of sediment.....	48
Andersons Ferry.....	25, 26, 65
cut-off.....	121
narrows of.....	116
Area covered by bulletin.....	19, 20
Arnheim shale.....	70
Artesian wells.....	172
Banklick Creek.....	29, 110
Basal conglomerate defined.....	45
Basal limestone.....	66
Batavia Junction.....	40
Batavia Junction drift section.....	132
Bed defined.....	51
Bedding planes, defined.....	51
Bed rock gradation.....	55
impurities.....	55
structure.....	55
formations of.....	56
how made.....	36
of the area.....	55
thickness of.....	56
variations of.....	56
Behavior of ice, Miami Valley.....	135
Behavior of ice sheet.....	126
Bellevue limestone.....	68
Black mica.....	37
Blue Banks.....	91
Bluffs of Miami River.....	31
Bluffs of Ohio River trough.....	24
Bowlder clay, soils on.....	187
Branching of valleys.....	87
Brick from alluvial clays.....	178
shale.....	179
surface silt.....	179
Building.....	193
Building stone.....	177

	Page.
Calcareous cement.....	39
Calcite.....	39
California.....	26, 28, 29, 114
Carbonate of lime.....	39
Carbonation.....	74
Carthage, sections of drift near.....	129
Caves, how formed.....	72
Cedar Cliff.....	91
Cement, calcareous.....	39
iron oxide.....	40
siliceous.....	40
Cementation of sandstone and conglomerate.....	39
Changes in form and position of curves.....	90
Channel control and floods.....	169
Character of stone.....	177
Chemical changes.....	73
Cincinnati anticline.....	60
basin.....	25
character of the site and its influence.....	192
factors controlling location of.....	191
location of.....	189
site of.....	192
terrace, section of pebbles.....	153
waterworks.....	29
Clastic rocks.....	37, 46
Clay.....	37
Clay and shale, history of.....	37, 40
Clays, alluvial.....	178
for ceramic wares.....	178
for cupola lining.....	180
Cold.....	74
Colluvial soils.....	185
Color.....	47, 48
Column defined.....	53
Communities, independent.....	193
Composition of the Miami River water.....	165
Composition of the Ohio River water.....	164
Conglomerate, basal.....	45
cementation of.....	39
origin of.....	37
testimony of.....	45
Consequent streams.....	84
Contact of older and newer drifts.....	147
Continental shelf.....	43
Corrasion.....	80
lateral.....	81
vertical.....	81
Corryville shale.....	69
Covington, Ky.....	25
Creep of rocks.....	76
Crevasses, movement of.....	102
Cross-bedding.....	47, 48
Cross sections of valleys.....	88



	Page.
Cumminsville glacial lobe.....	131
Cupola lining clays.....	180
Curves, changes in form of.....	90
Curves, changes in position.....	90
Cut-off at Andersons Ferry.....	121
Cycles of erosion.....	99, 100
Cynthiana formation.....	59, 60
Dalmanella multisepta.....	66
Dayton, Ky.....	26, 61
Decomposition of rocks.....	71
Degrading streams.....	81
Deltas.....	82
Dendritic valleys.....	88
Deposition from suspension.....	83
in shallow water.....	58
of sediment.....	81
on bottom of channel.....	83
Deposits during flood subsidence.....	83
from recent alluvium.....	181
of glacial stage.....	180
of Illinoian glacial stage.....	180
of Wisconsin glacial stage.....	181
terminal.....	82
Dicks Creek.....	84
Dimensions of Little Miami trough.....	29, 30
Dimensions of Miami River trough.....	30
Dimensions of Ohio River trough.....	24
Dips.....	61
Disintegrated rock.....	41
Disintegration of rocks.....	71
Dissection of land.....	96
Distribution of land and water.....	44
Down-cutting of valleys.....	85
Drainage changes.....	120
of area.....	24
preglacial.....	113
Drift and loess relation of.....	140
Drift section near Batavia Junction.....	132
near Carthage.....	129
near Hartwell.....	130
near Milford.....	133
Drift, southern limit of.....	125
topographic effect of Illinoian.....	125
Wisconsin, thickness of.....	145
Wisconsin, topography of.....	145
Dry Creek, Ky.....	26, 65
Dry Fork, changes in.....	123
Dry Fork of Whitewater.....	35
Duck Creek.....	32, 33
Dunes.....	161
Dune sand.....	38

	Page.
East Cincinnati quadrangle.....	19
East Fork of Little Miami.....	29, 30
Eden group.....	61
Park.....	61
shale.....	46, 61, 64, 65
shales as a source of water.....	174
Entrenched meanders.....	99
Epicontinental seas.....	57
Epoch defined.....	52
recent.....	159
Erosion.....	112
defined.....	76
of older and newer drifts.....	136
Fairmount limestone.....	66
Fairview formation.....	66
exposures.....	67
geographic relations.....	66
quarries of.....	177
thickness of.....	66
topographic relations.....	67
Falls.....	65
Feldspar.....	37, 41
Fire clay.....	180
Fivemile Creek.....	29
Flood Plain slopes.....	93
Flood problems.....	167
Flood subsidence deposits.....	83
Floods and channel control.....	169
Floods, cause of.....	166
in the Miami.....	166
in the Ohio.....	166
Flood plain making.....	92
Forest beds.....	148
Formation defined.....	51
Formations of bed rocks.....	56
Formations, table of.....	59
Formation, Whitewater.....	70
Fossils and their use.....	49
as labels.....	51
defined.....	49
in limestone, origin of.....	43
Fourmile Creek.....	26
narrows.....	156
valley.....	35, 115
Frost, work of.....	74
Functions of subsil.....	184
Geologic maps, function of.....	54
Geologic relations.....	21
Glacial deposits.....	106

	Page.
Glacial drift, local character of .....	107
erosion .....	105
lakes .....	156
load .....	105
lobe in Mill Creek Valley .....	128
lobe in Ohio Valley .....	134
outwash .....	110
outwash, character of .....	149
outwash of different ages .....	148
outwash of Wisconsin .....	148
stage deposits .....	180
Glaciation, older .....	124, 127
Glacier ice .....	101
Glaciers, classification of .....	101
work of .....	101
Gradation among sedimentary rocks .....	46
Gradation of bed rocks .....	55
Gradient of the Ohio River .....	26
Grading by streams .....	95
Granite .....	37
Gravel .....	39
Gravel and sand for building purposes .....	180
Ground moraine .....	106
Ground moraine, topography of .....	108
Group defined .....	52
Grouping of sedimentary rocks .....	51
Habitation of area .....	189
Hamilton quadrangle .....	19
Hamilton, section of drift at .....	147
Hartwell, sections of drift near .....	130
Headward growth of valleys .....	86
Heat .....	74
Hill Quarry beds .....	65
History of limestone .....	42
History of present surface .....	112
Humus .....	183
Ice sheets, behavior of .....	102
former .....	102
lobes of .....	105
movement of .....	104
thickness of .....	104
Igneous rocks, defined .....	36
Illinoian glacial stage .....	119
glacial stage deposits .....	180
glacier topography left by .....	135
ice sheet, behavior of .....	126
till .....	124
Impurities of bed rocks .....	55
Independent communities .....	193

	Page.
Indian Creek valley.....	35
Interior Low plateau.....	20
Iron oxide cement.....	40
Kame areas.....	155
Kames defined.....	155
Kaolin.....	41
Lake deposits.....	110
Lakes.....	156
Land and water, distribution of.....	44
Landslides defined.....	77
Lateral accretion.....	92
Latonia shale.....	63
exposures.....	64
geographic relations.....	64
thickness.....	64
topographic relations.....	64
Lawrenceburg, Ind.....	26, 30, 116
Levees.....	93
Liberty limestone.....	70
Licking River.....	25, 26
preglacial drainage of.....	114
trough.....	29
Lime, source of.....	42
Limestone.....	37, 55, 60, 63
basal.....	66
Bellevue.....	68
Fairmount.....	66
fossils in.....	43
history of.....	42
Liberty.....	70
structural features.....	48
testimony of.....	46
Little Miami changes.....	120
East Fork of.....	29, 30
glacial lobe.....	132
narrows of.....	117
preglacial drainage.....	114
River, bluffs of.....	30
River trough.....	29
River, valley floor of.....	30
terraces.....	93
Valley.....	105
Valley train.....	150
Little Muddy Creek.....	34
Loess and drift, relation of.....	140
Loess defined.....	137
distribution of.....	138
origin of.....	138
sand.....	182

	Page
Loess, soils .....	186
stage .....	187
Ludlow, Ky .....	26, 28, 115
Mantle rock defined .....	36
Marine shells .....	42
Marl .....	43
Mason quadrangle .....	19
Maysville and Richmond groups as sources of water .....	174
Maysville group .....	65
McMillan formation .....	68
Meander curves .....	83
Meandering streams .....	89
Mechanical changes .....	74
Member defined .....	51
Miami River .....	80
bluffs of .....	31
changes in .....	122
floods .....	166
navigation of .....	164
preglacial drainage of .....	114
source of sand .....	39
trough .....	30
valley floor of .....	31
water, composition of .....	165
Miami terraces .....	93
Miami Valley .....	105
behavior of ice .....	135
train .....	150
Mica black .....	37
Milford .....	29, 30, 91
Milford drift section .....	133
Mill Creek .....	25 30, 32, 110
Mill Creek Valley .....	32, 65, 105, 114
Cumminsville branch lobe .....	131
glacial lobe .....	128
train .....	151
Mill Creek, West Fork .....	33
Mineral matter in solution .....	77
Mineral resources .....	177
Molder's sand .....	181
Moraine, ground .....	106
Mt. Auburn concretionary shale .....	69
Mount Hope shale .....	66
Movements of ocean floor .....	58
Mud and sand distinguished .....	41
Mud boils .....	78
Mud, deposition of .....	41
Narrows at Andersons Ferry .....	116
Narrows, Fourmile Creek .....	156

	Page.
Narrows of the Little Miami .....	117
Navigation .....	163
influence on Cincinnati .....	190
of the Miami .....	164
of the Ohio .....	163
Nèvé defined .....	101
New Baltimore .....	31, 33, 91, 114, 115
New Haven trough .....	32
New Palestine .....	24, 26, 61
Newport, Ky .....	25
New Richmond .....	62
North Bend .....	26, 116
Norwood .....	32, 33, 34
glacial lobe .....	131
trough .....	32, 114
Nunataks defined .....	106
Ohio River floods .....	166
gradient of .....	26
navigation of .....	163
preglacial drainage of .....	114
source of sand .....	39
trough .....	24
valley floor of .....	26
water, composition of .....	164
Ohio terraces .....	93
Ohio Valley glacial lobe .....	134
train .....	153
Older and newer drift erosion .....	136
Ooze .....	43
Outwash deposits .....	110
Outwash of different ages .....	148
Overlap, a type of unconformity .....	53
Oxidation .....	73
Oxide of iron .....	40
Paddy's Run .....	33
Paddy's Run valley .....	35
Parks .....	193
Peneplain, age of .....	112
defined .....	97
making of .....	112
Percolation, increase of .....	167
Period defined .....	52
Petrifaction .....	50
Physiographic provinces .....	20
Plain and plateau distinguished .....	23
Plains, till .....	20
Planation by streams .....	90
Plants .....	75
Plateau Allegheny .....	20

	Page.
Plateau and plain distinguished.....	23
Plateau, Interior Low.....	20
Pt. Pleasant.....	61
Post-loessian stage.....	142
Preglacial drainage.....	113
how known.....	116
of Licking.....	114
of Little Miami.....	114
of Miami.....	113
of Ohio.....	114
of Todds Fork.....	114
Preglacial outwash.....	120
valleys, character of.....	118
valleys, slope of bed rock surface.....	118
Private grounds.....	193
Quadrangles.....	19
Quarries of Fairview formation.....	177
Quartz.....	37
Rapids.....	65
Recent alluvium deposits.....	181
changes in great valleys.....	160
drainage.....	159
epoch.....	159
Records of sedimentation.....	44
Rejuvenated streams.....	99
Reservoirs and floods.....	168
Residual soils.....	186
Resources.....	190
Revived streams.....	159
Richmond group.....	69
Richmond group as source of water.....	174
Ripple-marks.....	47, 48
Road metal.....	178
Rock, disintegrated.....	41
Rock, sedimentary, gradation of.....	46
Rocks, clastic.....	37, 46
igneous.....	36
subaerial.....	47
St. Bernard.....	32, 33
St. Peters sandstone as a source of water.....	175
Sand.....	37, 38
Sand and gravel for building purposes.....	180
Sand and mud distinguished.....	41
Sand beneath surface silt.....	182
Sand-boils.....	78
Sand for molding.....	181
Sand from loess.....	182

	Page.
Sand from Wisconsin outwash.....	183
Sandstone.....	55
cementation of.....	39
origin of.....	37
structural features.....	47
testimony of.....	45
Sangamon interglacial stage.....	135
Sapping of rocks.....	74
Scouring of channels.....	80
Section of drift at Hamilton.....	147
Section of pebbles in Cincinnati terrace.....	153
Sediment, arrangement of.....	45
carried in various streams.....	78
testimony of.....	45
Sedimentary rocks, gradation among.....	46
grouping of.....	51
origin of.....	36
Sedimentation records.....	44
Sediments, alternation of.....	48
source of.....	36
where deposited.....	36
Sediments of area deposited in shallow water.....	58
Series defined.....	52
Settlement, order of.....	189
Sevenmile Creek valley.....	35, 115
Shale.....	55
Shale and clay, history of.....	41
Shale, Arnheim.....	70
brick.....	179
Corryville.....	69
Eden.....	46, 61, 64, 65
Mt. Auburn concretionary.....	69
Mount Hope.....	66
origin of.....	42
structural features.....	48
testimony of.....	45
Waynesville.....	70
Shandon section.....	123
Shells, marine.....	42
Siliceous cement.....	40
Sinks, how formed.....	72
Sinks, illustrations of.....	73
Silt-filled valleys.....	154
Silt soils.....	187
Silt, surface.....	173
Slates.....	37
Slopes of flood plains.....	93
Slumping defined.....	77
Soils, alluvial.....	187
classified.....	184
colluvial.....	185
composition of.....	183
loess.....	186



	Page.
Soils of the area.....	185
on boulder clay.....	187
residual.....	186
silt.....	187
surface and subsoil.....	183
Solid rock defined.....	36
Solution.....	73
Source of sand of the Ohio and Miami.....	39
Source of water in Richmond and Maysville groups.....	174
South Lebanon.....	30, 34
Stone, building.....	177
character of.....	177
uses of.....	178
Strata succession.....	49
Stratum defined.....	51
Stream planation.....	90
Streams.....	163
Structural features in sedimentary rocks.....	47
Structure of bed rock.....	55
Subaerial rocks.....	47
Subsequent streams.....	84
Subsoil.....	183
Subsoil, functions of.....	184
Succession of strata.....	49
Surface silt.....	173
brick.....	179
origin of.....	141
sand beneath.....	182
Surface soil.....	183
Surface till.....	173
System defined.....	52
Talus.....	74
Terminal deposits.....	82
moraine defined.....	108
moraine, how formed.....	109
moraine, topography of.....	109
Terrace Park.....	30, 40, 91
Terraces of the Miami, Little Miami, and Ohio.....	93
Thickness of bed rocks.....	56
Till.....	124
plains.....	20, 21
surface.....	173
Todds Fork changes.....	120
Todds Fork, preglacial drainage of.....	114
Topography.....	23
left by Illinoian glacier.....	135
progressive changes in.....	96
Traction.....	79
Transportation.....	77, 79
in solution.....	77
in suspension.....	78

	Page.
Transportation modified by velocity.....	79
on the bottom.....	79
Trenton age.....	60
Trenton limestone as a source of water.....	174
Trough, Norwood.....	32
New Haven.....	32
of Licking River.....	29
of Little Miami River.....	29
of Miami River.....	30
of Ohio River.....	24
Union Village.....	34
Turkey Bottoms.....	25, 30
Unconcentrated wash.....	77
Unconformity defined.....	52
Underground waters.....	169
Undertow.....	38
Union Village trough.....	34
Uplands.....	24
Uplift.....	112
Uses of stone.....	178
Utica shale.....	61
Valley drift, topography of.....	127
Valley floor of Miami River.....	31
Valley floor of the Ohio River.....	26
Valley, Little Miami.....	105
Miami.....	105
Mill Creek.....	32, 65, 105, 114
Valley train, Little Miami.....	150
Mill Creek.....	151
Ohio.....	153
Valley trains.....	110
Valleys, branching of.....	87
consequent.....	84
cross sections of.....	88
dendritic.....	88
down cutting of.....	85
headward growth of.....	86
making of.....	84
silt-filled.....	154
subsequent.....	84
widening of.....	85
Variations of bed rocks.....	56
Velocity, effect of on transporting power.....	79
Vertical accretion.....	92
Water and land, distribution of.....	44
Water-bearing formations.....	172
Water from the Eden shale.....	174

	Page.
Water from the Maysville and Richmond groups.....	174
in the St. Peters sandstone.....	175
in the Trenton limestone.....	174
power.....	165
resources.....	163
supply from streams.....	164
supply from the Ohio.....	164
table.....	170
Waynesville shale.....	70
Weathering of rocks.....	71
Wells.....	172
West Cincinnati quadrangle.....	19
West Fork of Mill Creek.....	33
White clay.....	140
Whitewater.....	30, 33, 80
Whitewater, Dry Fork.....	35
Whitewater formation.....	70, 71
Widening of valleys.....	85
Wind, work of.....	161
Wisconsin drift, character of.....	146
Wisconsin drift, thickness of.....	145
Wisconsin drift, topography of.....	145
glacial outwash.....	148
glacial stage.....	143
glacial stage deposits.....	181
glacier, behavior of.....	148
glacier, limit of.....	143
outwash sand.....	183

TOPOGRAPHIC MAP OF CINCINNATI AND VICINITY.

BULLETIN 19, FOURTH SERIES, GEOLOGICAL SURVEY OF OHIO.











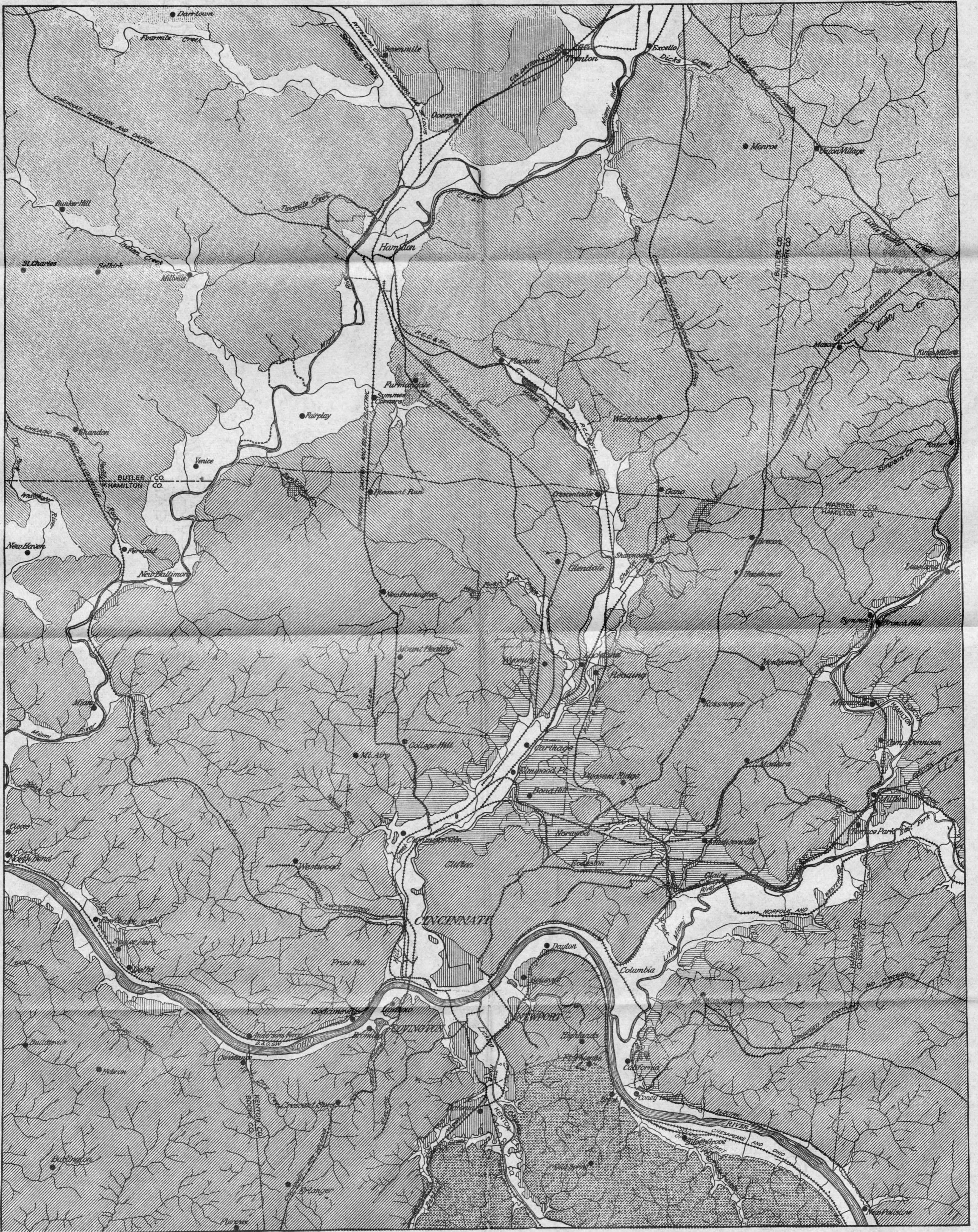

0 1 2 3 4 5  
SCALE - MILES  
CONTOUR INTERVAL - 100 FEET

The larger and more detailed maps of the United States Geological Survey (described in the footnote, p. 20) may be purchased at the Davis L. James Bookstore, Cincinnati.

PHYSIOGRAPHIC MAP OF CINCINNATI AND VICINITY.

BULLETIN 19, FOURTH SERIES, GEOLOGICAL SURVEY OF OHIO.

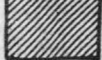

- |                                                                                                     |                                                                                                                                    |                                                                                                                                                      |                                                                                                                          |                                                                                                                                        |                                                                                                                       |                                                                                                                                               |                                                                                                                                                                                  |                                                                                                                                                                                           |
|-----------------------------------------------------------------------------------------------------|------------------------------------------------------------------------------------------------------------------------------------|------------------------------------------------------------------------------------------------------------------------------------------------------|--------------------------------------------------------------------------------------------------------------------------|----------------------------------------------------------------------------------------------------------------------------------------|-----------------------------------------------------------------------------------------------------------------------|-----------------------------------------------------------------------------------------------------------------------------------------------|----------------------------------------------------------------------------------------------------------------------------------------------------------------------------------|-------------------------------------------------------------------------------------------------------------------------------------------------------------------------------------------|
|  Recent Alluvium |  Glacial (with some post glacial) lake deposits |  Interbedded and undifferentiated till, outwash and lake deposits |  Kames of the Wisconsin Glacial Stage |  Outwash (terraces) of the Wisconsin Glacial Stage |  Till of Wisconsin Glacial Stage |  Interbedded till and outwash of Illinoian Glacial Stage |  Illinoian till thinly covering uplands, in most places overlain by loess or its equivalent |  Unglacial but generally covered with equivalent of loess containing some small stones near its base |
| Post Glacial                                                                                        | Wisconsin Glacial Stage                                                                                                            |                                                                                                                                                      |                                                                                                                          | Illinoian Glacial Stage                                                                                                                |                                                                                                                       |                                                                                                                                               |                                                                                                                                                                                  |                                                                                                                                                                                           |

SCALE - MILES  
0 1 2 3 4 5  
CONTOUR INTERVAL - 100 FEET